

PILOT'S OPERATING HANDBOOK

PIPER CHEROKEE LANCE

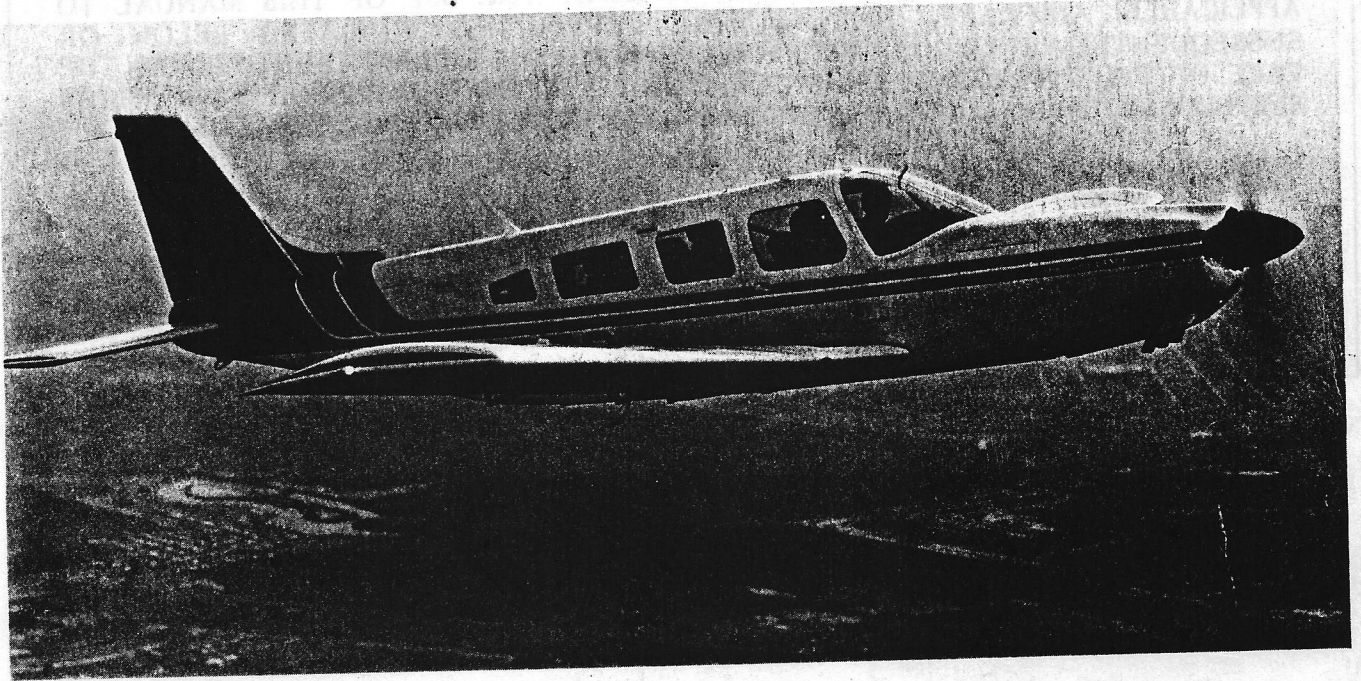

FAA APPROVED IN NORMAL CATEGORY BASED ON CAR 3 AND FAR PART 21, SUBPART J. THIS DOCUMENT INCLUDES THE MATERIAL REQUIRED TO BE FURNISHED TO THE PILOT BY CAR 3 AND FAR PART 21, SUBPART J AND MUST BE CARRIED IN THE AIRPLANE AT ALL TIMES.

AIRPLANE SERIAL NO. 32R-7680022

AIRPLANE REGISTRATION NO. N4505X

PA-32R-300
REPORT: VB-750

FAA APPROVED BY: Ward Evans

WARD EVANS
D.O.A. NO. SO-1
PIPER AIRCRAFT CORPORATION
VERO BEACH, FLORIDA

DATE OF APPROVAL: AUGUST 1, 1975



PILOTS
OPERATING
HANDBOOK

WARNING

EXTREME CARE MUST BE EXERCISED TO LIMIT THE USE OF THIS MANUAL TO APPLICABLE AIRCRAFT. THIS MANUAL REVISED AS INDICATED BELOW OR SUBSEQUENTLY REVISED IS VALID FOR USE WITH THE AIRPLANE IDENTIFIED ON THE FACE OF THE TITLE PAGE WHEN OFFICIALLY APPROVED. SUBSEQUENT REVISIONS SUPPLIED BY PIPER AIRCRAFT CORPORATION MUST BE PROPERLY INSERTED.

MODEL PA-32R-300, CHEROKEE LANCE

PILOT'S OPERATING HANDBOOK, REPORT: VB-750 REVISION _____ 1 _____

PIPER AIRCRAFT CORPORATION
APPROVAL SIGNATURE AND STAMP *M. Keller* _____



Published by
PUBLICATIONS DEPARTMENT
Piper Aircraft Corporation
Issued: August 1, 1975

APPLICABILITY

The aircraft serial number eligibility bracket for application of this handbook is 32R-7680001 through 32R-7680525. The specific application of this handbook is limited to the Piper PA-32R-300 model airplane designated by serial number and registration number on the face of the title page of this handbook.

This handbook cannot be used for operational purposes unless kept in a current status.

REVISIONS

The information compiled in the Pilot's Operating Handbook will be kept current by revisions distributed to the airplane owners.

Revision material will consist of information necessary to update the text of the present handbook and/or to add information to cover added airplane equipment.

I. Revisions

Revisions will be distributed whenever necessary as complete page replacements or additions and shall be inserted into the handbook in accordance with the instructions given below:

1. Revision pages will replace only pages with the same page number.
2. Insert all additional pages in proper numerical order within each section.
3. Page numbers followed by a small letter shall be inserted in direct sequence with the same common numbered page.

II. Identification of Revised Material

Revised text and illustrations shall be indicated by a black vertical line along the outside margin of the page, opposite revised, added or deleted material. A line along the outside margin of the page opposite the page number will indicate that an entire page was added.

Black lines will indicate only current revisions with changes and additions to or deletions of existing text and illustrations. Changes in capitalization, spelling, punctuation or the physical location of material on a page will not be identified by symbols.

ORIGINAL PAGES ISSUED

The original pages issued for this handbook prior to revision are given below:

Title, ii through v, 1-1 through 1-14, 2-1 through 2-10, 3-1 through 3-14, 4-1 through 4-18, 5-1 through 5-28, 6-1 through 6-52, 7-1 through 7-28, 8-1 through 8-16, 9-1 through 9-6, 10-1 through 10-2.

PILOT'S OPERATING HANDBOOK LOG OF REVISIONS

Current Revisions to the PA-32R-300 Cherokee Lance Pilot's Operating Handbook, REPORT: VB-750 issued August 1, 1975.

Revision Number and Code	Revised Pages	Description of Revision	FAA Approval Signature and Date
Rev. 1 - 761 616 (PR750915)	1-7	Revised definition of Demonstrated Crosswind Velocity.	
	2-8	Revised emergency gear lever placard.	
	4-5	Revised Short Field Takeoff procedure; revised gear up Best Angle of Climb Speed designation.	
	6.1	Revised general info. - Paragraph 6.1.	
	6-36	Added item 103.	
	6-39	Added items 147, 149 and 151.	
	6-41	Revised items 163 and 165.	
	6-43	Added items 198 and 202; relocated items 205, 207 and 209 to pg. 6-44.	
	6-44	Added items 205, 207 and 209 from pg. 6-43; revised items 211 and 213.	
	6-45	Added item 226; revised item 229.	
	9-i	Added Supplements 2, 3, 4 and 5.	
	9-7, 9-8	Issued Pages (Added Supplement 2 - AutoFlite II)	
	9-9, 9-10, 9-11, 9-12	Issued Pages (Added Supplement 3 - AutoControl IIIB)	
	9-13, 9-14, 9-15, 9-16, 9-17, 9-18	Issued Pages (Added Supplement 4 - AltiMatic IIIC)	
9-19, 9-20	Issued Pages (Added Supplement 5 - Piper Electric Pitch Trim)		
			<i>Ward Evans</i> ✓ Ward Evans Sept. 15, 1975
Rev. 2 - 761 616 (PR760105)	1-3	Added Engine Model No. and Ser. No. effectivity.	
	2-2	Added Engine Model No. and Ser. No. effectivity.	
	4-13	Added footnote.	
	6-19	Added Ser. No. to item 5; added item 6.	
	6-37	Removed Piper Dwg. No. from item 123.	
	6-44	Added items 204 and 206; relocated items 219 and 221 to page 6-45.	
	6-45	Added items 219 and 221 from page 6-44; relocated items 229 and 231 to page 6-46.	
	6-46	Added items 229 and 231 from page 6-45; revised item 229.	
	7-3	Added Engine Model No. and Ser. No. effectivity.	
	7-6	Revised Landing Gear info.	
	7-7	Added WARNING; revised Landing Gear info.	
7-27	Revised ELT pilot's remote switch info.		
8-5	Revised 8.7 (a), items (1), (2), and (3).		
			<i>Ward Evans</i> ✓ Ward Evans Jan. 5, 1976

PILOT'S OPERATING HANDBOOK LOG OF REVISIONS (cont)

Revision Number and Code	Revised Pages	Description of Revision	FAA Approval Signature and Date
Rev. 5 - 761 616 (PR 790205) (cont)	9-13 thru 9-18 9-19, 9-20	Revised Altimatic IIIG Autopilot info. Revised Electric Pitch Trim info.	<i>Ward Evans</i> ✓ Ward Evans Feb. 5, 1979
Rev. 6 - 761 616 (PR 840713)	v 1-3 1-6 1-7 2-1 2-2 3-i 3-1 4-i 4-1 4-3, 4-4, 4-5 4-7 4-8 4-11 4-12 5-1 5-3, 5-4, 5-5, 5-6 6-1 6-3 6-6 6-7 6-9 6-10 6-17 6-19 7-3 7-17 7-25 8-3 8-4 8-11 10-i 10-1 10-2	Revised Table of Contents. Revised para. 1.3 and para. 1.7. Revised para. 1.19(b). Revised para. 1.19(e). Revised para. 2.1. Revised para. 2.7. Revised Table of Contents. Revised para. 3.1. Revised Table of Contents. Revised para. 4.1 and para. 4.3. Revised para. 4.5. Revised para. 4.7 and para. 4.9. Revised para. 4.9 info. and para. 4.11. Revised para. 4.17 and para. 4.19. Revised para. 4.21. Revised para. 5.1 and para. 5.3. Revised para. 5.5. Revised para. 6.1. Revised para. 6.3. Revised para. 6.5. Revised Fig. 6-5. Revised Fig. 6-7. Revised Fig. 6-7 (cont). Revised para. 6.9. Revised items 5 and 6. Revised para. 7.5. Revised para. 7.17 info. Revised para. 7.33. Revised para. 8.3. Revised para. 8.5. Revised para. 8.21(b). Revised Table of Contents. Revised Title; revised para. 10.1 and para. 10.3. Revised Title.	
			<i>Ward Evans</i> ✓ Ward Evans July 13, 1984

PILOT'S OPERATING HANDBOOK LOG OF REVISIONS (cont)

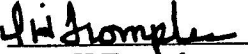
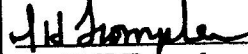
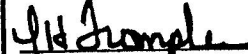
Revision Number and Code	Revised Pages	Description of Revision	FAA Approval Signature and Date
Rev. 7 - 761 616 (PR851127)	3-i 3-3 3-4 3-5 3-8 ✓3-9, ✓3-10	Revised Table of Contents. Revised para. 3.3. Relocated info from 3-3. Relocated info from 3-4. Revised para. 3.11. Revised para. 3.13.	 D.H. Trompler Nov. 27, 1985
Rev. 8 - 761 616 (PR870131)	2-8 ✓3-3 ✓3-4 3-7 ✓3-9, ✓3-10 ✓3-12 4-5 4-12 4-13 4-17 7-5 7-6 7-7 7-8 7-9 7-10 7-20	Revised para. 2.25. Revised Engine Power Loss During Takeoff Checklist and Power Off Landing Checklist Revised Emergency Landing Gear Extension check list Revised para. 3.9. Revised para. 3.13. Revised para. 3.23. Revised para. 3.25. Added Note Revised Short Field, Obstacle Clearance check list Revised para. 4.21. Added Note to para. 4.25. Revised footnote. Revised para. 4.39. Added new info. Revised fig. 7.1. Revised fig. 7.3. Revised para. 7.11. Relocated Warning from page 7-7. Relocated Warning to page 7-6. Revised para. 7.11. Added new info. Revised fig. 7.5. Revised fig. 7.7. Revised fig. 7.9. Revised fig. 7.21.	 D.H. Trompler May 14, 1987 Date
Rev. 9 - 761 616 (PR900425)	iv-c 8-1 8-3 8-11	Added Revision 9 to Log of Revisions. Revised para. 8.1. Revised para. 8.3. Revised para. 8.19.	 D.H. Trompler May 3, 1990 Date

PILOT'S OPERATING HANDBOOK LOG OF REVISIONS (cont)

Revision Number and Code	Revised Pages	Description of Revision	FAA Approval Signature and Date
Rev. 10 - 761 616 (PR900921)	3-3 3-4 3-9 3-12 8-4	Editorial correction. Revised Emergency Landing Gear Extension check list. Revised para. 3.13. Revised para. 3.27. Revised para. 8.5.	 D. H. Trompler ✓ <u>October 18, 1990</u> Date

TABLE OF CONTENTS

SECTION 1	GENERAL
SECTION 2	LIMITATIONS
SECTION 3	EMERGENCY PROCEDURES
SECTION 4	NORMAL PROCEDURES
SECTION 5	PERFORMANCE
SECTION 6	WEIGHT AND BALANCE
SECTION 7	DESCRIPTION AND OPERATION OF THE AIRPLANE AND ITS SYSTEMS
SECTION 8	AIRPLANE HANDLING, SERVICING AND MAINTENANCE
SECTION 9	SUPPLEMENTS
SECTION 10	OPERATING TIPS

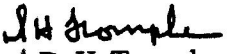
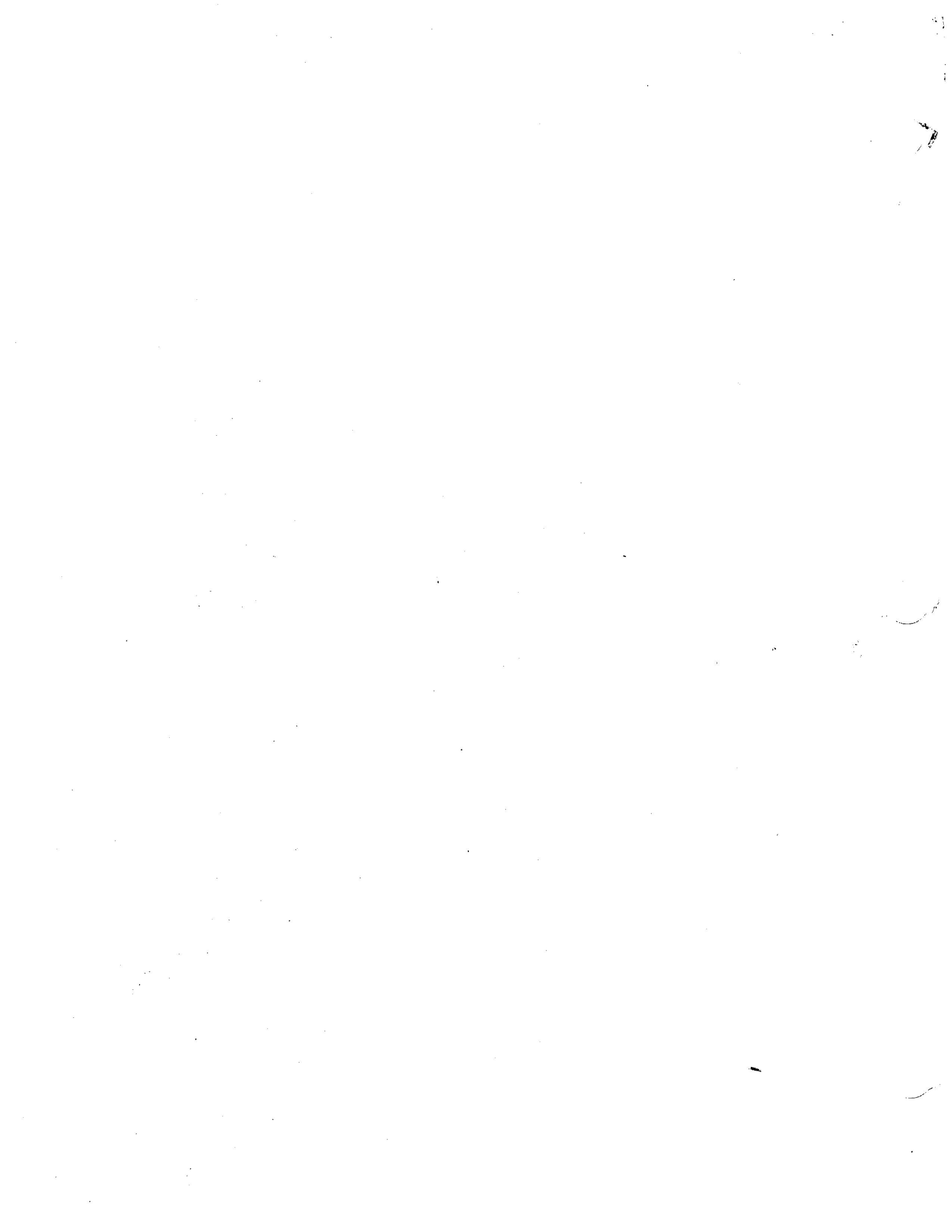

TABLE OF CONTENTS

SECTION 1

GENERAL

Paragraph No.		Page No.
1.1	Introduction	1-1
1.3	Engines	1-3
1.5	Propellers	1-3
1.7	Fuel	1-3
1.9	Oil	1-3
1.11	Maximum Weights	1-4
1.13	Standard Airplane Weights	1-4
1.15	Baggage Space	1-4
1.17	Specific Loadings	1-4
1.19	Symbols, Abbreviations and Terminology	1-5
1.21	Conversion Factors	1-11

REPORT: VB-750

SECTION 1

GENERAL

1.1 INTRODUCTION

This Pilot's Operating Handbook is designed for maximum utilization as an operating guide for the pilot. It includes the material required to be furnished to the pilot by C.A.R. 3 and FAR Part 21 Subpart J. It also contains supplemental data supplied by the airplane manufacturer.

This handbook is not designed as a substitute for adequate and competent flight instruction, knowledge of current airworthiness directives, applicable federal air regulations or advisory circulars. It is not intended to be a guide for basic flight instruction or a training manual and should not be used for operational purposes unless kept in a current status.

Assurance that the airplane is in an airworthy condition is the responsibility of the owner. The pilot in command is responsible for determining that the airplane is safe for flight. The pilot is also responsible for remaining within the operating limitations as outlined by instrument markings, placards, and this handbook.

Although the arrangement of this handbook is intended to increase its in-flight capabilities, it should not be used solely as an occasional operating reference. The pilot should study the entire handbook to familiarize himself with the limitations, performance, procedures and operational handling characteristics of the airplane before flight.

The handbook has been divided into numbered (arabic) sections each provided with a "finger-tip" tab divider for quick reference. The limitations and emergency procedures have been placed ahead of the normal procedures, performance and other sections to provide easier access to information that may be required in flight. The "Emergency Procedures" Section has been furnished with a red tab divider to present an instant reference to the section. Provisions for expansion of the handbook have been made by the deliberate omission of certain paragraph numbers, figure numbers, item numbers and pages noted as being intentionally left blank.

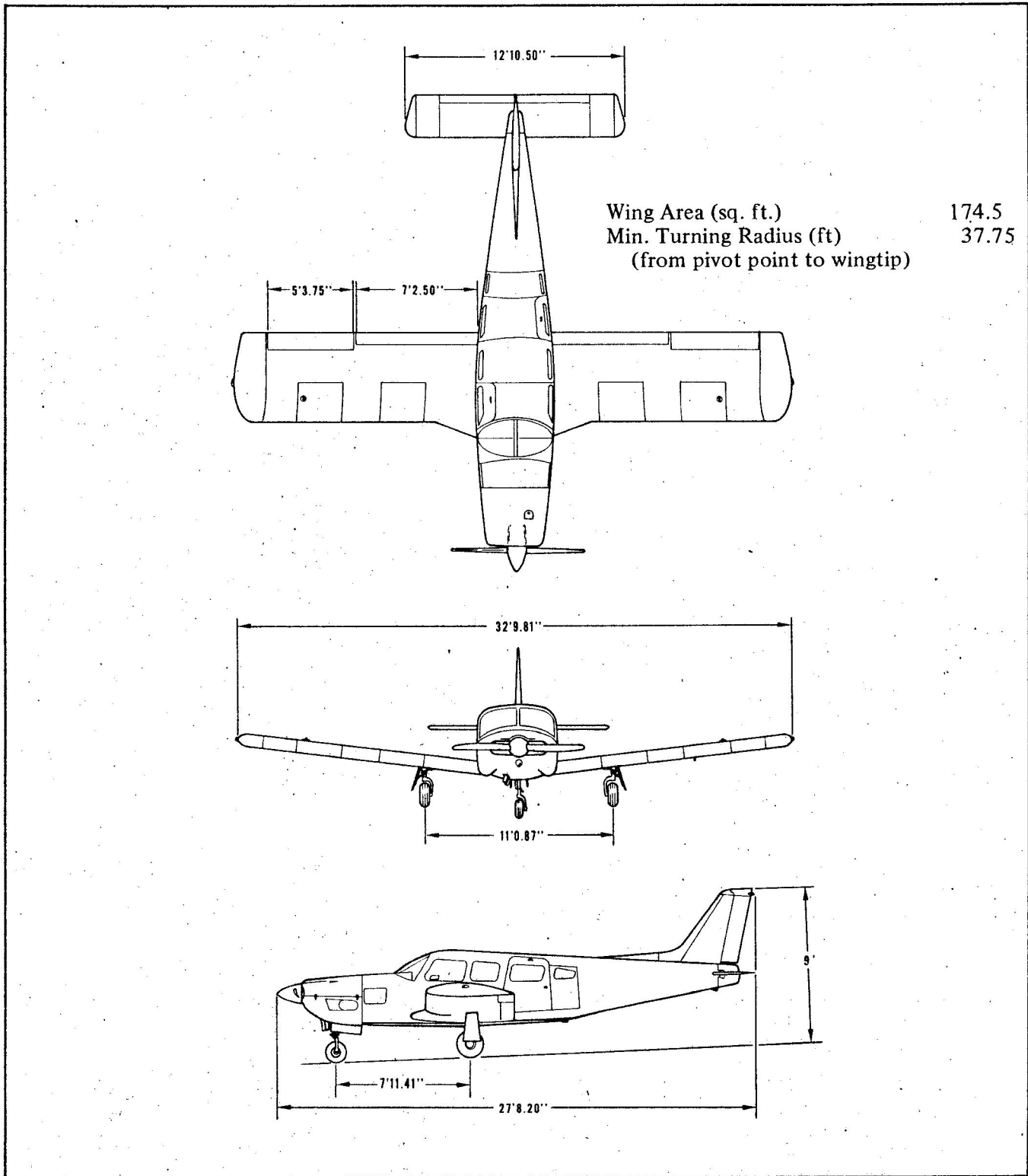

THREE VIEW

Figure 1-1

1.3 ENGINES

(a) Number of Engines		1
(b) Engine Manufacturer		Lycoming
(c) Engine Model Number	(Serial Nos. 32R-7680001 through 32R-7680140)	IO-540-K1A5D
	(Serial Nos. 32R-7680141 through 32R-7680525)	IO-540-K1G5D
(d) Rated Horsepower		300
(e) Rated Speed (rpm)		2700
(f) Bore (inches)		5.125
(g) Stroke (inches)		4.375
(h) Displacement (cubic inches)		541.5
(i) Compression Ratio		8.7:1
(j) Engine Type		Six Cylinder, Direct Drive, Horizontally Opposed, Air Cooled

1.5 PROPELLERS

(a) Number of Propellers		1
(b) Propeller Manufacturer		Hartzell
(c) Blade Model		F8475D-4
(d) Number of Blades		2
(e) Hub Model		HC-C2YK-1()F
(f) Propeller Diameter (inches)		80
(1) Maximum		78.5
(2) Minimum		
(g) Propeller Type		Constant Speed, Hydraulically Actuated

1.7 FUEL

AVGAS ONLY

(a) Fuel Capacity (U.S. gal) (total)		98
(b) Usable Fuel (U.S. gal) (total)		94
(c) Fuel Grade, Aviation (min. octane)		100/130 - Green

1.9 OIL

(a) Oil Capacity (U.S. quarts)		12
(b) Oil Specification		Refer to latest issue of Lycoming Service Instruction 1014.
(c) Oil Viscosity per Average Ambient Temp. for Starting		
		SINGLE MULTI
(1) Above 60°F		50 40 or 50
(2) 30°F to 90°F		40 40
(3) 0°F to 70°F		30 40 or 20W-30
(4) Below 10°F		20 20W-30

1.11 MAXIMUM WEIGHTS

(a) Maximum Takeoff Weight (lbs)		3600
(b) Maximum Landing Weight (lbs)		3600
	FORWARD	AFT
(c) Maximum Weights in Baggage Compartments	100	100

1.13 STANDARD AIRPLANE WEIGHTS*

(a) Standard Empty Weight (lbs): Weight of a standard airplane including unusable fuel, full operating fluids and full oil.		1956
(b) Maximum Useful Load (lbs): The difference between the Maximum Takeoff Weight and the Standard Empty Weight.		1644

1.15 BAGGAGE SPACE

	FORWARD	AFT
(a) Compartment Volume (cubic feet)	7.0	20.0
(b) Entry Width (inches)	16.0	48.0
(c) Entry Height (inches)	22.0	26.0

1.17 SPECIFIC LOADINGS

(a) Wing Loading (lbs per sq ft)	20.6
(b) Power Loading (lbs per hp)	12.0

*These values are approximate and vary from one aircraft to another. Refer to Figure 6-5 for the Standard Empty Weight value and the Useful Load value to be used for C.G. calculations for the aircraft specified.

1.19 SYMBOLS, ABBREVIATIONS AND TERMINOLOGY

The following definitions are of symbols, abbreviations and terminology used throughout the handbook and those which may be of added operational significance to the pilot.

(a) General Airspeed Terminology and Symbols

CAS	Calibrated Airspeed means the indicated speed of an aircraft, corrected for position and instrument error. Calibrated airspeed is equal to true airspeed in standard atmosphere at sea level.
KCAS	Calibrated Airspeed expressed in "Knots."
GS	Ground Speed is the speed of an airplane relative to the ground.
IAS	Indicated Airspeed is the speed of an aircraft as shown on the airspeed indicator when corrected for instrument error. IAS values published in this handbook assume zero instrument error.
KIAS	Indicated Airspeed expressed in "Knots."
M	Mach Number is the ratio of true airspeed to the speed of sound.
TAS	True Airspeed is the airspeed of an airplane relative to undisturbed air which is the CAS corrected for altitude, temperature and compressability.
V _A	Maneuvering Speed is the maximum speed at which application of full available aerodynamic control will not overstress the airplane.
V _{FE}	Maximum Flap Extended Speed is the highest speed permissible with wing flaps in a prescribed extended position.
V _{LE}	Maximum Landing Gear Extended Speed is the maximum speed at which an aircraft can be safely flown with the landing gear extended.
V _{LO}	Maximum Landing Gear Operating Speed is the maximum speed at which the landing gear can be safely extended or retracted.
V _{NE} /M _{NE}	Never Exceed Speed or Mach Number is the speed limit that may not be exceeded at any time.
V _{NO}	Maximum Structural Cruising Speed is the speed that should not be exceeded except in smooth air and then only with caution.

V_S	Stalling Speed or the minimum steady flight speed at which the airplane is controllable.
V_{SO}	Stalling Speed or the minimum steady flight speed at which the airplane is controllable in the landing configuration.
V_X	Best Angle-of-Climb Speed is the airspeed which delivers the greatest gain of altitude in the shortest possible horizontal distance.
V_Y	Best Rate-of-Climb Speed is the airspeed which delivers the greatest gain in altitude in the shortest possible time.

(b) Meteorological Terminology

ISA	International Standard Atmosphere in which: The air is a dry perfect gas; The temperature at sea level is 15° Celsius (59° Fahrenheit); The pressure at sea level is 29.92 inches hg. (1013.2 mb); The temperature gradient from sea level to the altitude at which the temperature is -56.5° C (-69.7°F) is -0.00198°C (-0.003564°F) per foot and zero above that altitude.
OAT	Outside Air Temperature is the free air static temperature, obtained either from inflight temperature indications or ground meteorological sources, adjusted for instrument error and compressibility effects.
Indicated Pressure Altitude	The number actually read from an altimeter when the barometric subscale has been set to 29.92 inches of mercury (1013.2 millibars).
Pressure Altitude	Altitude measured from standard sea-level pressure (29.92 in. Hg) by a pressure or barometric altimeter. It is the indicated pressure altitude corrected for position and instrument error. In this handbook, altimeter instrument errors are assumed to be zero.
Station Pressure	Actual atmospheric pressure at field elevation.
Wind	The wind velocities recorded as variables on the charts of this handbook are to be understood as the headwind or tailwind components of the reported winds.

(c) Power Terminology (Specific)

Takeoff Power	Maximum Rated Power (300 HP @ 2700 RPM)
Maximum Continuous Power	Maximum Rated Power (300 HP @ 2700 RPM)
Maximum Climb Power	Maximum Rated Power (300 HP @ 2700 RPM)
Maximum Cruise Power	Maximum Rated Power (300 HP @ 2700 RPM)
Flight Idle Power	Throttle Closed
Ground Idle Power	Throttle Closed

(d) Engine Instruments

EGT Gauge	Exhaust Gas Temperature Gauge
-----------	-------------------------------

(e) Airplane Performance and Flight Planning Terminology

Climb Gradient	The demonstrated ratio of the change in height during a portion of a climb, to the horizontal distance traversed in the same time interval.
Demonstrated Crosswind Velocity	The demonstrated crosswind velocity is the velocity of the crosswind component for which adequate control of the airplane during takeoff and landing was actually demonstrated during certification tests.
Accelerate-Stop Distance	The distance required to accelerate an airplane to a specified speed and, assuming failure of an engine at the instant that speed is attained, to bring the airplane to a stop.
Route Segment	A part of a route. Each end of that part is identified by: (1) a geographical location; or (2) a point at which a definite radio fix can be established.

(f) Weight and Balance Terminology

Reference Datum	An imaginary vertical plane from which all horizontal distances are measured for balance purposes.
Station	A location along the airplane fuselage usually given in terms of distance from the reference datum.
Arm	The horizontal distance from the reference datum to the center of gravity (C.G.) of an item.
Moment	The product of the weight of an item multiplied by its arm. (Moment divided by a constant is used to simplify balance calculations by reducing the number of digits.)
Center of Gravity (C.G.)	The point at which an airplane would balance if suspended. Its distance from the reference datum is found by dividing the total moment by the total weight of the airplane.
C.G. Arm	The arm obtained by adding the airplane's individual moments and dividing the sum by the total weight.
C.G. Limits	The extreme center of gravity locations within which the airplane must be operated at a given weight.
Usable Fuel	Fuel available for flight planning.
Unusable Fuel	Fuel remaining after a runout test has been completed in accordance with governmental regulations.
Standard Empty Weight	Weight of a standard airplane including unusable fuel, full operating fluids and full oil.
Basic Empty Weight	Standard empty weight plus optional equipment.
Payload	Weight of occupants, cargo and baggage.
Useful Load	Difference between takeoff weight, or ramp weight if applicable, and basic empty weight.
Maximum Ramp Weight	Maximum weight approved for ground maneuver. (It includes weight of start, taxi and run up fuel.)
Maximum Takeoff Weight	Maximum weight approved for the start of the takeoff run.
Maximum Landing Weight	Maximum weight approved for the landing touchdown.
Maximum Zero Fuel Weight	Maximum weight exclusive of usable fuel.

THIS PAGE INTENTIONALLY LEFT BLANK

THIS PAGE INTENTIONALLY LEFT BLANK

1.21 CONVERSION FACTORS

<u>MULTIPLY</u>	<u>BY</u>	<u>TO OBTAIN</u>	<u>MULTIPLY</u>	<u>BY</u>	<u>TO OBTAIN</u>			
acres	0.4047	ha	cubic inches (cu. in.)	16.39	cm ³			
	43560	sq. ft.		1.639×10^{-5}	m ³			
	0.0015625	sq. mi.		5.787×10^{-4}	cu. ft.			
atmospheres (atm)	76	cm Hg	cubic meters (m ³)	0.5541	fl. oz.			
	29.92	in. Hg		0.01639	l			
	1.0133	bar		4.329×10^{-3}	U.S. gal.			
	1.033	kg/cm ²		0.01732	U.S. qt.			
	14.70	lb./sq. in.		61024	cu. in.			
	2116	lb./sq. ft.		1.308	cu. yd.			
bars (bar)	0.98692	atm.	35.3147	cu. ft.				
	14.503768	lb./sq. in.	264.2	U.S. gal.				
British Thermal Unit (BTU)	0.2519958	kg-cal	cubic meters per minute (m ³ /min.)	35.3147	cu. ft./min.			
centimeters (cm)	0.3937	in.	cubic yards (cu. yd.)	27	cu. ft.			
	0.032808	ft.		0.7646	m ³			
centimeters of mercury at 0°C (cm Hg)	0.01316	atm	degrees (arc)	0.01745	radians			
	0.3937	in. Hg		degrees per second (deg./sec.)	0.01745	radians/sec.		
	0.1934	lb./sq. in.			drams, fluid (dr. fl.)	0.125	fl. oz.	
	27.85	lb./sq. ft.				drams, avdp. (dr. avdp.)	0.0625	oz. avdp.
	135.95	kg/m ²					feet (ft.)	30.48
centimeters per second (cm/sec.)	0.032808	ft./sec.	0.3048		m			
	1.9685	ft./min.	12	in.				
	0.02237	mph	0.33333	yd.				
cubic centimeters (cm ³)	0.03381	fl. oz.	0.0606061	rod				
	0.06102	cu. in.	1.894×10^{-4}	mi.				
	3.531×10^{-5}	cu. ft.	1.645×10^{-4}	NM				
	0.001	l	feet per minute (ft./min.)	0.01136	mph			
	2.642×10^{-4}	U.S. gal.		0.01829	km/hr.			
cubic feet (cu.ft.)	28317	cm ³		0.508	cm/sec.			
	0.028317	m ³		0.00508	m/sec.			
	1728	cu. in.		cubic feet per minute (cu. ft./min.)	0.472	l/sec.		
	0.037037	cu. yd.	0.028317		m ³ /min.			
	7.481	U.S. gal.	cubic feet per minute (cu. ft./min.)		0.472	l/sec.		
28.32	l	0.028317			m ³ /min.			

SECTION 1
GENERAL

PIPER AIRCRAFT CORPORATION
PA-32R-300, CHEROKEE LANCE

<u>MULTIPLY</u>	<u>BY</u>	<u>TO OBTAIN</u>	<u>MULTIPLY</u>	<u>BY</u>	<u>TO OBTAIN</u>
feet per second (ft./sec.)	0.6818 1.097 30.48 0.5921	mph km/hr. cm/sec. kts.	hectares (ha)	2.471 107639 10000	acres sq. ft. m ²
foot-pounds (ft.-lb.)	0.138255 3.24 x 10 ⁻⁴	m-kg kg-cal	horsepower (hp)	33000 550 76.04 1.014	ft.-lb./min. ft.-lb./sec. m-kg/sec. metric hp
foot-pounds per minute (ft.-lb./min.)	3.030 x 10 ⁻⁵	hp	horsepower, metric	75 0.9863	m-kg/sec. hp
foot-pounds per second (ft.-lb./sec.)	1.818 x 10 ⁻⁵	hp	inches (in.)	25.40 2.540 0.0254 0.08333 0.027777	mm cm m ft. yd.
gallons, Imperial (Imperial gal.)	277.4 1.201 4.546	cu. in. U.S. gal. 1	inches of mercury at 0°C (in. Hg)	0.033421 0.4912 70.73 345.3 2.540 25.40	atm lb./sq. in. lb./sq. ft. kg/m ² cm Hg mm Hg
gallons, U.S. dry (U.S. gal. dry)	268.8 1.556 x 10 ⁻¹ 1.164 4.405	cu. in. cu. ft. U.S. gal. 1	inch-pounds (in.-lb.)	0.011521	m-kg
gallons, U.S. liquid (U.S. gal.)	231 0.1337 4.951 x 10 ⁻³ 3785.4 3.785 x 10 ⁻³ 3.785 0.83268 128	cu. in. cu. ft. cu. yd. cm ³ m ³ 1 Imperial gal. fl. oz.	kilograms (kg)	2.204622 35.27 1000	lb. oz. avdp. g
gallons per acre (gal./acre)	9.353	1/ha	kilogram-calories (kg-cal)	3.9683 3087 426.9	BTU ft.-lb. m-kg
grams (g)	0.001 0.3527 2.205 x 10 ⁻³	kg oz. avdp. lb.	kilograms per cubic meter (kg/m ³)	0.06243 0.001	lb./cu. ft. g/cm ³
grams per centimeter (g/cm)	0.1 6.721 x 10 ⁻² 5.601 x 10 ⁻³	kg/m lb./ft. lb./in.	kilograms per hectare (kg/ha)	0.892	lb./acre
grams per cubic centimeter (g/cm ³)	1000 0.03613 62.43	kg/m ³ lb./cu. in. lb./cu. ft.	kilograms per square centimeter (kg/cm ²)	0.9678 28.96 14.22 2048	atm in. Hg lb./sq. in. lb./sq. ft.

<u>MULTIPLY</u>	<u>BY</u>	<u>TO OBTAIN</u>	<u>MULTIPLY</u>	<u>BY</u>	<u>TO OBTAIN</u>
kilograms per square meter (kg/m ²)	2.896 x 10 ⁻³ 1.422 x 10 ⁻³ 0.2048	in. Hg lb./sq. in. lb./sq. ft.	meters per minute (m/min.)	0.06	km/hr.
kilometers (km)	1 x 10 ⁻⁵ 3280.8 0.6214 0.53996	cm ft. mi. NM	meters per second (m/sec.)	3.280840 196.8504 2.237 3.6	ft./sec. ft./min. mph km/hr.
kilometers per hour (km/hr.)	0.9113 58.68 0.53996 0.6214 0.27778 16.67	ft./sec. ft./min. kt mph m/sec. m/min.	microns	3.937 x 10 ⁻⁵	in.
knots (kt)	1 1.689 1.1516 1.852 51.48	nautical mph ft./sec. statute mph km/hr. m/sec.	miles, statute (mi.)	5280 1.6093 1609.3 0.8684	ft. km m NM
liters (l)	1000 61.02 0.03531 33.814 0.264172 0.2200 1.05669	cm ³ cu. in. cu. ft. fl. oz. U.S. gal. Imperial gal. qt.	miles per hour (mph)	44.7041 4.470 x 10 ⁻¹ 1.467 88 1.6093 0.8684	cm/sec. m/sec. ft./sec. ft./min. km/hr. kt
liters per hectare (l/ha)	13.69 0.107	fl. oz./acre. gal./acre	miles per hour square (m/hr. sq.)	2.151	ft./sec. sq.
liters per second (l/sec.)	2.12	cu. ft./min.	millibars	2.953 x 10 ⁻²	in. Hg
meters (m)	39.37 3.280840 1.0936 0.198838 6.214 x 10 ⁻⁴ 5.3996 x 10 ⁻⁴	in. ft. yd. rod mi. NM	millimeters (mm)	0.03937	in.
meter-kilogram (m-kg)	7.23301 86.798	ft.-lb. in.-lb.	millimeters of mercury at 0°C (mm Hg)	0.03937	in. Hg
			nautical miles (NM)	6080 1.1516 1852 1.852	ft. statute mi. m km
			ounces, avdp. (oz. avdp.)	28.35 16	g dr. avdp.
			ounces, fluid (fl. oz.)	8 29.57 1.805 0.0296 0.0078	dr. fl. cm ³ cu. in. l U.S. gal.

SECTION 1
GENERAL

PIPER AIRCRAFT CORPORATION
PA-32R-300, CHEROKEE LANCE

<u>MULTIPLY</u>	<u>BY</u>	<u>TO OBTAIN</u>	<u>MULTIPLY</u>	<u>BY</u>	<u>TO OBTAIN</u>
ounces, fluid per acre (fl. oz./acre)	0.073	l/ha	rod	16.5 5.5 5.029	ft. yd. m
pounds (lb.)	0.453592 453.6 3.108×10^{-2}	kg g slug	slug	32.174	lb.
pounds per acre (lb./acre)	1.121	kg/ha	square centimeters (cm ²)	0.1550 0.001076	sq. in. sq. ft.
pounds per cubic foot (lb./cu. ft.)	16.02	kg/m ³	square feet (sq. ft.)	929 0.092903 144	cm ² m ² sq. in.
pounds per cubic inch (lb./cu. in.)	1728 27.68	lb./cu. ft. g/cm ³	square inches (sq. in.)	0.1111 2.296 x 10 ⁻⁵	sq. yd. acres
pounds per square foot (lb./sq. ft.)	0.1414 4.88243 4.725×10^{-4}	in. Hg kg/m ² atm	square kilometers (km ²)	6.4516 6.944×10^{-3}	cm ² sq. ft.
pounds per square inch (psi or lb./sq. in.)	5.1715 2.036 0.06804 0.0689476 703.1	cm Hg in. Hg atm bar kg/m ²	square meters (m ²)	0.3861	sq. mi.
quart, U.S. (qt.)	0.94635 57.749	l cu. in.	square miles (sq. mi.)	10.76391 1.196 0.0001	sq. ft. sq. yd. ha
radians	57.30 0.1592	deg. (arc) rev.	square rods (sq. rods)	2.590 640	km ² acres
radians per second (radians/sec.)	57.30 0.1592 9.549	deg./sec. rev./sec. rpm	square yards (sq. yd.)	30.25	sq. yd.
revolutions (rev.)	6.283	radians	yards (yd.)	0.8361 9 0.0330579	m ² sq. ft. sq. rods
revolutions per minute (rpm or rev./min.)	0.1047	radians/sec.		0.9144 3 36	m ft. in.
revolutions per second (rev./sec.)	6.283	radians/sec.		0.181818	rod

<u>MULTIPLY</u>	<u>BY</u>	<u>TO OBTAIN</u>
lb/sq in.	2.036 6.805×10^{-2} 7.031×10^{-2}	in. Hg at 0°C atmospheres kg/sq m
radians	57.30	deg (arc)
radians/sec	57.30 15.92×10^{-2} 9.549	deg/sec rev/sec rev/min
revolutions	6.283	radians
rev/min	1.047×10^{-1}	radians/sec
rod	16.5 5.5	ft yd
slug	32.174	lb
sq cm	1.550×10^{-1} 1.076×10^{-3}	sq in. sq ft
sq ft	929.0 144.0 1.111×10^{-1} 2.296×10^{-5}	sq cm sq in. sq yards acres
sq in.	6.452	sq cm
sq kilometers	3.861×10^{-1}	sq miles
sq meters	10.76 1.196	sq ft sq yards
sq miles	2.590 640	sq km acres
sq rods	30.25	sq yd
sq yards	8.361×10^{-1} 9	sq m sq ft
yards	9.144×10^{-1} 3.0 36.0	meters ft in.

THIS PAGE INTENTIONALLY LEFT BLANK

TABLE OF CONTENTS

SECTION 2

LIMITATIONS

Paragraph No.		Page No.
2.1	General	2-1
2.3	Airspeed Limitations	2-1
2.5	Airspeed Indicator Markings	2-2
2.7	Power Plant Limitations	2-2
2.9	Power Plant Instrument Markings	2-3
2.11	Weight Limits	2-3
2.13	Center of Gravity Limits	2-4
2.15	Maneuver Limits	2-4
2.17	Flight Load Factors	2-4
2.19	Types of Operations	2-4
2.21	Fuel Limitations	2-5
2.23	Flight With Rear Cabin Door or Rear Cabin Door and Cargo Door Removed	2-5
2.25	Placards	2-7

SECTION 2
LIMITATIONS

2.1 GENERAL

This section provides the "FAA Approved" operating limitations, instrument markings, color coding and basic placards necessary for the operation of the airplane and its systems.

Limitations associated with those optional systems and equipment which require handbook supplements can be found in Section 9 (Supplements).

2.3 AIRSPEED LIMITATIONS

SPEED	CAS
Never Exceed Speed (V_{NE}) - Do not exceed this speed in any operation.	217 MPH (188 KTS)
Maximum Structural Cruising Speed (V_{NO}) - Do not exceed this speed except in smooth air and then only with caution.	172 MPH (149 KTS)
Design Maneuvering Speed (V_A) - Do not make full or abrupt control movements above this speed.	125 MPH (109 KTS)
Maximum Flaps Extended Speed (V_{FE}) - Do not exceed this speed with the flaps extended.	125 MPH (109 KTS)
Maximum Landing Gear Extension Speed - Do not exceed this speed when extending the landing gear.	150 MPH (130 KTS)
Maximum Landing Gear Retraction Speed - Do not exceed this speed when retracting the landing gear.	125 MPH (109 KTS)
Maximum Landing Gear Extended Speed (V_{LE}) - Do not exceed this speed with the landing gear extended.	150 MPH (130 KTS)

2.5 AIRSPEED INDICATOR MARKINGS

MARKING	CAS
Red Radial Line (Never Exceed)	217 MPH (188 KTS)
Yellow Arc (Caution Range - Smooth Air Only)	172 MPH to 217 MPH (149 KTS to 188 KTS)
Green Arc (Normal Operating Range)	77 MPH to 172 MPH (67 KTS to 149 KTS)
White Arc (Flap Down)	70 MPH to 125 MPH (61 KTS to 109 KTS)

2.7 POWER PLANT LIMITATIONS

(a) Number of Engines	1
(b) Engine Manufacturer	Lycoming
(c) Engine Model No.	(Serial Nos. 32R-7680001 through 32R-7680140) IO-540-K1A5D (Serial Nos. 32R-7680141 through 32R-7680525) IO-540-K1G5D
(d) Engine Operating Limits	
(1) Maximum Horsepower	300
(2) Maximum Rotation Speed (RPM)	2700
(3) Maximum Oil Temperature	245° F
(e) Oil Pressure	
Minimum (red line)	25 PSI
Maximum (red line)	100 PSI
(f) Fuel Pressure	
Minimum (red line)	12 PSI
Maximum (red line)	40 PSI
(g) Fuel Grade (AVGAS ONLY) (minimum octane)	100/130 - Green
(h) Number of Propellers	1
(i) Propeller Manufacturer	Hartzell
(j) Propeller Hub and Blade Model	HC-C2YK-1()F/F8475D-4
(k) Propeller Diameter	
Minimum	78.5 IN.
Maximum	80 IN.
(l) Blade Angle Limits	
Low Pitch Stop	13.5 ± .2°
High Pitch Stop	34° ± 1°

2.9 POWER PLANT INSTRUMENT MARKINGS

(a) Tachometer	
Green Arc (Normal Operating Range)	500 to 2700 RPM
Red Line (Maximum Continuous Power)	2700 RPM
(b) Oil Temperature	
Green Arc (Normal Operating Range)	75° to 245° F
Red Line (Maximum)	245° F
(c) Oil Pressure	
Green Arc (Normal Operating Range)	60 PSI to 90 PSI
Yellow Arc (Caution Range) (Idle)	25 PSI to 60 PSI
Yellow Arc (Caution Range) (Start and Warm Up)	90 PSI to 100 PSI
Red Line (Minimum)	25 PSI
Red Line (Maximum)	100 PSI
(d) Fuel Pressure	
Green Arc (Normal Operating Range)	18 PSI to 40 PSI
Red Line (Minimum)	12 PSI
Red Line (Maximum)	40 PSI
Yellow Arc (Idle Range)	12 PSI to 18 PSI

2.11 WEIGHT LIMITS

(a) Maximum Weight	3600 LBS
(b) Maximum Baggage (100 lbs each compartment)	200 LBS

NOTE

Refer to Section 5 (Performance) for maximum weight as limited by performance.

2.13 CENTER OF GRAVITY LIMITS

Weight Pounds	Forward Limit Inches Aft of Datum	Rearward Limit Inches Aft of Datum
3600	91.4	95.0
2900	80.0	95.0
2400	76.0	95.0

NOTES

Straight line variation between points given.

The datum used is 78.4 inches ahead of the wing leading edge at the intersection of the straight and tapered section.

It is the responsibility of the airplane owner and the pilot to insure that the airplane is properly loaded. See Section 6 (Weight and Balance) for proper loading instructions.

2.15 MANEUVER LIMITS

No acrobatic maneuvers including spins approved.

2.17 FLIGHT LOAD FACTORS

- (a) Positive Load Factor (Maximum) 3.8 G
- (b) Negative Load Factor (Maximum) No inverted maneuvers approved

2.19 TYPES OF OPERATIONS

The airplane is approved for the following operations when equipped in accordance with FAR 91 or FAR 135.

- (a) Day V.F.R.
- (b) Night V.F.R.
- (c) Day I.F.R.
- (d) Night I.F.R.
- (e) Non Icing

2.21 FUEL LIMITATIONS

- | | |
|--|-------------|
| (a) Total Capacity | 98 U.S. GAL |
| (b) Unusable Fuel | 4 U.S. GAL |
| The unusable fuel for this airplane has been determined as 2.0 gallons in each wing in critical flight attitudes (2.0 gallons is the total per side, each side having two interconnected tanks). | |
| (c) Usable Fuel | 94 U.S. GAL |
| The usable fuel in this airplane has been determined as 47.0 gallons in each wing (47.0 gallons is the total per side, each side having two interconnected tanks). | |

2.23 FLIGHT WITH REAR CABIN DOOR OR REAR CABIN DOOR AND CARGO DOOR REMOVED

The following limitations must be observed in the operation of this airplane with the rear cabin door or rear cabin door and cargo door removed:

- (a) The airplane may be flown with the rear cabin door or rear cabin door and cargo door removed. Flight with the front door removed is not approved.
- (b) Maximum speed - 165 MPH (143 KTS)
- (c) No smoking.
- (d) All loose articles must be tied down and stowed.
- (e) Jumper's static lines must be kept free of pilot's controls and control surfaces.
- (f) Operation approved VFR flight conditions only.

THIS PAGE INTENTIONALLY LEFT BLANK

2.25 PLACARDS

In full view of the pilot:

“THIS AIRPLANE MUST BE OPERATED AS A NORMAL CATEGORY AIRPLANE IN COMPLIANCE WITH THE OPERATING LIMITATIONS STATED IN THE FORM OF PLACARDS, MARKINGS AND MANUALS. NO ACROBATIC MANEUVERS, INCLUDING SPINS, APPROVED.”

THIS AIRCRAFT APPROVED FOR V.F.R., I.F.R., DAY AND NIGHT NON-ICING FLIGHT WHEN EQUIPPED IN ACCORDANCE WITH FAR 91 OR FAR 135.

In full view of the pilot, the following takeoff and landing check lists will be installed:

TAKEOFF CHECK LIST

Fuel on Proper Tank
Electric Fuel Pump - On
Engine Gauges - Checked
Alternate Air - Closed
Seat Backs Erect

Mixture - Set
Propeller - Set
Fasten Belts/Harness

Flaps - Set
Trim Tab - Set
Controls - Free
Door - Latched
Air Conditioner - Off

LANDING CHECK LIST

Fuel on Proper Tank
Seat Back Erect
Fasten Belts/Harness

Electric Fuel Pump - On
Mixture - Rich
Propeller - Set

Gear Down (150 MPH Max)
Flaps - Set (125 MPH)
Air Conditioner - Off

The “AIR CONDITIONER OFF” item in the above takeoff and landing check lists is mandatory for air conditioned aircraft only.

On the instrument panel in full view of the pilot:

“ROUGH AIR OR MANEUVERING SPEED 125 MPH”

On the instrument panel in full view of the pilot:

DEMONSTRATED CROSSWIND COMPONENT 20 MPH”

In full view of the pilot: (For operation with the rear door removed)

“FOR FLIGHT WITH THE DOOR REMOVED, SEE THE
LIMITATIONS AND PROCEDURES SECTIONS OF THE
PILOT’S OPERATING HANDBOOK.”

On instrument panel in full view of the pilot:

“GEAR DOWN	150 MPH MAX”
“GEAR UP	125 MPH MAX”
“EXTENDED	150 MPH MAX”

Near emergency gear lever:

“EMERGENCY DOWN”

“OVERRIDE ENGAGED

TO ENGAGE OVERRIDE:
LEVER UP, LATCH DOWN
TO RELEASE OVERRIDE:
LEVER FULL UP & RELEASE”

On gear override latch:

“GEAR OVERRIDE LATCH”

Near gear selector switch:

“GEAR UP	125 MPH MAX”
“DOWN	150 MPH MAX”

Adjacent to upper door latch (front and rear doors):

“ENGAGE LATCH BEFORE FLIGHT”

On the instrument panel in full view of the pilot:

“WARNING – TURN OFF STROBE LIGHTS WHEN TAXIING
IN VICINITY OF OTHER AIRCRAFT, OR DURING FLIGHT
THROUGH CLOUD, FOG OR HAZE.”

In full view of the pilot, in the area of the air conditioner controls when the air conditioner is installed:

“WARNING – AIR CONDITIONER MUST BE OFF TO INSURE NORMAL TAKEOFF CLIMB PERFORMANCE.”

On the inside of forward baggage compartment:

“MAXIMUM BAGGAGE THIS COMPARTMENT 100 LBS. SEE THE LIMITATIONS SECTION OF THE PILOT’S OPERATING HANDBOOK.”

On aft baggage closeout:

“MAXIMUM BAGGAGE THIS COMPARTMENT 100 LBS. NO HEAVY OBJECTS ON HAT SHELF.”

On storm window:

“DO NOT OPEN ABOVE 150 MPH”

Adjacent to fuel tank filler caps:

“FUEL – 100/130 AVIATION GRADE – USABLE CAPACITY 47.0 GAL.”

THIS PAGE INTENTIONALLY LEFT BLANK

TABLE OF CONTENTS
SECTION 3
EMERGENCY PROCEDURES

Paragraph No.		Page No.
3.1	General	3-1
3.3	Emergency Procedures Check List	3-3
	Engine Fire During Start	3-3
	Engine Power Loss During Takeoff	3-3
	Engine Power Loss In Flight	3-3
	Power Off Landing	3-3
	Fire In Flight	3-4
	Loss of Oil Pressure	3-4
	Loss of Fuel Pressure	3-4
	High Oil Temperature	3-4
	Alternator Failure	3-4
	Propeller Overspeed	3-4
	Emergency Landing Gear Extension	3-4
	Spin Recovery	3-4
	Open Door	3-4
3.5	Amplified Emergency Procedures (General)	3-7
3.7	Engine Fire During Start	3-7
3.9	Engine Power Loss During Takeoff	3-7
3.11	Engine Power Loss In Flight	3-8
3.13	Power Off Landing	3-9
3.15	Fire In Flight	3-10
3.17	Loss of Oil Pressure	3-11
3.19	Loss of Fuel Pressure	3-11
3.21	High Oil Temperature	3-11
3.23	Alternator Failure	3-12
3.25	Propeller Overspeed	3-12
3.27	Emergency Landing Gear Extension	3-12
3.29	Spin Recovery	3-13
3.31	Open Door	3-13
3.33	Engine Roughness	3-13

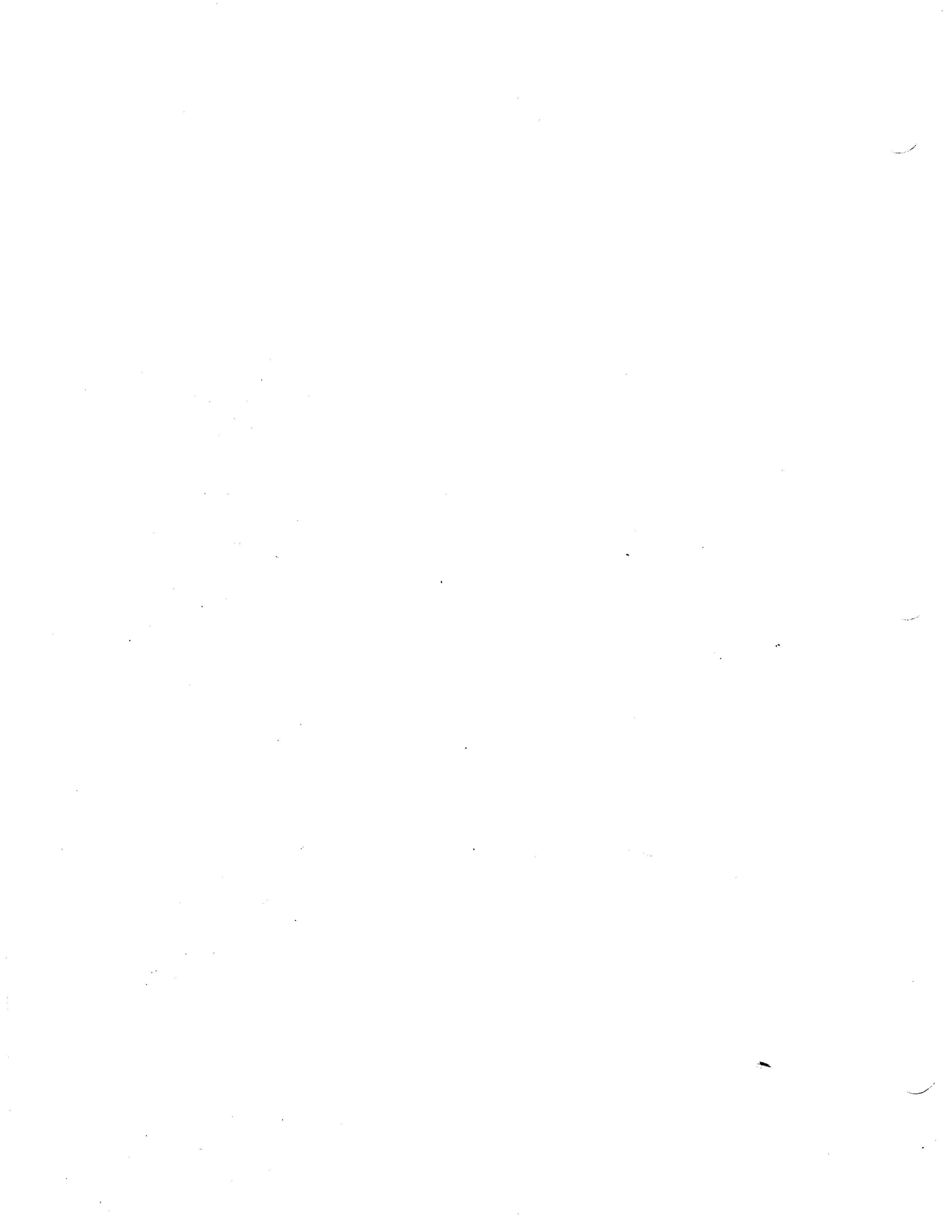

**SECTION 3
EMERGENCY PROCEDURES**

3.1 GENERAL

The recommended procedures for coping with various types of emergencies and critical situations are provided by this section. All of the required (FAA regulations) emergency procedures and those necessary for the operation of the airplane as determined by the operating and design features of the airplane are presented.

Emergency procedures associated with those optional systems and equipment which require handbook supplements are provided in Section 9 (Supplements).

The first portion of this section consists of an abbreviated emergency check list which supplies an action sequence for critical situations with little emphasis on the operation of systems.

The remainder of the section is devoted to amplified emergency procedures containing additional information to provide the pilot with a more complete understanding of the procedures.

These procedures are suggested as a course of action for coping with the particular condition described, but are not a substitute for sound judgment and common sense. Pilots should familiarize themselves with the procedures given in this section and be prepared to take appropriate action should an emergency arise.

Most basic emergency procedures, such as power off landings, are a normal part of pilot training. Although these emergencies are discussed here, this information is not intended to replace such training, but only to provide a source of reference and review, and to provide information on procedures which are not the same for all aircraft. It is suggested that the pilot review standard emergency procedures periodically to remain proficient in them.

THIS PAGE INTENTIONALLY LEFT BLANK

3.3 EMERGENCY PROCEDURES CHECK LIST

ENGINE FIRE DURING START

Starter.....crank engine
Mixtureidle cut-off
Throttleopen
Electric fuel pump.....OFF
Fuel selector.....OFF
Abandon if fire continues

ENGINE POWER LOSS DURING TAKEOFF

If sufficient runway remains for a normal landing, leave gear down and land straight ahead.

If area ahead is rough, or if it is necessary to clear obstructions:

Gear selector switch.....UP
Emergency gear lever (Aircraft equipped with backup gear extender)latched in **OVERRIDE ENGAGED** position

If sufficient altitude has been gained to attempt restart:

Maintain safe airspeed
Fuel selector.....switch to tank containing fuel
Electric fuel pump.....check ON
Mixturecheck RICH
Alternate airOPEN
Emergency gear leveras required

If power is not regained, proceed with power off landing.

ENGINE POWER LOSS IN FLIGHT

Fuel selector.....switch to tank containing fuel
Electric fuel pumpON
MixtureRICH
Alternate airOPEN
Engine gaugescheck for indication of cause of power loss

If no fuel pressure is indicated, check tank selector position to be sure it is on a tank containing fuel.

When power is restored:

Alternate airCLOSED
Electric fuel pump.....OFF

If power is not restored prepare for power off landing.

POWER OFF LANDING

On aircraft equipped with backup gear extender, lock emergency gear lever in **OVERRIDE ENGAGED** position before airspeed drops to 122 mph IAS (106 KIAS) to prevent landing gear from inadvertently free falling.

Trim to 106 mph IAS (92 kts IAS).

Locate suitable field.

Establish spiral pattern. 1000 ft above field at downwind position for normal landing approach.

When field can easily be reached slow to 86 mph IAS (75 kts IAS) for shortest landing.

Touchdowns should normally be made at lowest possible airspeed with full flaps.

GEAR DOWN LANDING

For gear down landing, proceed as follows when committed to landing:

Landing Gear SelectorDOWN
Ignition.....OFF
Master switch.....OFF
Fuel selector.....OFF
Mixtureidle cut-off
Seat belt and harness.....tight

GEAR UP LANDING

For gear up landing, proceed as follows when committed to landing:

Ignition.....OFF
Master switch.....OFF
Fuel selector.....OFF
Mixtureidle cut-off
Seat belt and harness.....tight

FIRE IN FLIGHT

Source of firecheck
Electrical fire (smoke in cabin):
Master switchOFF
Ventsopen
Cabin heatOFF
Land as soon as possible.

Engine fire:
Magneto switchOFF
ThrottleCLOSED
Mixtureidle cut-off
Fuel selectorOFF
Electric fuel pumpcheck OFF
Master switchOFF
Dive to blow out fire (if altitude permits).
Proceed with power off landing.

LOSS OF OIL PRESSURE

Land as soon as possible and investigate cause.
Prepare for power off landing.

LOSS OF FUEL PRESSURE

Electric fuel pumpON
Fuel selectorcheck on full tank

HIGH OIL TEMPERATURE

Land at nearest airport and investigate the problem.
Prepare for power off landing.

ALTERNATOR FAILURE

Verify failure
Reduce electrical load
Alternator circuit breakerscheck
Alt switchOFF (for 1 second),
then on

If no output:
Alt switchOFF

Reduce electrical load and land as soon as practical.

If battery is fully discharged, the gear will have to be lowered using the emergency gear extension procedure. Position lights will not illuminate.

PROPELLER OVERSPEED

Throttleretard
Oil pressurecheck
Prop controlfull DECREASE rpm,
then set if any
control available
Airspeedreduce
Throttleas required to remain
below 2700 rpm

EMERGENCY LANDING GEAR EXTENSION

Prior to emergency extension procedure:

Master switchcheck ON
Circuit breakerscheck
Radio lightsoff (in daytime)
Gear indicator bulbscheck

If landing gear does not check down and locked:

Airspeedbelow 100 mph IAS
(87 kts IAS)

Landing gear selectorDOWN
Emergency gear lever (Aircraft equipped with
backup gear extender)**VERRIDE ENGAGED**
(while fish tailing airplane)

If landing gear still does not check down and locked:

Emergency gear lever**Hold** emergency gear lever
in the **EMERGENCY DOWN**
position, while fish tailing airplane
until gear is down and locked (under
normal conditions will take approx.
10 seconds to be down and locked)

If all electrical power has been lost, the landing gear must be extended using the above procedures. The gear position indicator lights will not illuminate.

SPIN RECOVERY

Throttleidle
Aileronsneutral
Rudderfull opposite to
direction of rotation
Control wheelfull forward
Rudderneutral (when
rotation stops)
Control wheelas required to smoothly
regain level flight altitude

THIS PAGE INTENTIONALLY LEFT BLANK

THIS PAGE INTENTIONALLY LEFT BLANK

3.5 AMPLIFIED EMERGENCY PROCEDURES (GENERAL)

The following paragraphs are presented to supply additional information for the purpose of providing the pilot with a more complete understanding of the recommended course of action and probable cause of an emergency situation.

3.7 ENGINE FIRE DURING START

Engine fires during start are usually the result of overpriming. The first attempt to extinguish the fire is to try to start the engine and draw the excess fuel back into the induction system.

If a fire is present before the engine has started, move the mixture control to idle cut-off, open the throttle and crank the engine. This is an attempt to draw the fire back into the engine.

If the engine has started, continue operating to try to pull the fire into the engine.

In either case (above), if fire continues more than a few seconds, the fire should be extinguished by the best available external means.

The fuel selector valves should be "OFF" and the mixture at idle cut-off if an external fire extinguishing method is to be used.

3.9 ENGINE POWER LOSS DURING TAKEOFF

The proper action to be taken if loss of power occurs during takeoff will depend on the circumstances of the particular situation.

If sufficient runway remains to complete a normal landing, leave the landing gear down and land straight ahead.

If the area ahead is rough, or if it is necessary to clear obstructions, move the gear selector switch to the "UP" position and latch the emergency gear lever in the "OVERRIDE ENGAGED" position.

If sufficient altitude has been gained to attempt a restart, maintain a safe airspeed and switch the fuel selector to another tank containing fuel. Check the electric fuel pump to insure that it is "ON" and that the mixture is "RICH." The alternate air should be "OPEN." Use the emergency gear lever as required.

The landing gear will extend automatically when engine power fails at speeds below approximately 118 MPH IAS (103 KTS IAS). The glide distance with the landing gear extended is roughly halved. If the situation dictates, the landing gear can be retained in the retracted position by latching the lever in the "OVERRIDE ENGAGED" position.

If engine failure was caused by fuel exhaustion, power will not be regained after switching fuel tanks until the empty fuel lines are filled. This may require up to ten seconds.

If power is not regained, proceed with the Power Off Landing procedure (refer to the emergency check list and paragraph 3.13).

3.11 ENGINE POWER LOSS IN FLIGHT

Complete engine power loss is usually caused by fuel flow interruption and power will be restored shortly after fuel flow is restored. If power loss occurs at a low altitude, the first step is to prepare for an emergency landing (refer to paragraph 3.13). An airspeed of at least 100 MPH IAS (87 KTS IAS) should be maintained.

If altitude permits, switch the fuel selector to another tank containing fuel and turn the electric fuel pump "ON." Move the mixture control to "RICH" and the alternate air to "OPEN." Check the engine gauges for an indication of the cause of the power loss. If no fuel pressure is indicated, check the tank selector position to be sure it is on a tank containing fuel.

When power is restored move the alternate air to the "CLOSED" position and turn "OFF" the electric fuel pump.

If the preceding steps do not restore power, prepare for an emergency landing.

If time permits, turn the ignition switch to "L" then to "R" then back to "BOTH." Move the throttle and mixture control levers to different settings. This may restore power if the problem is too rich or too lean a mixture or if there is a partial fuel system restriction. Try other fuel tanks. Water in the fuel could take some time to be used up, and allowing the engine to windmill may restore power. If power loss is due to water, fuel pressure indications will be normal.

If engine failure was caused by fuel exhaustion power will not be restored after switching fuel tanks until the empty fuel lines are filled. This may require up to ten seconds.

If power is not regained, proceed with the Power Off Landing procedure (refer to the emergency check list and paragraph 3.13).

3.13 POWER OFF LANDING

On aircraft equipped with the backup gear extender, if loss of power occurs at altitude, lock emergency gear lever in **OVERRIDE ENGAGED** position before airspeed drops to 122mph IAS (106 KIAS) to prevent landing gear from inadvertently free falling. Then trim the aircraft for best gliding angle (106 mph IAS/92 kts IAS) (Air Cond. off) and look for a suitable field. If measures taken to restore power are not effective, and if time permits, check your charts for airports in the immediate vicinity; it may be possible to land at one if you have sufficient altitude. At best gliding angle, with no wind, with the engine windmilling, and the propeller control in full **DECREASE** rpm, the aircraft will travel approximately 1.6 miles for each thousand feet of altitude. If possible, notify the FAA by radio of your difficulty and intentions. If another pilot or passenger is aboard, let him help.

When you have located a suitable field, establish a spiral pattern around this field. Try to be at 1000 feet above the field at the downwind position, to make a normal landing approach. When the field can easily be reached, slow to 86 mph IAS (75 kts IAS) with flaps down for the shortest landing. Excess altitude may be lost by widening your pattern, using flaps or slipping, or a combination of these.

Whether to attempt a landing with gear up or down depends on many factors. If the field chosen is obviously smooth and firm, and long enough to bring the plane to a stop, the gear should be down. If there are stumps or rocks or other large obstacles in the field, the gear in the down position will better protect the occupants of the aircraft. If, however, the field is suspected to be excessively soft or short, or when landing in water of any depth, a wheels-up landing will normally be safer and do less damage to the airplane.

On airplanes equipped with the backup gear extender, the landing gear will free fall at airspeeds below approximately 118 mph IAS (103 KIAS) and, under normal conditions, will take approximately 10 seconds to be down and locked. If a gear up landing is desired, it will be necessary to latch the override lever in the **OVERRIDE ENGAGED** position before the airspeed drops to 122 mph IAS (106 KIAS) to prevent the landing gear from inadvertently free falling.

Touchdown should normally be made at the lowest possible airspeed.

(a) Gear Down Landing

When committed to a gear down emergency landing select landing gear **DOWN**, close the throttle control and shut **OFF** the master and ignition switches. Flaps may be used as desired. Turn the fuel selector valve to **OFF** and move the mixture to idle cut-off. The seat belts and shoulder harness (if installed) should be tightened. Touchdown should be normally made at the lowest possible airspeed.

NOTE

If the master switch is **OFF**, the gear cannot be retracted.

(b) Gear Up landing

On aircraft equipped with the backup gear extender, latch the emergency gear lever in the **VERRIDE ENGAGED** position, prior to reaching 122 mph IAS (106 KIAS), to prevent the gear from inadvertently extending, at airspeeds below 118 mph IAS (103 KIAS).

Touchdowns should normally be made at the lowest possible airspeed with full flaps.

When committed to landing, turn **OFF** the ignition and master switch. The fuel selector should be **OFF** and the mixture at idle cut-off.

Tighten the seat belts and shoulder harness (if installed).

3.15 FIRE IN FLIGHT

The presence of fire is noted through smoke, smell and heat in the cabin. It is essential that the source of the fire be promptly identified through instrument readings, character of the smoke, or other indications since the action to be taken differs somewhat in each case.

Check for the source of the fire first.

If an electrical fire is indicated (smoke in the cabin), the master switch should be turned **OFF**. The cabin vents should be opened and the cabin heat turned **OFF**. A landing should be made as soon as possible.

If an engine fire is present, switch the fuel selector to **OFF** and close the throttle. The mixture should be at idle cut-off. In all cases, the heater and defroster should be **OFF**. If the terrain permits, a landing should be made immediately.

NOTE

The possibility of an engine fire in flight is extremely remote. The procedure given is general and pilot judgment should be the determining factor for action in such an emergency.

3.17 LOSS OF OIL PRESSURE

Loss of oil pressure may be either partial or complete. A partial loss of oil pressure usually indicates a malfunction in the oil pressure regulating system, and a landing should be made as soon as possible to investigate the cause and prevent engine damage.

A complete loss of oil pressure indication may signify oil exhaustion or may be the result of a faulty gauge. In either case, proceed toward the nearest airport, and be prepared for a forced landing. If the problem is not a pressure gauge malfunction, the engine may stop suddenly. Maintain altitude until such time as a dead stick landing can be accomplished. Don't change power settings unnecessarily, as this may hasten complete power loss.

Depending on the circumstances, it may be advisable to make an off airport landing while power is still available, particularly if other indications of actual oil pressure loss, such as sudden increases in temperatures, or oil smoke, are apparent, and an airport is not close.

If engine stoppage occurs, proceed with Power Off Landing.

3.19 LOSS OF FUEL PRESSURE

If loss of fuel pressure occurs, turn "ON" the electric fuel pump and check that the fuel selector is on a full tank.

If the problem is not an empty tank, land as soon as practical and have the engine-driven fuel pump and fuel system checked.

3.21 HIGH OIL TEMPERATURE

An abnormally high oil temperature indication may be caused by a low oil level, an obstruction in the oil cooler, damaged or improper baffle seals, a defective gauge, or other causes. Land as soon as practical at an appropriate airport and have the cause investigated.

A steady, rapid rise in oil temperature is a sign of trouble. Land at the nearest airport and let a mechanic investigate the problem. Watch the oil pressure gauge for an accompanying loss of pressure.

3.23 ALTERNATOR FAILURE

Loss of alternator output is detected through zero reading on the ammeter. Before executing the following procedure, ensure that the reading is zero and not merely low by actuating an electrically powered device, such as the landing light. If no increase in the ammeter reading is noted, alternator failure can be assumed.

The electrical load should be reduced as much as possible. Check the alternator circuit breakers for a popped circuit.

The next step is to attempt to reset the overvoltage relay. This is accomplished by moving the ALT switch to OFF for one second and then to ON. If the trouble was caused by a momentary overvoltage condition (16.5 volts and up) this procedure should return the ammeter to a normal reading.

If the ammeter continues to indicate zero output, or if the alternator will not remain reset, turn off the ALT switch, maintain minimum electrical load and land as soon as practical. All electrical load is being supplied by the battery.

3.25 PROPELLER OVERSPEED

Propeller overspeed is caused by a malfunction in the propeller governor or low oil pressure which allows the propeller blades to rotate to full low pitch.

If propeller overspeed should occur, retard the throttle and check the oil pressure. The propeller control should be moved to full DECREASE rpm and then set if any control is available. Airspeed should be reduced and throttle used to maintain 2700 rpm.

3.27 EMERGENCY LANDING GEAR EXTENSION

Prior to proceeding with an emergency gear extension check to ensure that the master switch is ON and that the circuit breakers have not opened. If it is daytime, the radio lights should be turned off. Check the landing gear indicators for faulty bulbs.

NOTE

Refer to paragraph 4.39 for differences when emergency extension procedure is performed for training purposes.

If the landing gear does not check down and locked, reduce the airspeed to below 100 mph IAS (87 kts IAS). Move the landing gear selector to the DOWN position. On aircraft equipped with the backup gear extender, place the emergency gear lever in the OVERRIDE ENGAGED position and fish tail the airplane.

If the landing gear still does not check down and locked, position and *hold* the emergency gear lever in the EMERGENCY DOWN position while fish tailing the airplane. Under normal conditions, approximately 10 seconds will be required for the gear to extend and lock down.

If all electrical power has been lost, the landing gear must be extended using the above procedures. The gear position indicator lights will not illuminate.

3.29 SPIN RECOVERY

Intentional spins are prohibited in this airplane. If a spin is inadvertently entered, immediately move the throttle to idle and the ailerons to neutral.

Full rudder should then be applied opposite to the direction of rotation followed by control wheel full forward. When the rotation stops, neutralize the rudder and ease back on the control wheel as required to smoothly regain a level flight attitude.

3.31 OPEN DOOR

The cabin door on the Cherokee is double latched, so the chances of its springing open in flight at both the top and bottom are remote. However, should you forget the upper latch, or not fully engage the lower latch, the door may spring partially open. This will usually happen at takeoff or soon afterward. A partially open door will not affect normal flight characteristics, and a normal landing can be made with the door open.

If both upper and lower latches are open, the door will trail slightly open, and airspeed will be reduced slightly.

To close the door in flight, slow the airplane to 100 MPH IAS (87 KTS IAS), close the cabin vents and open the storm window. If the top latch is open, latch it. If the lower latch is open, open the top latch, push the door further open and close rapidly. Then secure the top latch.

A slip in the direction of the open door will assist in the latching procedure.

3.33 ENGINE ROUGHNESS

Engine roughness may be caused by dirt in the injector nozzles, induction system icing, or ignition problems.

First adjust the mixture for maximum smoothness. The engine will run rough if the mixture is too rich or too lean.

Move the alternate air to "OPEN" and then turn "ON" the electric fuel pump.

Switch the fuel selector to another tank to see if fuel contamination is the problem.

Check the engine gauges for abnormal readings. If any gauge readings are abnormal proceed accordingly.

The magneto switch should then be moved to "L" then "R," then back to "BOTH." If operation is satisfactory on either magneto, proceed on that magneto at reduced power with full "RICH" mixture to a landing at the first available airport.

If roughness persists, prepare for a precautionary landing at pilot's discretion.

THIS PAGE INTENTIONALLY LEFT BLANK

TABLE OF CONTENTS

SECTION 4

NORMAL PROCEDURES

Paragraph No.		Page No.
4.1	General	4-1
4.3	Airspeeds for Safe Operations	4-1
4.5	Normal Procedures Check List	4-3
	Preflight Check	4-3
	Before Starting Engine	4-4
	Starting Engine When Cold	4-4
	Starting Engine When Hot	4-4
	Starting Engine When Flooded	4-4
	Starting Engine With External Power Source	4-4
	Warm-Up	4-4
	Taxiing	4-4
	Ground Check	4-4
	Before Takeoff	4-5
	Takeoff	4-5
	Climb	4-5
	Cruising	4-5
	Approach and Landing	4-6
	Stopping Engine	4-6
	Parking	4-6
4.7	Amplified Normal Procedures (General)	4-7
4.9	Preflight Check	4-7
4.11	Before Starting Engine	4-8
4.13	Starting Engine	4-9
4.15	Warm-Up	4-11
4.17	Taxiing	4-11
4.19	Ground Check	4-11
4.21	Before Takeoff	4-12
4.23	Takeoff	4-13
4.25	Climb	4-13
4.27	Cruising	4-14
4.29	Approach and Landing	4-15
4.31	Stopping Engine	4-15
4.33	Parking	4-15
4.35	Stalls	4-16
4.37	Turbulent Air Operation	4-16
4.39	Landing Gear	4-17
4.41	Weight and Balance	4-17

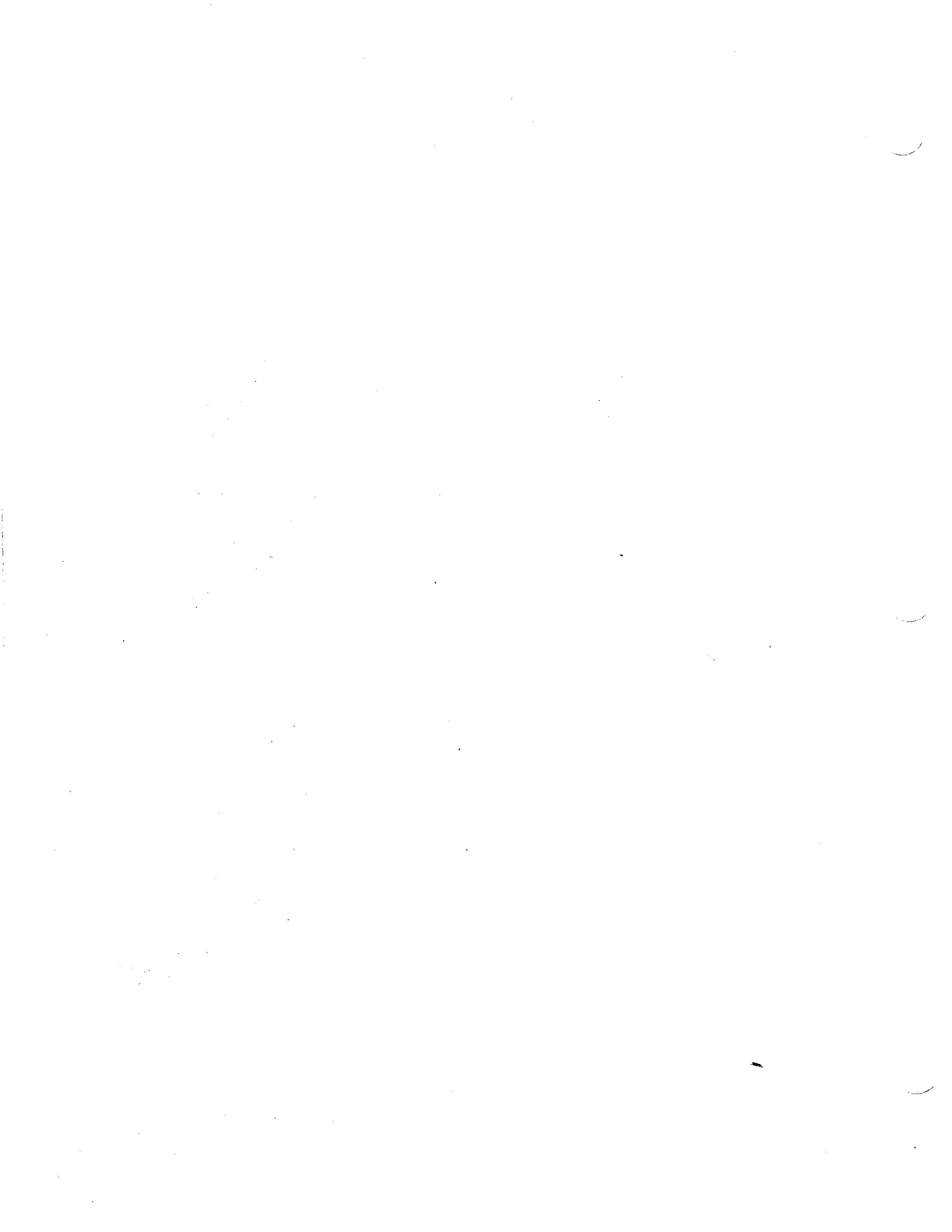

SECTION 4 NORMAL PROCEDURES

4.1 GENERAL

This section clearly describes the recommended procedures for the conduct of normal operations for the Cherokee Lance. All of the required (FAA regulations) procedures and those necessary for the operation of the airplane as determined by the operating and design features of the airplane are presented.

Normal procedures associated with those optional systems and equipment which require handbook supplements are provided in Section 9 (Supplements).

These procedures are provided to present a source of reference and review and to supply information on procedures which are not the same for all aircraft. Pilots should familiarize themselves with the procedures given in this section in order to become proficient in the normal operations of the airplane.

The first portion of this section consists of a short form check list which supplies an action sequence for normal operations with little emphasis on the operation of the systems.

The remainder of the section is devoted to amplified normal procedures which provide detailed information and explanations of the procedures and how to perform them. This portion of the section is not intended for use as an in-flight reference due to the lengthy explanations. The short form check list should be used for this purpose.

4.3 AIRSPEEDS FOR SAFE OPERATIONS

The following airspeeds are those which are significant to the operation of the airplane. These figures are for standard airplanes flown at gross weight under standard conditions at sea level.

Performance for a specific airplane may vary from published figures depending upon the equipment installed, the condition of the engine, airplane and equipment, atmospheric conditions and piloting technique.

- | | |
|---|-------------------|
| (a) Best Rate of Climb Speed (IAS) | |
| gear up, flaps up | 106 MPH (92 KTS) |
| gear down, flaps up | 100 MPH (87 KTS) |
| (b) Best Angle of Climb Speed (IAS) | |
| gear up, flaps up | 100 MPH (87 KTS) |
| gear down, flaps up | 78 MPH (68 KTS) |
| (c) Turbulent Air Operating Speed (IAS) | 122 MPH (106 KTS) |
| (d) Landing Approach Speed (IAS) | 86 MPH (75 KTS) |
| (e) Maximum Demonstrated Crosswind Velocity | 20 MPH (17 KTS) |

THIS PAGE INTENTIONALLY LEFT BLANK

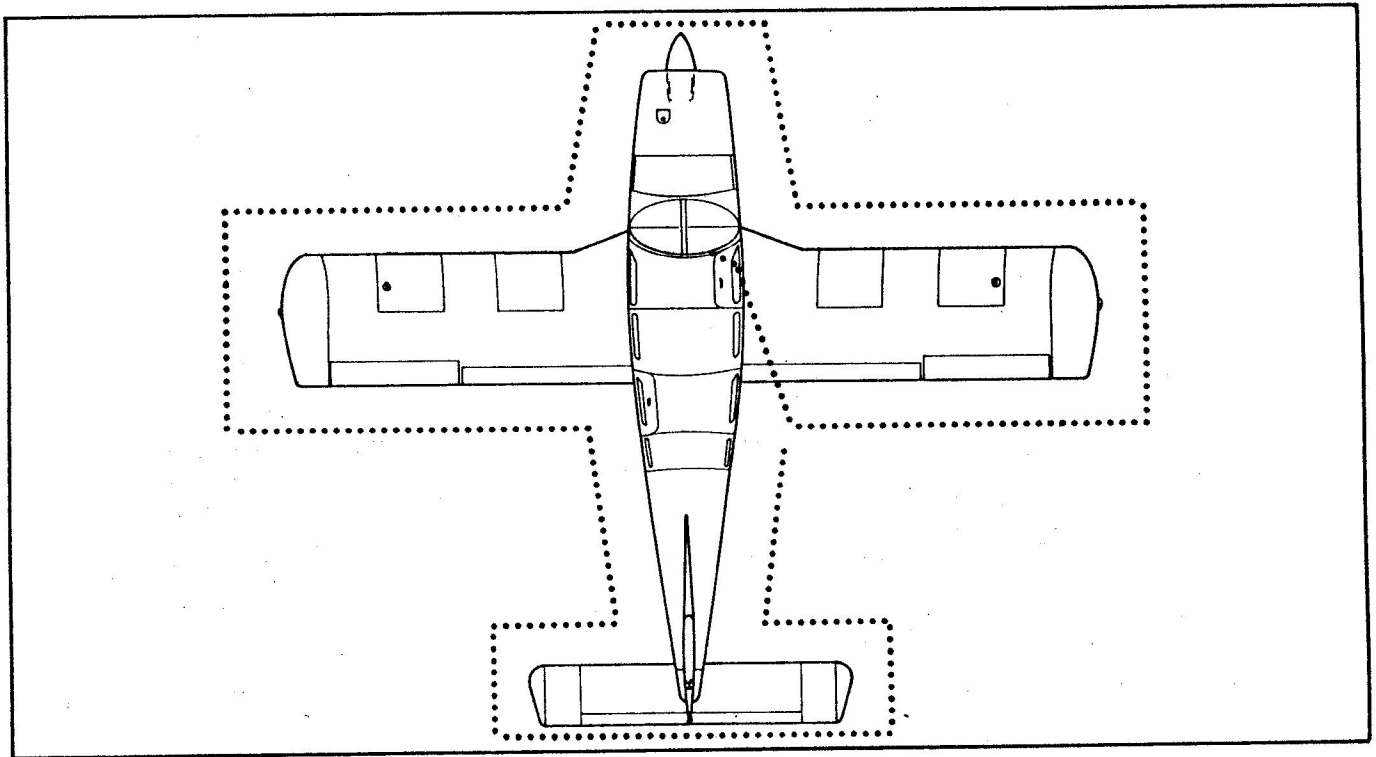

WALK-AROUND

Figure 4-1

4.5 NORMAL PROCEDURES CHECK LIST

PREFLIGHT CHECK

- Control wheel release belts
- Parking brake set
- Master switch ON
- Fuel quantity gauges check
- Master switch OFF
- Ignition OFF
- Exterior check for damage
- Control surfaces check for interference - free of ice, snow, frost
- Hinges check for interference
- Wings free of ice, snow, frost
- Stall warning check
- Navigation lights check
- Fuel tanks check supply visually - secure caps
- Fuel tank sumps drain and check for water, sediment and proper fuel
- Fuel vents open
- Main gear struts proper inflation (4.0 in.)
- Tires check
- Brake blocks check

- Pitot heat remove cover - holes clear
- Windshield clean
- Propeller and spinner check
- Fuel and oil check for leaks
- Oil check level
- Dipstick properly seated
- Cowling secure
- Inspection covers secure
- Nose wheel tire check
- Nose gear strut proper inflation (2.60 in.)
- Air inlets clear
- Alternator belt check tension
- Tow bar and control locks stow
- Baggage stowed properly - secure
- Baggage door close and secure
- Fuel strainer drain and check for water, sediment and proper fuel
- Primary flight controls proper operation
- Cabin doors close and secure
- Required papers on board
- Seat belts and harness fastened - check inertia reel

4.7 AMPLIFIED NORMAL PROCEDURES (GENERAL)

The following paragraphs are provided to supply detailed information and explanations of the normal procedures necessary for the operation of the airplane.

4.9 PREFLIGHT CHECK

The airplane should be given a thorough preflight and walk-around check. The preflight should include a check of the airplane's operational status, computation of weight and C.G. limits, takeoff distance and in-flight performance. A weather briefing should be obtained for the intended flight path, and any other factors relating to a safe flight should be checked before takeoff.

Upon entering the cockpit, release the seat belts securing the control wheel and set the parking brake. Turn "ON" the master switch and check the fuel quantity gauges for sufficient fuel. After the fuel quantity check is made turn the master switch "OFF" and the ignition switch "OFF."

To begin the exterior walk-around, check for external damage and operational interference of the control surfaces or hinges. Insure that the wings and control surfaces are free of snow, ice, frost or any other foreign materials.

An operational check of the stall warning system should now be made by turning the master switch "ON," lifting the detector and checking to determine if the horn is actuated. The master switch should be returned to the "OFF" position after the check is complete.

The next step is to check the navigation lights. The master switch must be "ON" for this check.

A visual check of the fuel tank quantity should be performed. Remove the filler cap from each tank and visually check the supply. Be sure to secure the caps properly after the check is complete. Each inboard tank is furnished with an external fuel quantity indicator to assist the pilot in determining fuel quantities of less than 25 gallons. A visual check of this indicator should also be made.

The fuel system should be drained daily prior to the first flight and after refueling to check for water, sediment and proper fuel. Each fuel tank is equipped with an individual quick drain located at the lower inboard rear corner of the tank. The fuel strainer and a system quick drain valve are located in the fuselage at the lowest point of the fuel system. It is important that the fuel system be drained properly.

Drain each tank through its individual quick drain located at the lower inboard rear corner of the tank, making sure that enough fuel has been drained to insure that all water and sediment is removed.

Next, place a container under the fuel sump drain outlet located under the fuselage.

Now drain the fuel strainer by pressing down on the lever located on the right hand side of the cabin below the forward edge of the rear seat. The fuel selector should be positioned in the following sequence while draining the strainer: "OFF," "LEFT," "RIGHT." This is done to insure that the fuel lines between each tank outlet and fuel strainer are drained as well as the strainer. When the fuel tanks are full, it will take approximately six seconds to drain all the fuel in one of the lines from a tank to the fuel strainer. When the fuel tanks are less than full, it will take a few seconds longer.

Examine the contents of the container placed under the fuel sump drain outlet for water, sediment and proper fuel and dispose of the contents.

CAUTION

When draining any amount of fuel, care should be taken to insure that no fire hazard exists before starting engine.

After using the under-seat quick drain, it should be checked from outside to make sure it has closed completely and is not leaking.

Check all of the fuel tank vents to make sure they are open.

Next, a complete check of the landing gear. Check the main gear shock struts for proper inflation. There should be 4.0 inches of strut exposure under a normal static load. The nose gear should be checked for 2.60 inches of strut exposure. Check all tires for cuts and wear and insure proper inflation. Make a visual check of the brake blocks for wear or damage.

Remove the cover from the pitot head on the underside of the left wing. Check the pitot head to make sure the holes are open and clear of obstructions.

Don't forget to clean and check the windshield.

The propeller and spinner should be checked for defects or nicks.

Lift the cowling and check for any obvious fuel or oil leaks. Check the oil level. Make sure that the dipstick has properly seated after checking. Secure the cowling and check the inspection covers.

Check the air inlets for foreign matter and the alternator belt for proper tension.

Stow the tow bar and check the baggage for proper storage and security. The baggage compartment doors should be closed and secure.

Upon entering the aircraft, ascertain that all primary flight controls operate properly. Close and secure the fore and aft cabin doors and check that all the required papers are in order and in the airplane.

Fasten the seat belts and shoulder harness and check the function of the inertia reel by pulling sharply on the strap.

4.11 BEFORE STARTING ENGINE

Before starting the engine the parking brake should be set "ON" and the propeller lever moved to the full "INCREASE" rpm position. The fuel selector should then be moved to the desired tank.

4.13 STARTING ENGINE

(a) Starting Engine When Cold

Open the throttle lever approximately 1/2 inch. Turn "ON" the master switch and the electric fuel pump. Move the mixture control to full "RICH" until an indication is noted on the fuel flow meter. The engine is now primed.

Move the mixture control to idle cut-off and engage the starter by rotating the magneto switch clockwise and pressing in. When the engine fires, release the magneto switch, advance the mixture control to full "RICH" and move the throttle to the desired setting.

If the engine does not fire within five to ten seconds, disengage the starter and reprime.

(b) Starting Engine When Hot

Open the throttle approximately 1/2 inch. Turn "ON" the master switch and the electric fuel pump. Move the mixture control lever to idle cut-off and engage the starter by rotating the magneto switch clockwise and pressing in. When the engine fires, release the magneto switch, advance the mixture and move the throttle to the desired setting.

(c) Starting Engine When Flooded

The throttle lever should be full "OPEN." Turn "ON" the master switch and turn "OFF" the emergency fuel pump. Move the mixture control lever to idle cut-off and engage the starter by rotating the magneto switch clockwise and pressing in. When the engine fires, release the magneto switch, advance the mixture and retard the throttle.

(d) Starting Engine With External Power Source

An optional feature called the Piper External Power (PEP) allows the operator to use an external battery to crank the engine without having to gain access to the airplane's battery.

Turn the airplane master switch "OFF." Connect the RED lead of the PEP kit jumper cable to the POSITIVE (+) terminal of an external 12-volt battery and the BLACK lead to the NEGATIVE (-) terminal. Insert the plug of the jumper cable to the socket located on the fuselage.

Turn "ON" the airplane master switch and proceed with the normal engine starting procedure.

After the engine has started, turn the master switch "OFF" and disconnect the jumper cable from the airplane. Return the master switch to the "ON" position and check the alternator ammeter for an indication of output. **DO NOT ATTEMPT FLIGHT IF THERE IS NO INDICATION OF ALTERNATOR OUTPUT.**

When the engine is firing evenly, advance the throttle to 800 RPM. If oil pressure is not indicated within thirty seconds, stop the engine and determine the trouble. In cold weather it will take a few seconds longer to get an oil pressure indication. If the engine has failed to start, refer to the Lycoming Operating Handbook, Engine Troubles and Their Remedies.

Starter manufacturers recommend that cranking periods be limited to thirty seconds with a two minute rest between cranking periods. Longer cranking periods will shorten the life of the starter.

THIS PAGE INTENTIONALLY LEFT BLANK

4.15 WARM-UP

Warm-up the engine at 1000 to 1200 RPM. Avoid prolonged idling at low RPM, as this practice may result in fouled spark plugs.

Takeoff may be made as soon as the ground check is completed, provided that the throttle may be opened fully without backfiring or skipping, and without a reduction in engine oil pressure.

Do not operate the engine at high RPM when running up or taxiing over ground containing loose stones, gravel or any loose material that may cause damage to the propeller blades.

4.17 TAXIING

Before attempting to taxi the airplane, ground personnel should be instructed and approved by a qualified person authorized by the owner. Ascertain that the wheel chocks have been removed and propeller back blast and taxi areas are clear. Release the parking brake.

Power should be applied slowly to start the taxi roll. Taxi a few feet forward and apply the brakes to determine their effectiveness. Taxi with the propeller set in low pitch, high RPM setting. While taxiing, make slight turns to ascertain the effectiveness of the steering.

Observe wing clearances when taxiing near buildings or other stationary objects. If possible, station an observer outside the airplane.

Avoid holes and ruts when taxiing over uneven ground.

Do not operate the engine at high RPM when running up or taxiing over ground containing loose stones, gravel or any loose material that may cause damage to the propeller blades.

4.19 GROUND CHECK

Set the parking brake. The magnetos should be checked at 2000 RPM with the propeller set at high RPM. Drop off on either magneto should not exceed 175 RPM and the difference between the magnetos should not exceed 50 RPM. Operation on one magneto should not exceed 10 seconds.

Check the vacuum gauge; the indicator should read $5.0" \pm .1" \text{ Hg}$ at 2000 RPM.

Check both oil temperature and oil pressure. The temperature may be low for some time if the engine is being run for the first time of the day, but as long as the pressure is within limits the engine is ready for takeoff.

Check the annunciator panel lights with the press-to-test button. Also check the air conditioner and the alternate air.

The propeller control should be moved through its complete range to check for proper operation, and then placed in full "INCREASE" rpm for takeoff. To obtain maximum rpm, push the pedestal mounted control fully forward on the instrument panel. Do not allow a drop of more than 500 RPM during this check. In cold weather the propeller control should be cycled from high to low RPM at least three times before takeoff to make sure that warm engine oil has circulated.

The electric fuel pump should be turned "OFF" after starting or during warm-up to make sure that the engine driven pump is operating. Prior to takeoff the electric pump should be turned ON again to prevent loss of power during takeoff should the engine driven pump fail. The engine is warm enough for takeoff when the throttle can be opened without the engine faltering.

4.21 BEFORE TAKEOFF

All aspects of each particular takeoff should be considered prior to executing the takeoff procedure.

After takeoff, if the gear selector switch is placed in the gear up position before reaching the airspeed at which the back up gear extender system no longer commands gear down*, the gear will not retract. For obstacle clearance on takeoff and for takeoffs from high altitude airports, the landing gear can be retracted after lift-off at the pilot's discretion by placing the gear selector switch in the "UP" position and then latching the emergency gear lever in the "OVERRIDE ENGAGED" position. If desired, the "OVERRIDE ENGAGED" position can be selected and latched before takeoff, and the gear will then retract as soon as the gear selector switch is placed in the "UP" position. Care should always be taken not to retract the gear prematurely, or the aircraft could settle back onto the runway. If the override lock is used for takeoff, it should be disengaged as soon as sufficient airspeed and terrain clearance are obtained, to return the gear system to normal operation.

For normal operation, the pilot should extend and retract the gear with the gear selector switch located on the instrument panel, just as he would if the back-up gear extender system were not installed.

If the airplane is to be operated with the rear cabin door removed, it is recommended that all passengers wear parachutes.

After all aspects of the takeoff are considered, a pretakeoff check procedure must be performed.

Turn "ON" the master switch and check and set all of the flight instruments as required. Check the fuel selector to make sure it is on the proper tank (fullest). Turn "ON" the electric fuel pump and check the engine gauges. The alternate air should be in the "CLOSED" position.

All seat backs should be erect.

The mixture and propeller control levers should be set and the seat belts and shoulder harness fastened. Fasten the seat belts snugly around the empty seats.

Exercise and set the flaps and trim tab. Insure proper flight control movement and response.

All doors should be properly secured and latched.

On air conditioned models, the air conditioner must be "OFF" to insure normal takeoff performance. Release the parking brake.

*Approximately 93 MPH IAS, (81 KTS IAS) at sea level to approximately 115 MPH IAS, (100 KTS IAS) at 10,000 ft. with a straight line variation between.

4.23 TAKEOFF

The normal takeoff technique is conventional for the Cherokee Lance. The tab should be set slightly aft of neutral, with the exact setting determined by the loading of the airplane. Allow the airplane to accelerate to 60 to 75 MPH IAS (52 to 65 KTS IAS) depending on the weight of the aircraft and ease back on the control wheel to rotate to climb attitude.

The procedure used for a short field takeoff with an obstacle clearance or a soft field takeoff differs slightly from the normal technique. The flaps should be lowered to 25° (second notch). Allow the aircraft to accelerate to 46 to 61 MPH IAS (40 to 53 KTS IAS) depending on the aircraft weight and rotate the aircraft to climb attitude. After breaking ground, accelerate to 60-67 MPH IAS (52 to 58 KTS IAS), depending on aircraft weight and select gear up*. Continue to climb while accelerating to the flaps-up rate of climb speed, 106 MPH IAS (92 KTS IAS) if no obstacle is present or 100 MPH IAS (87 KTS IAS) if obstacle clearance is a consideration. Slowly retract the flaps while climbing out.

4.25 CLIMB

The best rate of climb at gross weight will be obtained at 106 MPH IAS (92 KTS IAS). The best angle of climb may be obtained at 100 MPH IAS (87 KTS IAS). At lighter than gross weight these speeds are reduced somewhat.** For climbing en route, a speed of 120 MPH IAS (104 KTS IAS) is recommended. This will produce better forward speed and increased visibility over the nose during the climb.

When reaching the desired altitude, the electric fuel pump may be turned off.

*If desired, the override up position can be selected and latched before takeoff, and the gear will then retract as soon as the gear selector switch is placed in the up position. In this case care should be taken not to retract the gear prematurely, or the aircraft could settle back onto the runway. If the override lock is used for takeoff, it should be disengaged as soon as sufficient terrain clearance is obtained, to return the gear system to normal operation.

**To obtain the performance presented in the Performance Section of this handbook, full power (full throttle and 2700 RPM) must be used.

4.27 CRUISING

The cruising speed of the Cherokee Lance is determined by many factors, including power setting, altitude, temperature, loading and equipment installed in the airplane.

The normal maximum cruising power is 75% of the rated horsepower of the engine. When selecting cruising RPM below 2300, limiting manifold pressure for continuous operation, as specified by the appropriate "Avco-Lycoming Operator's Manual," should be observed.

To obtain the desired power, set the manifold pressure and RPM according to the power setting table in this manual.

Use of the mixture control in cruising flight reduces fuel consumption significantly, especially at higher altitudes. The mixture should be leaned during cruising operation above 5000 ft. altitude and at pilot's discretion at lower altitudes when 75% power or less is being used. If any doubt exists as to the amount of power being used, the mixture should be in the full "RICH" position for all operations under 5000 feet.

To lean the mixture, disengage the lock and pull the mixture control until the engine becomes rough, indicating that the lean mixture limit has been reached in the leaner cylinders. Then enrich the mixture by pushing the control towards the instrument panel until engine operation becomes smooth. The fuel flow meter will give a close approximation of the fuel being consumed. The low side of the power setting, as shown on the fuel flow meter, indicates best economy for that percent of power while the high side indicates best power.

If the airplane is equipped with the optional exhaust gas temperature (EGT) gauge, a more accurate means of leaning is available to the pilot. For this procedure, refer to the "Avco-Lycoming Operator's Manual."

In order to keep the airplane in best lateral trim during cruise flight, the fuel should be used alternately from each tank at one hour intervals.

Always remember that the electric fuel pump should be turned "ON" before switching tanks, and should be left on for a short period thereafter. To preclude making a hasty selection, and to provide continuity of flow, the selector should be changed to another tank before fuel is exhausted from the tank in use. The electric fuel pump should be normally "OFF" so that any malfunction of the engine driven fuel pump is immediately apparent. If signs of fuel starvation should occur at any time during flight, fuel exhaustion should be suspected, at which time the fuel selector should be immediately positioned to a full tank and the electric fuel pump switched to the "ON" position.

4.29 APPROACH AND LANDING

Check to insure the fuel selector is on the proper (fullest) tank and that the seat backs are erect. The seat belts and shoulder harness should be fastened and the inertia reel checked.

Turn "ON" the electric fuel pump and turn "OFF" the air conditioner. The mixture should be set in the full "RICH" position. Set the propeller at full "INCREASE" rpm to facilitate ample power for an emergency go-around and to prevent overspeeding of the engine if the throttle is advanced sharply.

The landing gear may be extended at speeds below 150 MPH CAS (130 KTS CAS). The airplane should be trimmed to an approach speed of about 86 MPH IAS (75 KTS IAS) with flaps extended. The flaps can be lowered at speeds up to 125 MPH CAS (109 KTS CAS), if desired.

The mixture control should be kept in full "RICH" position to insure maximum acceleration if it should be necessary to open the throttle again.

The amount of flap used during landings and the speed of the aircraft at contact with the runway should be varied according to the landing surface and conditions of wind and airplane loading. It is generally good practice to contact the ground at the minimum possible safe speed consistent with existing conditions.

Normally, the best technique for short and slow landings is to use full flap and enough power to maintain the desired airspeed and approach flight path. Mixture should be full "RICH," fuel on the fullest tank, and electric fuel pump "ON." Reduce the speed during the flareout and contact the ground close to the stalling speed. After ground contact hold the nose wheel off as long as possible. As the airplane slows down, gently lower the nose and apply the brakes. Braking is most effective when flaps are raised and back pressure is applied to the control wheel, putting most of the aircraft weight on the main wheels. In high wind conditions, particularly in strong crosswinds, it may be desirable to approach the ground at higher than normal speeds with partial or no flaps.

4.31 STOPPING ENGINE

At the pilot's discretion, the flaps should be raised and the electric fuel pump turned "OFF." The air conditioner and radios should be turned "OFF," the propeller set in the full "INCREASE" position, and the engine stopped by disengaging the mixture control lock and pulling the mixture control back to idle cut-off. The throttle should be left full aft to avoid engine vibration while stopping. Then the magneto and master switches must be turned "OFF."

4.33 PARKING

If necessary, the airplane should be moved on the ground with the aid of the nose wheel tow bar provided with each airplane and secured behind the rear seats. The aileron and stabilator controls should be secured by looping the safety belt through the control wheel and pulling it snug. The flaps are locked when in the "UP" position and should be left retracted.

Tie downs can be secured to rings provided under each wing and to the tail skid. The rudder is held in position by its connections to the nose wheel steering and normally does not have to be secured.

4.35 STALLS

The stall characteristics of the Cherokee Lance are conventional. An approaching stall is indicated by a stall warning horn which is activated between five and ten miles per hour above stall speed. Mild airframe buffeting and gentle pitching may also precede the stall.

The gross weight stalling speed of the Cherokee Lance with power off and full flaps is 70 MPH CAS (61 KTS CAS). With the flaps up this speed is increased 7 MPH (6 KTS). Loss of altitude during stalls can be as great as 400 feet, depending on configuration and power.

The following performance figures were obtained during FAA type tests and may be realized under conditions indicated with the airplane and engine in good condition and with average piloting technique. All performance is given for 3600 pounds. Stall speeds at lower weights will be correspondingly less.

The loss of altitude during stalls may be as much as 400 feet, depending on configuration and power.

Stalling speeds, in mph, power off, versus angle of bank (calibrated airspeed):

Angle of Bank		0°	20°	40°	50°	60°
Gear Down - Flaps Up	MPH	77	79	88	96	109
	KTS	67	69	76	83	95
Gear Down - Flaps - 10° (First Notch)	MPH	75	77	86	94	106
	KTS	65	67	74	81	92
Gear Down - Flaps - 25° (Second Notch)	MPH	71	73	81	89	100
	KTS	62	64	71	77	87
Gear Down - Flaps - 40° (Third Notch)	MPH	70	72	80	87	99
	KTS	61	63	69	76	86

NOTE

The stall warning system is inoperative with the master switch "OFF."

During preflight, the stall warning system should be checked by turning the master switch "ON," lifting the detector and checking to determine if the horn is actuated. The master switch should be returned to the "OFF" position after the check is complete.

4.37 TURBULENT AIR OPERATION

In keeping with good operating practice used in all aircraft, it is recommended that when turbulent air is encountered or expected, the airspeed be reduced to maneuvering speed to reduce the structural loads caused by gusts and to allow for inadvertent speed build-ups which may occur as a result of the turbulence or of distractions caused by the conditions.

4.39 LANDING GEAR

This airplane is equipped with an airspeed - power sensing system (back-up gear extender) which extends the landing gear under low airspeed - power conditions* even though the pilot may not have selected gear down. This system will also prevent retraction of the landing gear by normal means when the airspeed - power values are below a predetermined minimum. To override this system or to hold the emergency gear lever in the "OVERRIDE ENGAGED" position without maintaining manual pressure on the emergency gear lever, pull the lever full up and push the latch down. To release the override, pull lever up to disengage the latch, then release lever.

For normal operation, the pilot should extend and retract the gear with the gear selector switch located on the instrument panel, just as he would if the back-up gear extender system were not installed.

The pilot should become familiar with the function and significance of the landing gear position indicators and warning lights.

The red gear warning light on the instrument panel and the horn operate simultaneously in flight when the throttle is reduced to where the manifold pressure is approximately 14 inches of mercury or below, and the gear selector switch is not in the "DOWN" position. This warning will also occur during flight when the back-up gear extended system has lowered the landing gear and the gear selector switch is not in the "DOWN" position and the throttle is not full "OPEN."

The red gear warning light on the instrument panel and the horn will also operate simultaneously on the ground when the master switch is "ON" and the gear selector switch is in the "UP" position.

The three green lights on the instrument panel operate individually as each associated gear is locked in the extended position.

WARNING

Radio lights' dimmer switch must be off to obtain gear lights full intensity during daytime flying. When aircraft is operated at night and radio lights' dimmer switch is turned on, gear lights will automatically dim.

The yellow "Auto Ext. OFF" light immediately below the gear selector switch flashes whenever the emergency gear lever is in the "OVERRIDE ENGAGED" position.

4.41 WEIGHT AND BALANCE

It is the responsibility of the owner and pilot to determine that the airplane remains within the allowable weight vs. center of gravity envelope while in flight.

For weight and balance data, refer to Section 6 (Weight and Balance).

*Approximately 118 MPH IAS, (103 KTS IAS) at any altitude, power off.

THIS PAGE INTENTIONALLY LEFT BLANK

TABLE OF CONTENTS

SECTION 5

PERFORMANCE

Paragraph No.		Page No.
5.1	General	5-1
5.3	Introduction to Performance and Flight Planning	5-1
5.5	Flight Planning Example	5-3
5.7	Performance Graphs	5-9
	List of Figures	5-9

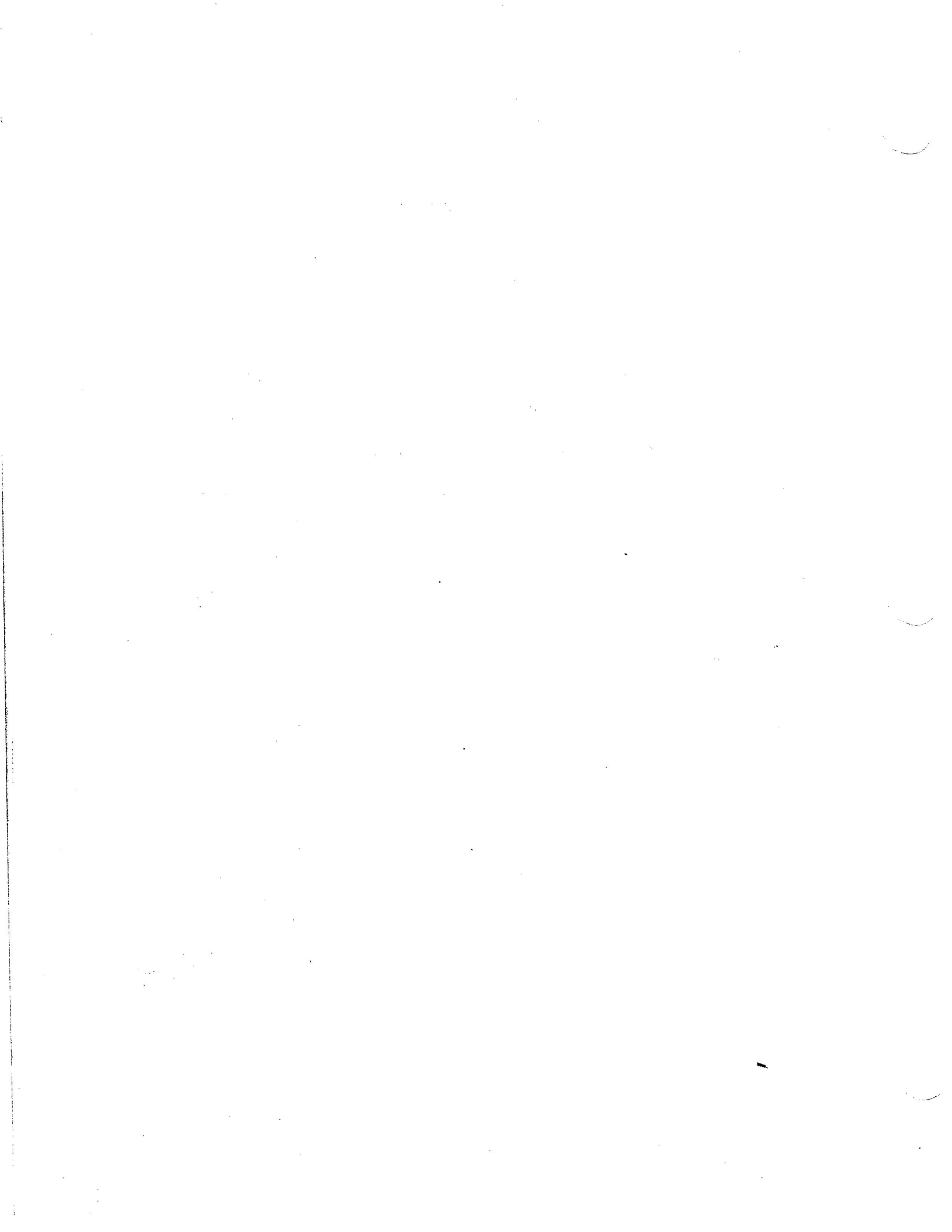

**SECTION 5
PERFORMANCE**

5.1 GENERAL

All of the required (FAA regulations) and complementary performance information applicable to the Cherokee Lance is provided in this section.

Performance information associated with those optional systems and equipment which require handbook supplements is provided in Section 9 (Supplements).

5.3 INTRODUCTION TO PERFORMANCE AND FLIGHT PLANNING

The performance information presented in this section is based on measured Flight Test Data corrected to I.C.A.O. standard day conditions and analytically expanded for the various parameters of weight, altitude, temperature, etc.

The performance charts are unfactored and do not make any allowance for varying degrees of pilot proficiency or mechanical deterioration of the aircraft. This performance, however, can be duplicated by following the stated procedures in a properly maintained airplane.

Effects of conditions not considered on the charts must be evaluated by the pilot, such as the effect of soft or grass runway surface on takeoff and landing performance, or the effect of winds aloft on cruise and range performance. Endurance can be grossly affected by improper leaning procedures, and inflight fuel flow and quantity checks are recommended.

REMEMBER! To get chart performance, follow the chart procedures.

The information provided by paragraph 5.5 (Flight Planning Example) outlines a detailed flight plan using the performance charts in this section. Each chart includes its own example to show how it is used.

WARNING

Performance information derived by extrapolation beyond the limits shown on the charts should not be used for flight planning purposes.

THIS PAGE INTENTIONALLY LEFT BLANK

5.5 FLIGHT PLANNING EXAMPLE

(a) Aircraft Loading

The first step in planning the flight is to calculate the airplane weight and center of gravity by utilizing the information provided by Section 6 (Weight and Balance) of this handbook.

The basic empty weight for the airplane as licensed at the factory has been entered in Figure 6-5. If any alterations to the airplane have been made effecting weight and balance, reference to the aircraft logbook and Weight and Balance Record (Figure 6-7) should be made to determine the current basic empty weight of the airplane.

Make use of the Weight and Balance Loading Form (Figure 6-13) and the C.G. Range and Weight graph (Figure 6-15) to determine the total weight of the airplane and the center of gravity position.

After proper utilization of the information provided the following weights have been determined for consideration in the flight planning example.

The landing weight cannot be determined until the weight of the fuel to be used has been established [refer to item (g) (1)].

(1) Basic Empty Weight	2100 lbs.
(2) Occupants (6 x 170 lbs)	1020 lbs.
(3) Baggage and Cargo	60 lbs.
(4) Fuel (6 lb/gal x 50)	<u>300 lbs.</u>
(5) Takeoff Weight	3480 lbs.
(6) Landing Weight	
(a)(5) minus (g)(1), (3480 lbs. minus 89 lbs.)	3391 lbs.

The takeoff weight is below the maximum of 3600 lbs. and the weight and balance calculations have determined the C.G. position within the approved limits.

(b) Takeoff and Landing

After determining the aircraft loading, all aspects of takeoff and landing must be considered.

All of the existing conditions at the departure and destination airport must be acquired, evaluated and maintained throughout the flight.

Apply the departure airport conditions and takeoff weight to the appropriate Takeoff Performance and Takeoff Ground Roll graph (Figures 5-7, 5-8, 5-9 and 5-10) to determine the length of runway necessary for the takeoff and/or the barrier distance.

The landing distance calculations are performed in the same manner using the existing conditions at the destination airport and, when established, the landing weight.

The conditions and calculations for the example flight are listed below. The takeoff and landing distances required for the example flight have fallen well below the available runway lengths.

	Departure Airport	Destination Airport
(1) Elevation	1200 ft.	400 ft.
(2) Temperature	60°F	75°F
(3) Wind Component	10 KTS	0 KTS
(4) Runway Length Available	3000 ft.	4600 ft.
(5) Runway Required	2240 ft.*	1680 ft.**

NOTE

The remainder of the performance charts used in this flight plan example assume a no wind condition. The effect of winds aloft must be considered by the pilot when computing climb, cruise and descent performance.

(c) Climb

The next step in the flight plan example is to determine the necessary climb segment components.

The desired cruise altitude and corresponding cruise temperature values are the first variables to be considered in determining the climb components from the Fuel, Distance, and Time to Climb graph (Figure 5-15). After the fuel, distance and time for the cruise altitude and temperature values have been established, apply the existing conditions at the departure field to graph (Figure 5-15). Now, subtract the values obtained from the graph for the field of departure conditions from those for the cruise elevation.

The remaining values are the true fuel, distance and time components for the climb segment of the flight plan corrected for field altitude and temperature.

The following values were determined from the above instructions in the flight planning example.

(1) Cruise Altitude	6000 ft.
(2) Cruise Altitude Temperature	42°F
(3) Time to Climb (8 min. minus 1 min.)	7 min.***
(4) Distance to Climb (16 miles minus 3 miles)	13 miles***
(5) Fuel to Climb (3.2 gal. minus 0.4 gal.)	2.8 gal.***

*reference Figure 5-9

**reference Figure 5-31

***reference Figure 5-15

(d) Descent

The descent data will be determined prior to the cruise data to provide the descent distance for establishing the total cruise distance.

Utilizing the cruise altitude and temperature, determine the basic fuel, distance and time for descent (Figure 5-27). These figures must be adjusted for the field elevation and temperature at the destination airport. To find the necessary adjustment values, use the existing altitude and temperature conditions at the destination airport as variables to find the fuel, distance and time values from the graph (Figure 5-27). Now, subtract the values obtained from the field conditions from the values obtained from the cruise conditions to find the true fuel, distance and time values needed for the flight plan.

The values obtained by proper utilization of the graphs for the descent segment of the example are shown below:

(1) Time to Descend (12.5 min. minus 2.5 min.)	10 min.*
(2) Distance to Descend (38 miles minus 8 miles)	30 miles*
(3) Fuel to Descend (4 gal. minus 1 gal.)	3 gal.*

(e) Cruise

Using the total distance to be traveled during the flight, subtract the previously calculated distance to climb and distance to descend to establish the total cruise distance. Refer to the appropriate Avco Lycoming Operator's Manual and the Power Setting Table (Figure 5-17) when selecting the cruise power setting. The established altitude and temperature values and the selected cruise power should now be utilized to determine the true airspeed from the appropriate Speed Power graph (Figure 5-19 or 5-21).

Calculate the cruise fuel flow for the cruise power setting from the information provided by the Avco Lycoming Operator's Manual.

The cruise time is found by dividing the cruise distance by the cruise speed and the cruise fuel is found by multiplying the cruise fuel flow by the cruise time.

The cruise calculations established for the cruise segment of the flight planning example are as follows:

(1) Total Distance	150 miles
(2) Cruise Distance (e)(1) minus (c)(4) minus (d)(2), (150 miles minus 13 miles minus 30 miles)	107 miles
(3) Cruise Power	65% rated power
(4) Cruise Speed	163 MPH TAS**
(5) Cruise Fuel Consumption	13.8 GPH
(6) Cruise Time (e)(2) divided by (e)(4), (107 miles divided by 163 MPH)	.656 hrs.
(7) Cruise Fuel (e)(5) multiplied by (c)(6), (13.8 GPH multiplied by .656 hrs.)	9.1 gal.

*reference Figure 5-27

**reference Figure 5-21

(f) Total Flight Time

The total flight time is determined by adding the time to climb, the time to descend and the cruise time. Remember! The time values taken from the climb and descent graphs are in minutes and must be converted to hours before adding them to the cruise time.

The following flight time is required for the flight planning example.

(1) Total Flight Time
(c)(3) plus (d)(1) plus (e)(6), (.12 hrs. plus .17 hrs. plus .656 hrs.) .946 hrs.

(g) Total Fuel Required

Determine the total fuel required by adding the fuel to climb, the fuel to descend and the cruise fuel. When the total fuel (in gallons) is determined, multiply this value by 6 lb/gal to determine the total fuel weight used for the flight.

The total fuel calculations for the example flight plan are shown below.

(1) Total Fuel Required
(c)(5) plus (d)(3) plus (e)(7), (2.8 gal. plus 3.0 gal. plus 9.1 gal.) 14.9 gal.
(14.9 gal. multiplied by 6 lb/gal.) 89 lbs.

THIS PAGE INTENTIONALLY LEFT BLANK

THIS PAGE INTENTIONALLY LEFT BLANK

5.7 PERFORMANCE GRAPHS

LIST OF FIGURES

Figure No.		Page No.
5-1	Airspeed System Calibration	5-11
5-3	Altimeter System Calibration	5-12
5-5	Stall Speeds	5-13
5-7	25° Flaps Takeoff Performance	5-14
5-8	25° Flaps Takeoff Ground Roll	5-14a
5-9	Flaps Up Takeoff Performance	5-14b
5-10	Flaps Up Takeoff Ground Roll	5-15
5-11	Gear Up Rate of Climb	5-16
5-13	Gear Down Rate of Climb	5-17
5-15	Fuel, Distance and Time to Climb	5-18
5-17	Power Setting Table	5-19
5-19	Speed Power - Performance Cruise	5-21
5-21	Speed Power - Economy Cruise	5-22
5-23	Range	5-23
5-24	Endurance	5-24
5-27	Fuel, Distance and Time to Descend	5-25
5-29	Glide Range	5-26
5-31	Landing Performance	5-27
5-33	Landing Ground Roll	5-28
5-35	Landing Performance (Heavy Duty Group)	5-29
5-37	Landing Ground Roll (Heavy Duty Group)	5-30

THIS PAGE INTENTIONALLY LEFT BLANK

PA-32R-300

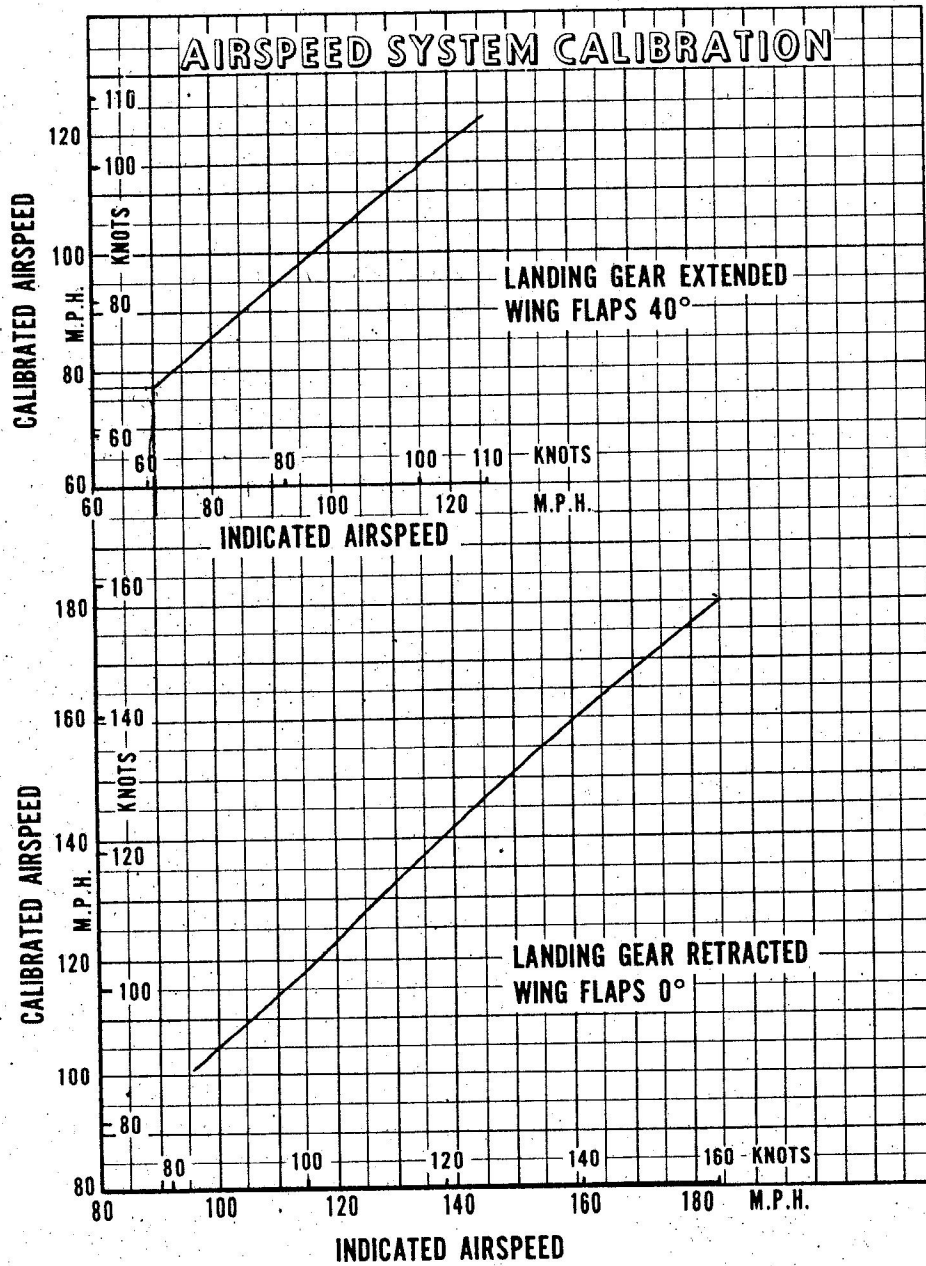

AIRSPEED SYSTEM CALIBRATION

Figure 5-1

PA-32R-300

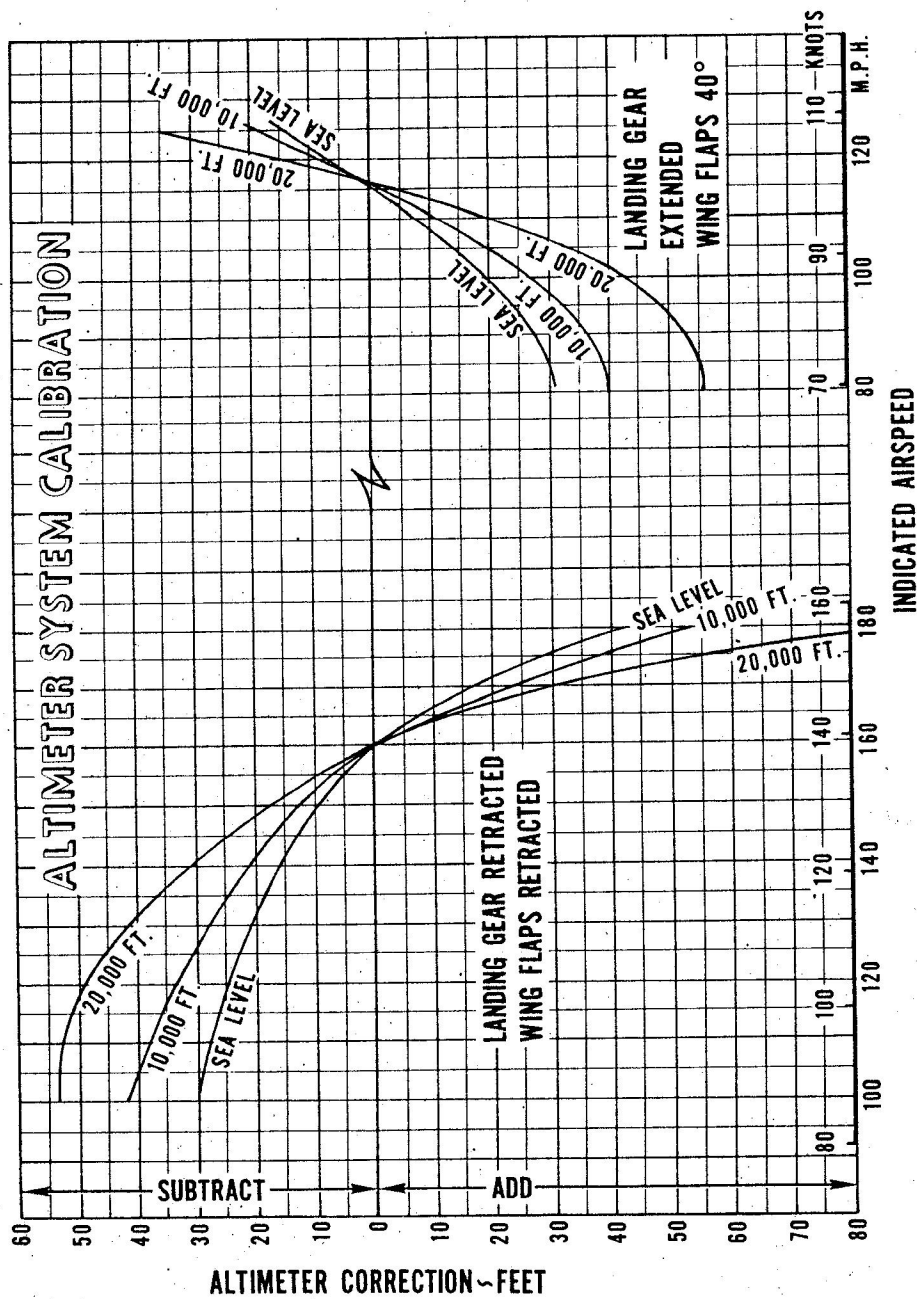

ALTIMETER CALIBRATION

Figure 5-3

PA-32R-300

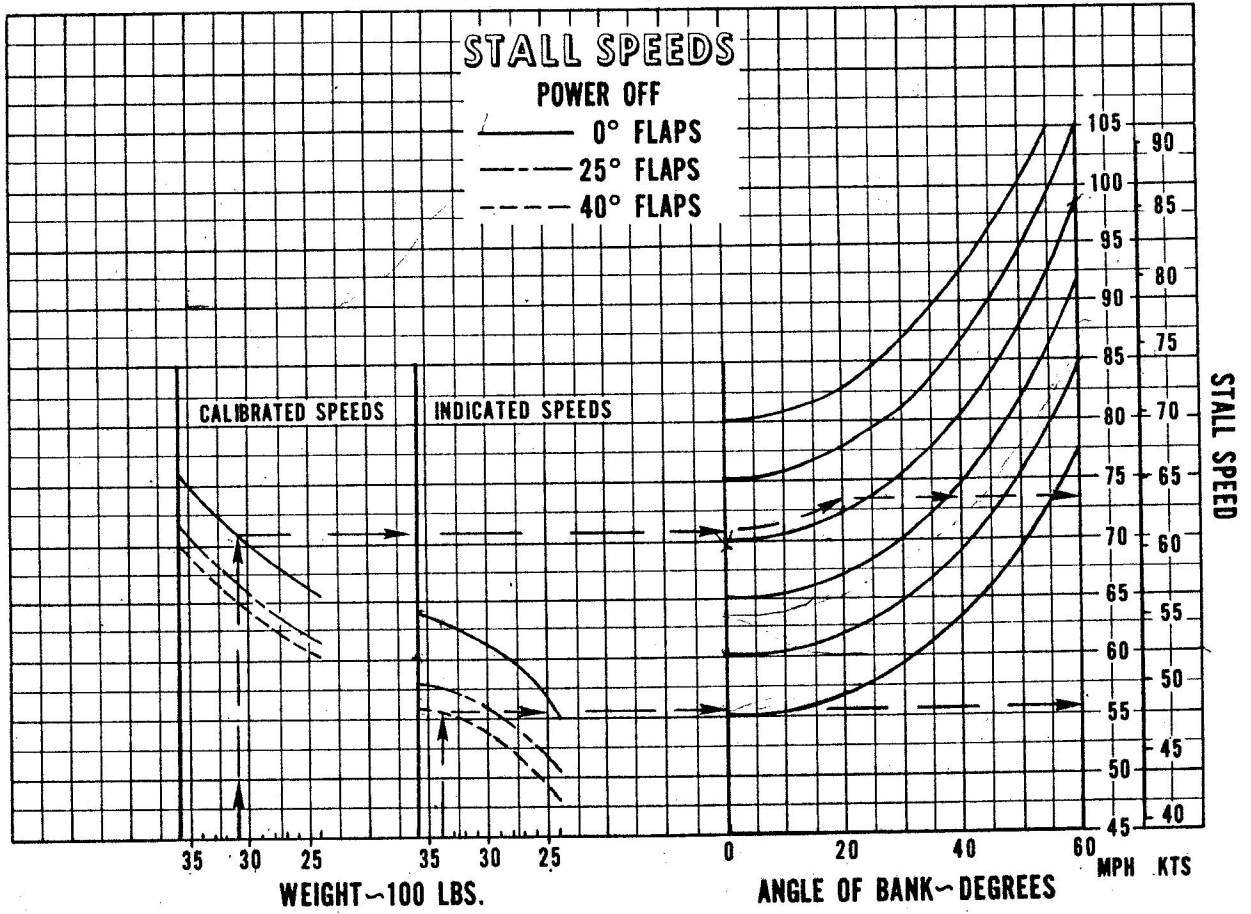

STALL SPEEDS

Figure 5-5

PA-32R-300

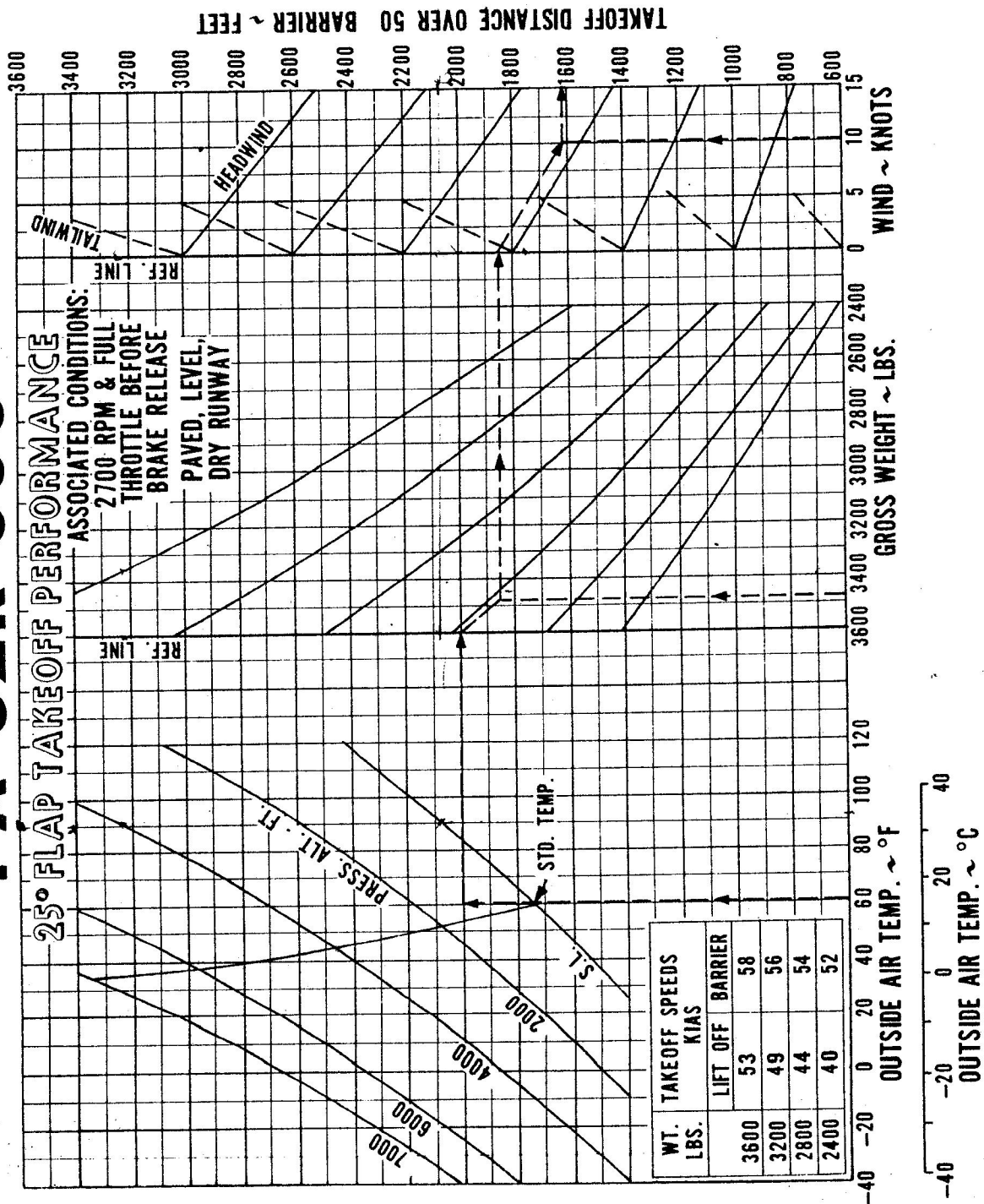

25° FLAPS TAKEOFF PERFORMANCE

Figure 5-7

PA-32R-300

25° FLAPS TAKEOFF GROUND ROLL

WT. LBS.	TAKEOFF SPEED KIAS	
	LIFT OFF	
3600	53	
3200	49	
2800	44	
2400	40	

ASSOCIATED CONDITIONS:
 - 2700 RPM & FULL THROTTLE BEFORE BRAKE RELEASE
 - PAVED, LEVEL, DRY RUNWAY

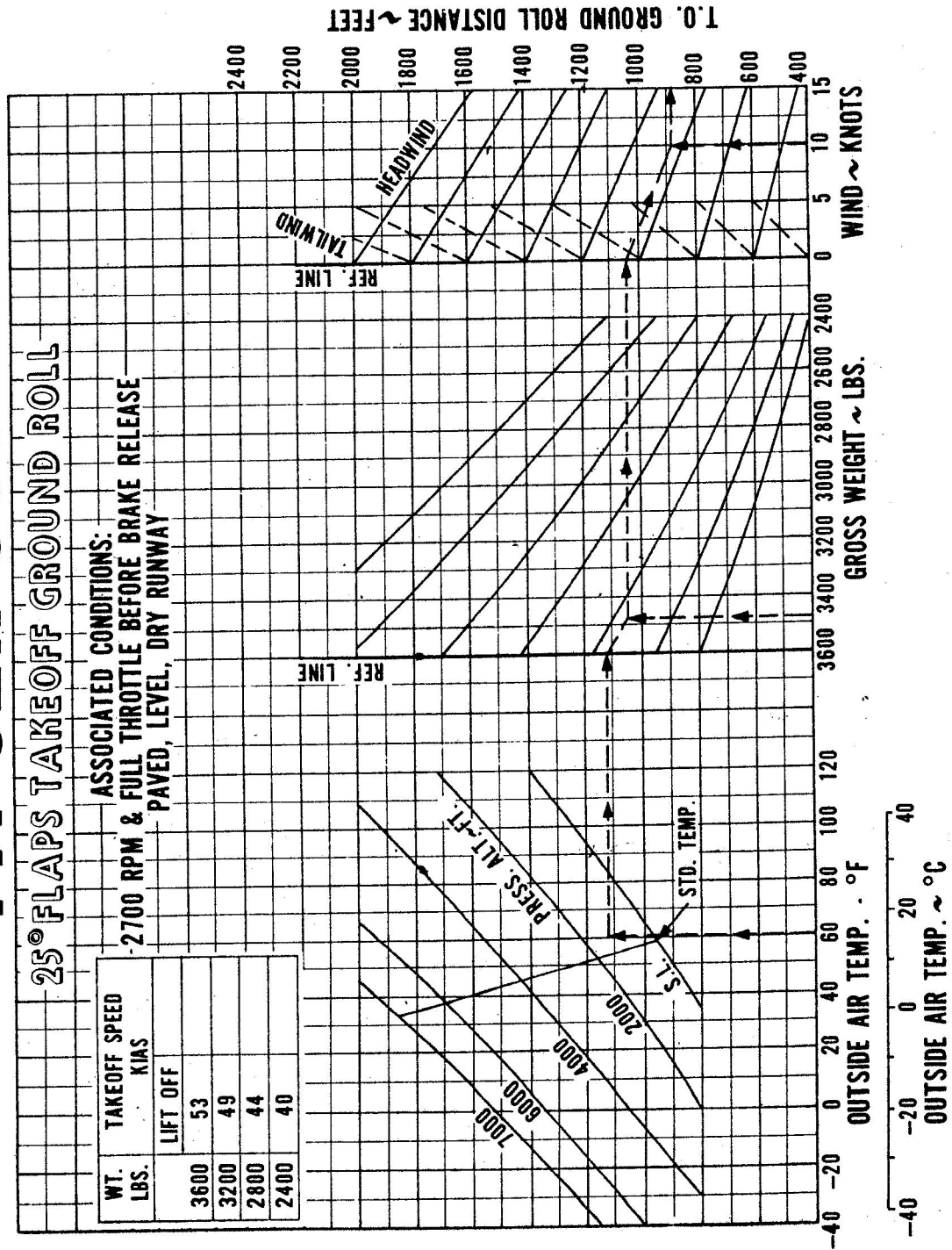

25° FLAPS TAKEOFF GROUND ROLL

Figure 5-8

PA-32R-300

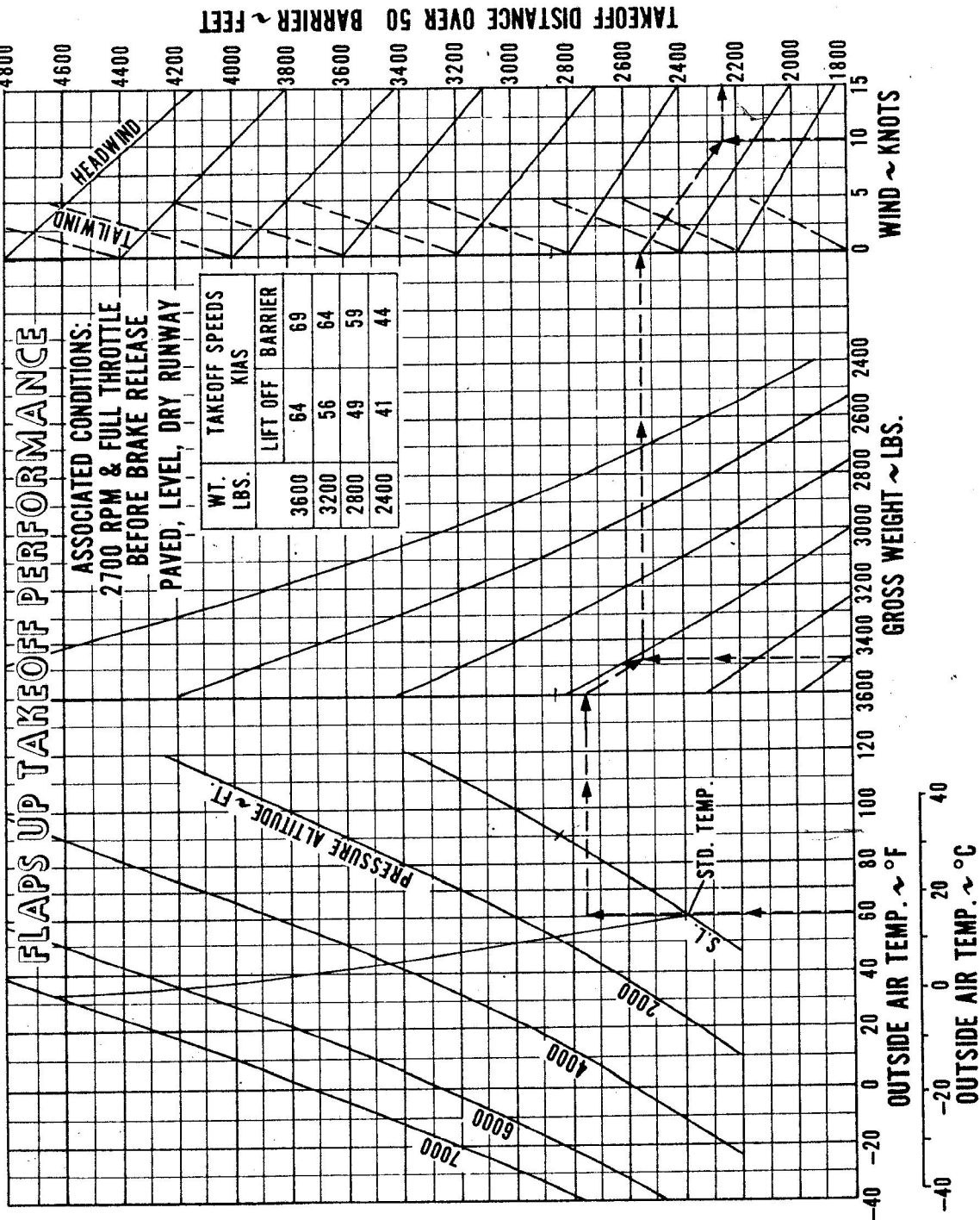

FLAPS UP TAKEOFF PERFORMANCE

Figure 5-9

PA-32R-300

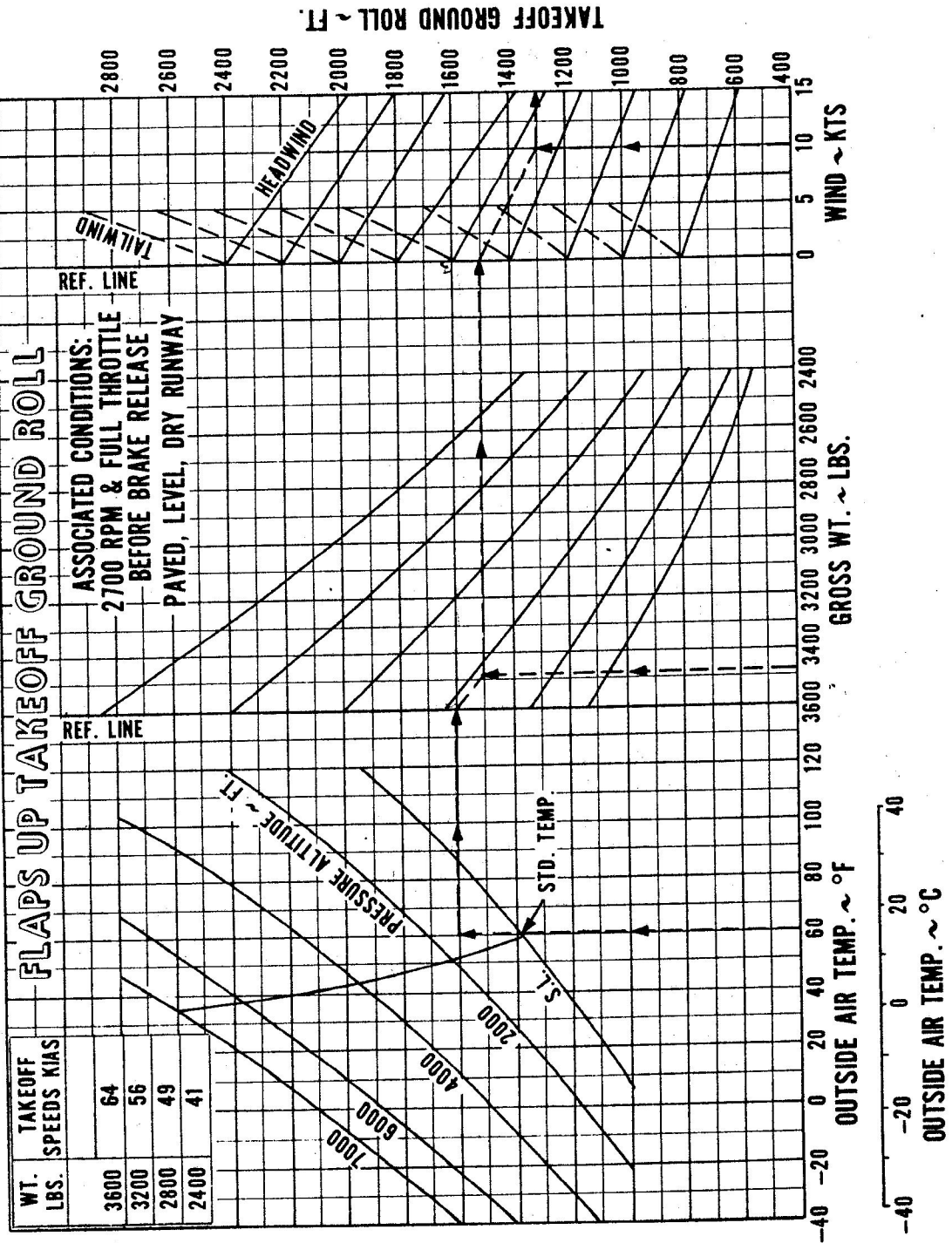

FLAPS UP TAKEOFF GROUND ROLL

Figure 5-10

PA-32R-300

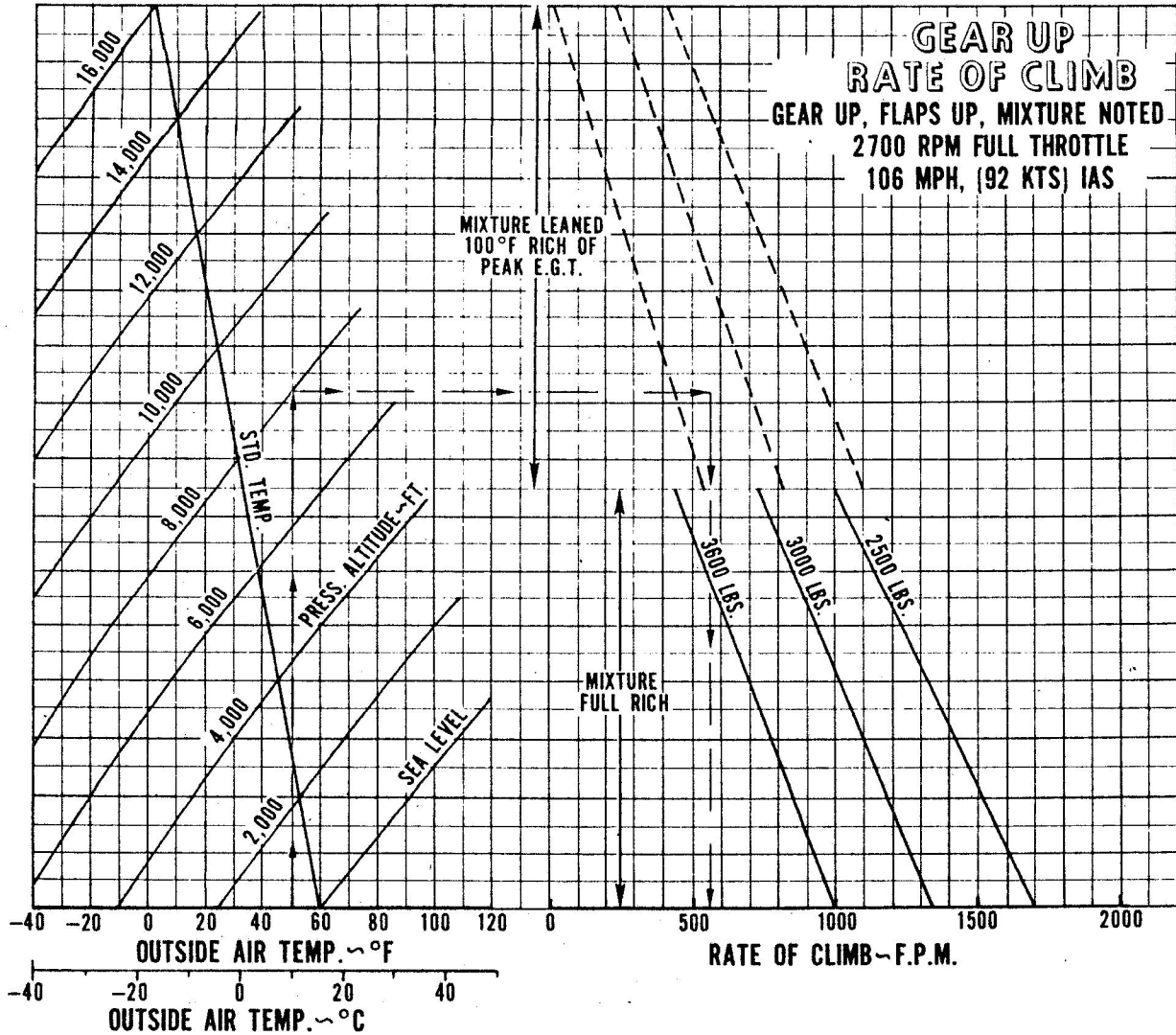

GEAR UP RATE OF CLIMB

Figure 5-11

PA-32R-300

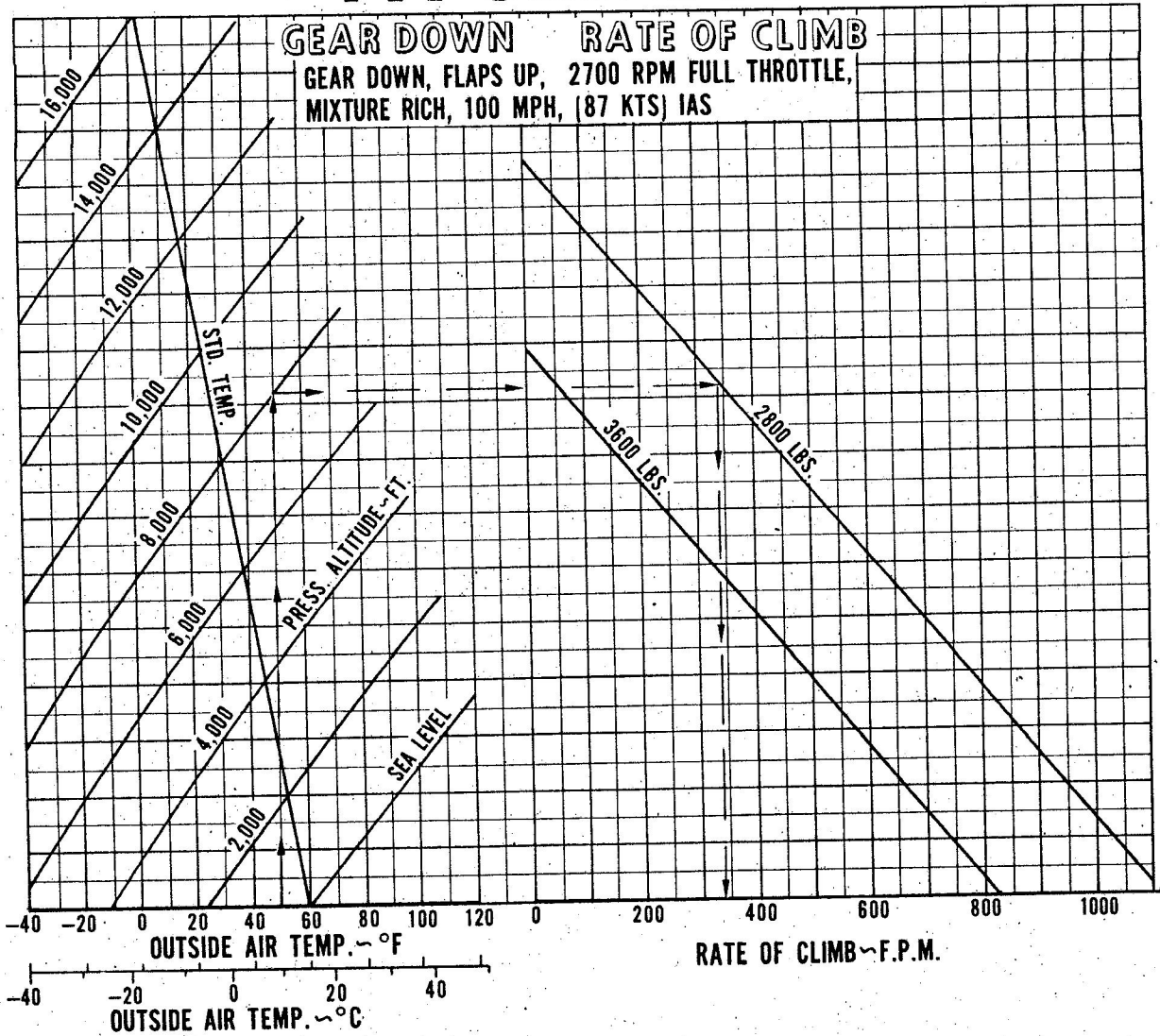

GEAR DOWN RATE OF CLIMB

Figure 5-13

PA-32R-300

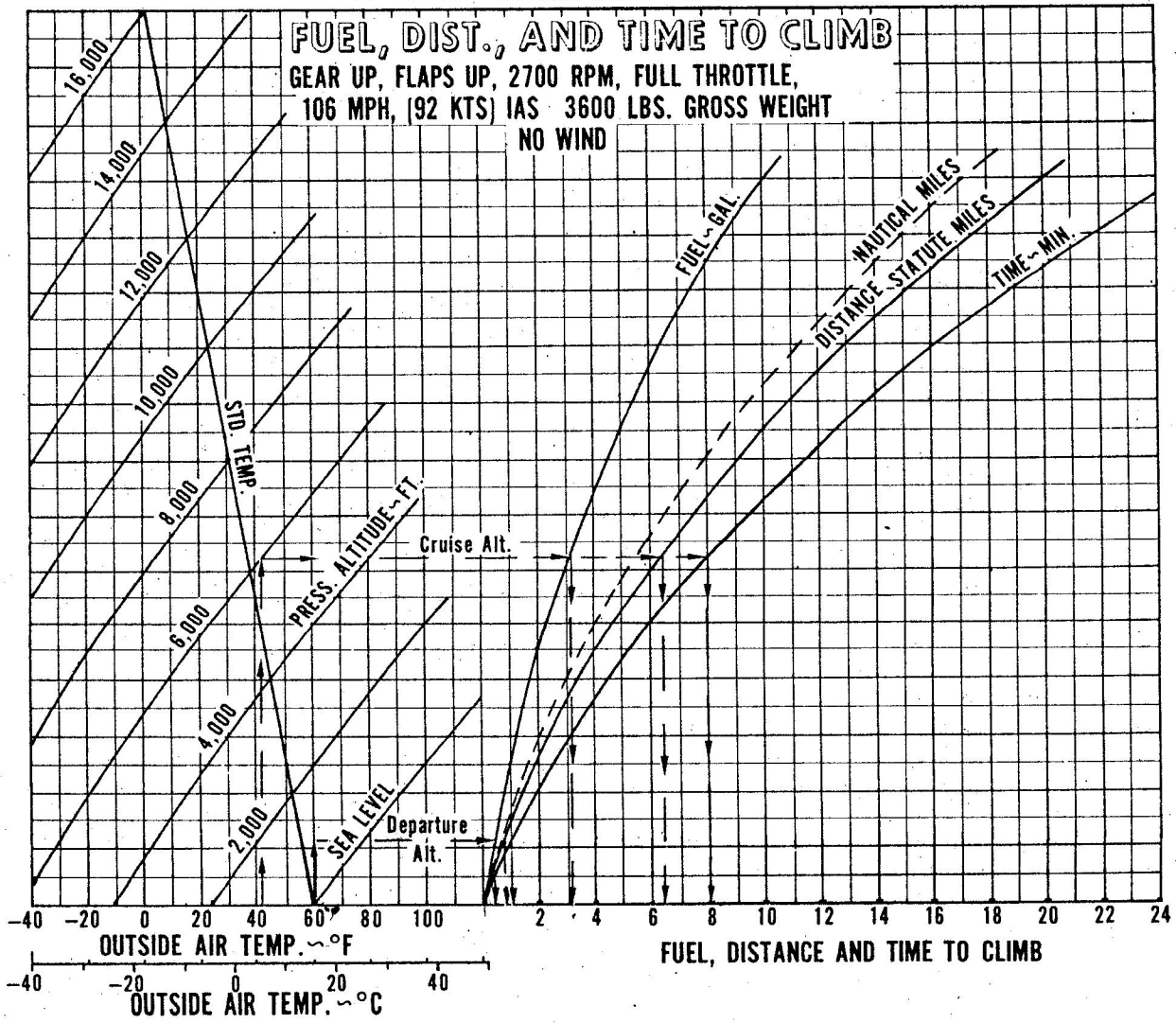

FUEL, DISTANCE AND TIME TO CLIMB

Figure 5-15

POWER SETTING TABLE - LYCOMING MODEL IO-540-K, -L, -M SERIES, 300 HP ENGINE

Press. Alt Feet	Std Alt Temp °F	135 HP - 45% RATED RPM AND MAN. PRESS.			165 HP - 55% RATED RPM AND MAN. PRESS.			195 HP - 65% RATED RPM AND MAN. PRESS.			225 HP - 75% RATED RPM AND MAN. PRESS.					
		2100	2200	2300	2400	2100	2200	2300	2400	2100	2200	2300	2400	2100	2200	2300
SL	59	19.0	18.5	18.0	17.6	22.5	21.8	21.2	20.7	25.6	24.7	23.8	23.2	27.6	26.6	25.8
1,000	55	18.8	18.3	17.8	17.4	22.3	21.6	21.0	20.5	25.3	24.4	23.5	22.9	27.3	26.3	25.5
2,000	52	18.6	18.1	17.6	17.2	22.1	21.4	20.7	20.2	25.1	24.2	23.3	22.7	27.1	26.1	25.2
3,000	48	18.4	17.9	17.4	17.0	21.9	21.2	20.5	20.0	24.8	23.9	23.0	22.5	26.8	25.8	24.9
4,000	45	18.25	17.75	17.2	16.8	21.7	21.0	20.3	19.8	24.6	23.7	22.8	22.2	26.5	25.6	24.6
5,000	41	18.1	17.6	17.0	16.6	21.5	20.8	20.1	19.6	24.3	23.5	22.5	22.0	26.3	25.3	24.4
6,000	38	17.9	17.4	16.8	16.4	21.3	20.6	19.8	19.3	24.0	23.2	22.3	21.7	26.1	25.0	24.1
7,000	34	17.7	17.2	16.6	16.25	21.0	20.4	19.6	19.1	23.7	22.9	22.0	21.5	25.9	24.8	23.8
8,000	31	17.5	17.0	16.5	16.1	20.8	20.2	19.4	18.9	23.5	22.7	21.8	21.2	25.7	24.6	23.6
9,000	27	17.3	16.8	16.3	15.9	20.6	20.0	19.2	18.6	23.3	22.5	21.5	21.0	25.5	24.4	23.4
10,000	23	17.1	16.6	16.1	15.75	20.4	19.8	19.0	18.4	23.1	22.3	21.2	20.7	25.3	24.2	23.2
11,000	19	16.9	16.4	15.9	15.6	20.2	19.6	18.7	18.2	22.9	22.1	21.0	20.4	25.1	24.0	23.0
12,000	16	16.75	16.25	15.75	15.4	20.0	19.4	18.5	18.0	22.7	21.9	20.8	20.2	24.9	23.8	22.8
13,000	12	16.6	16.0	15.6	15.2	19.8	19.2	18.3	17.7	22.5	21.7	20.6	20.0	24.7	23.6	22.6
14,000	9	16.4	15.8	15.4	15.0	19.6	19.0	18.0	17.3	22.3	21.5	20.4	19.8	24.5	23.4	22.4
15,000	5	16.2	15.7	15.2	14.8	19.4	18.8	17.8	17.1	22.1	21.3	20.2	19.6	24.3	23.2	22.2

POWER SETTING TABLE

Figure 5-17

To maintain constant power, correct manifold pressure approximately 0.18" Hg for each 10°F variation in induction air temperature from standard altitude temperature. Add manifold pressure for air temperature above standard; subtract for temperature below standard.

THIS PAGE INTENTIONALLY LEFT BLANK

PA-32R-300

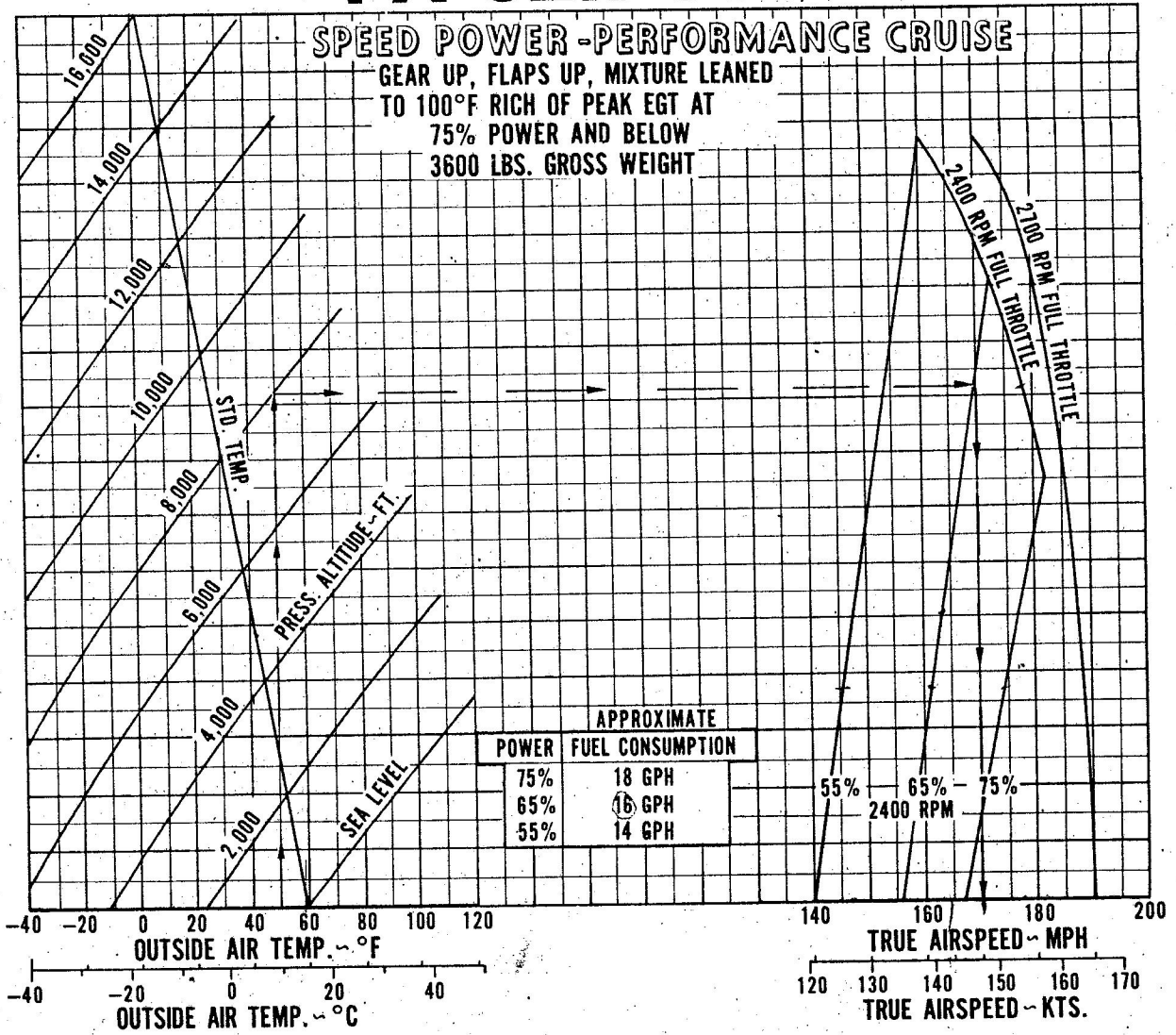

SPEED POWER - PERFORMANCE CRUISE

Figure 5-19

PA-32R-300

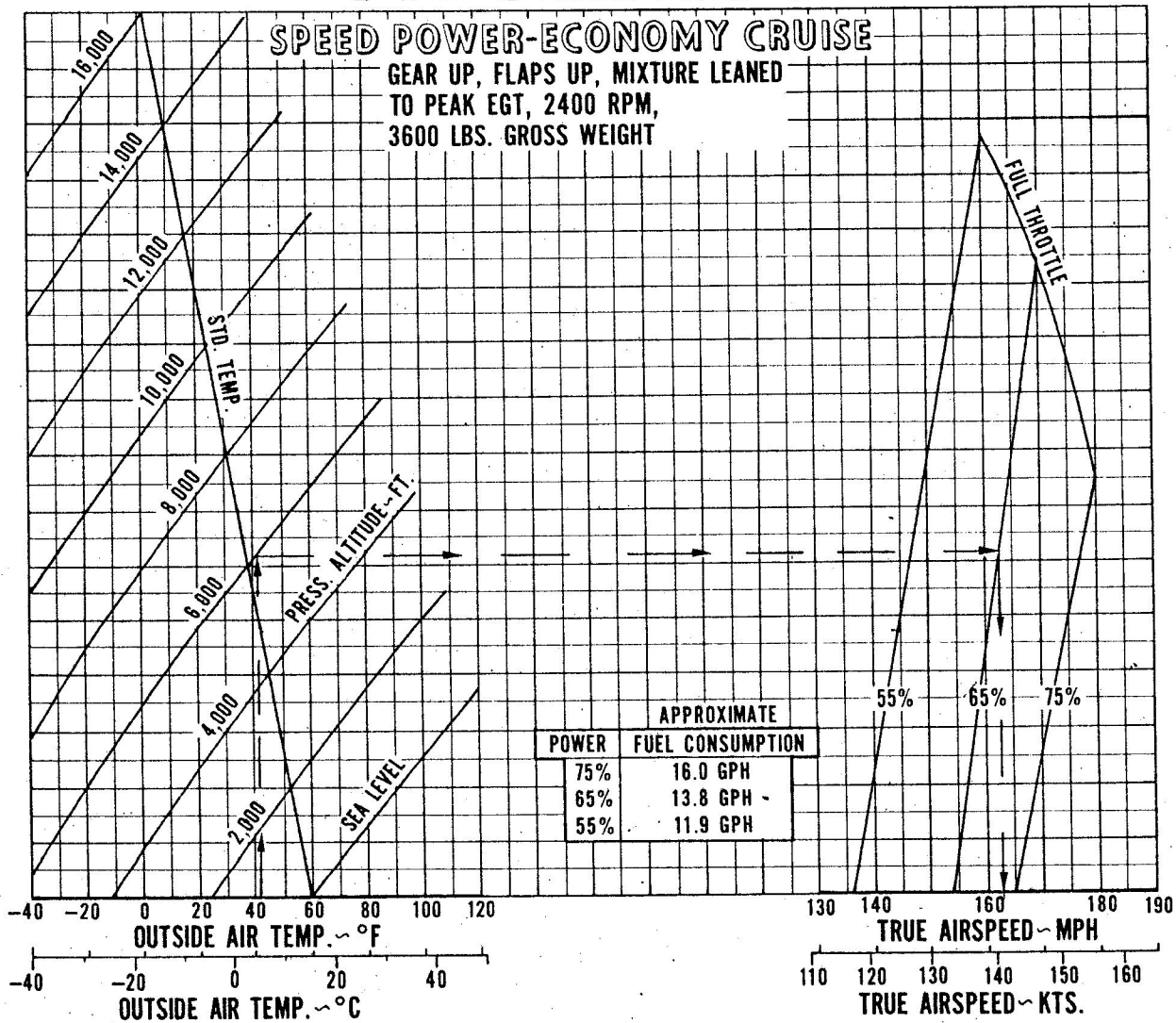

SPEED POWER - ECONOMY CRUISE

Figure 5-21

PA-32R-300

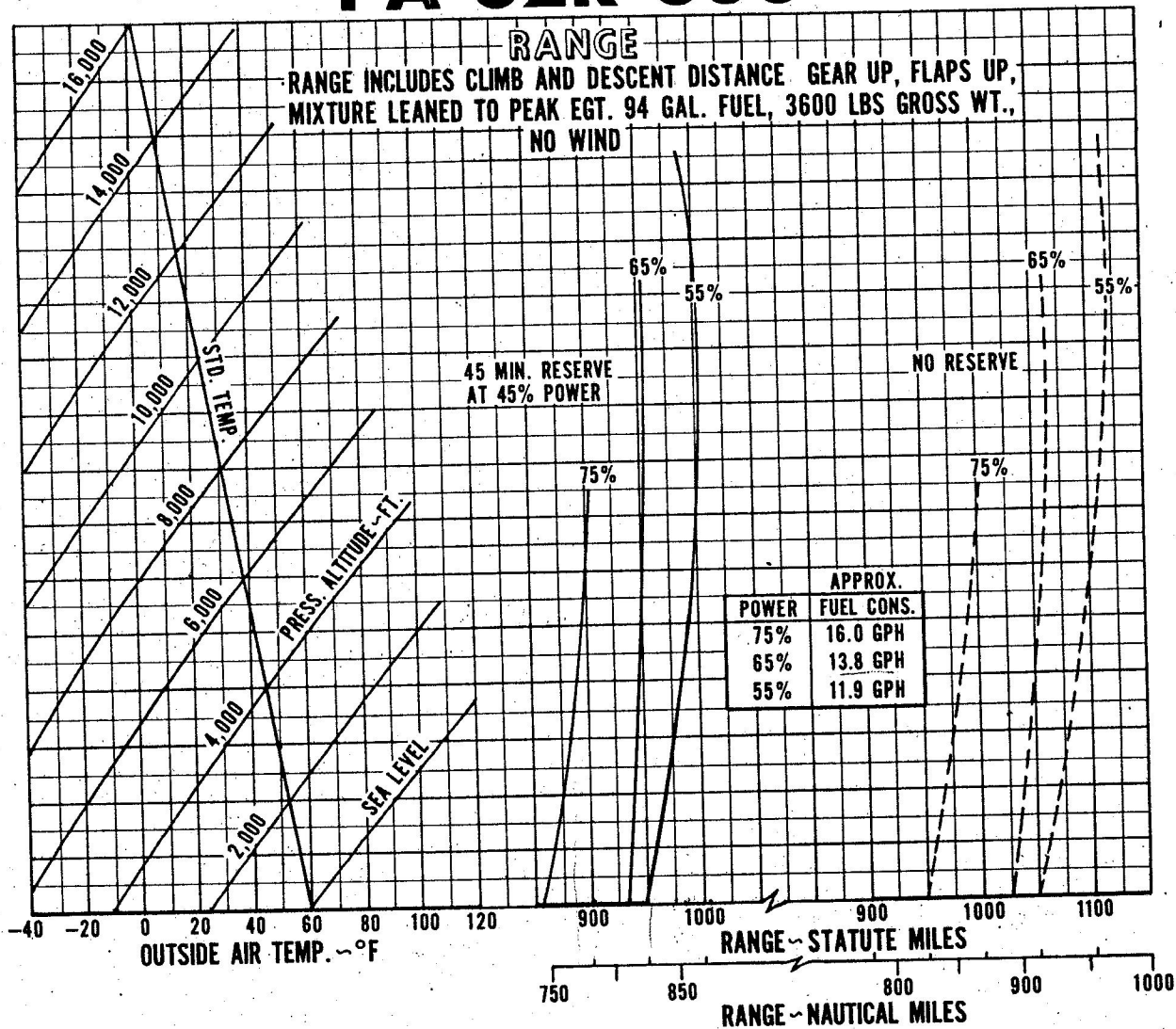

RANGE
Figure 5-23

PA-32R-300

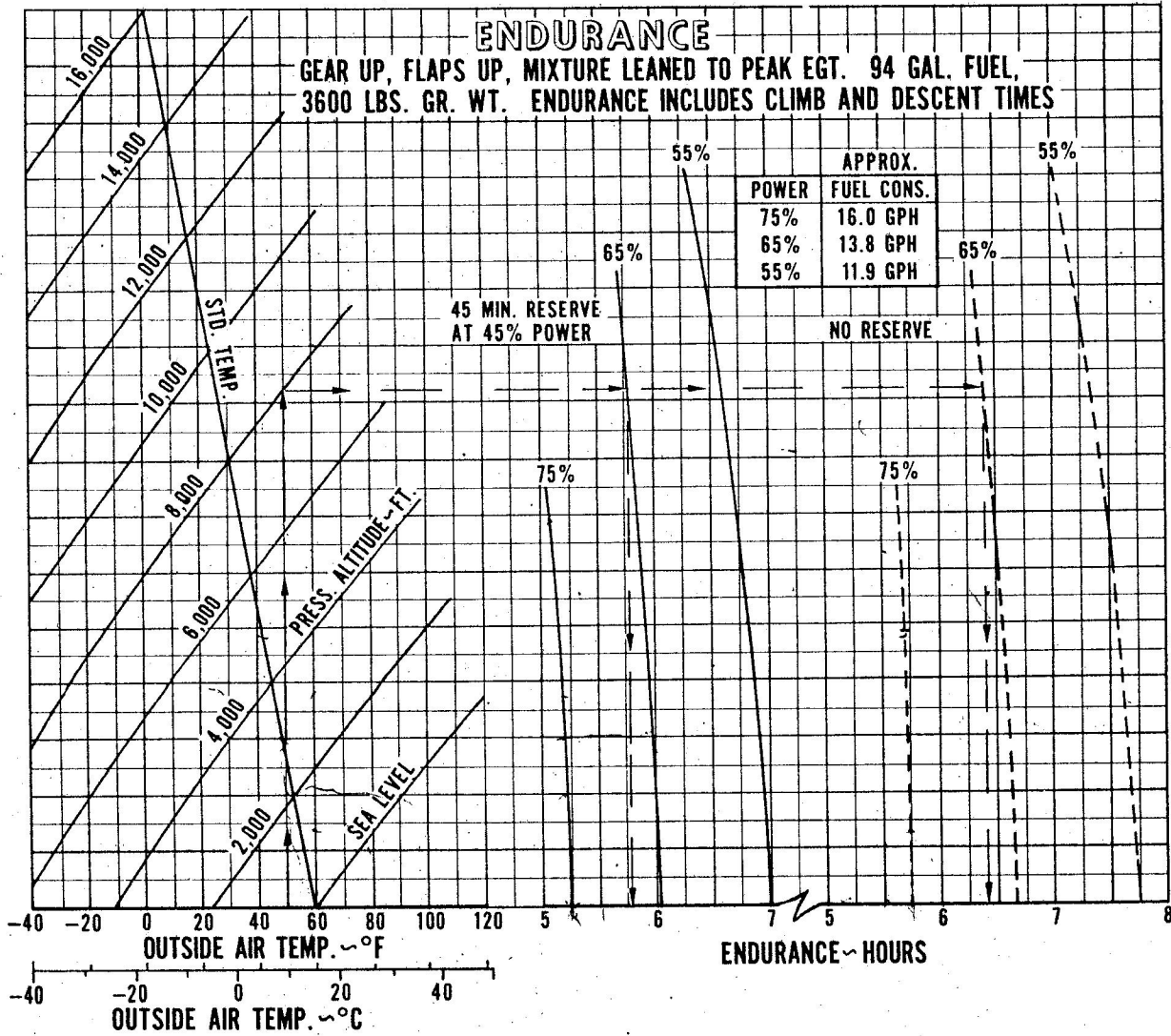

ENDURANCE

Figure 5-25

PA-32R-300

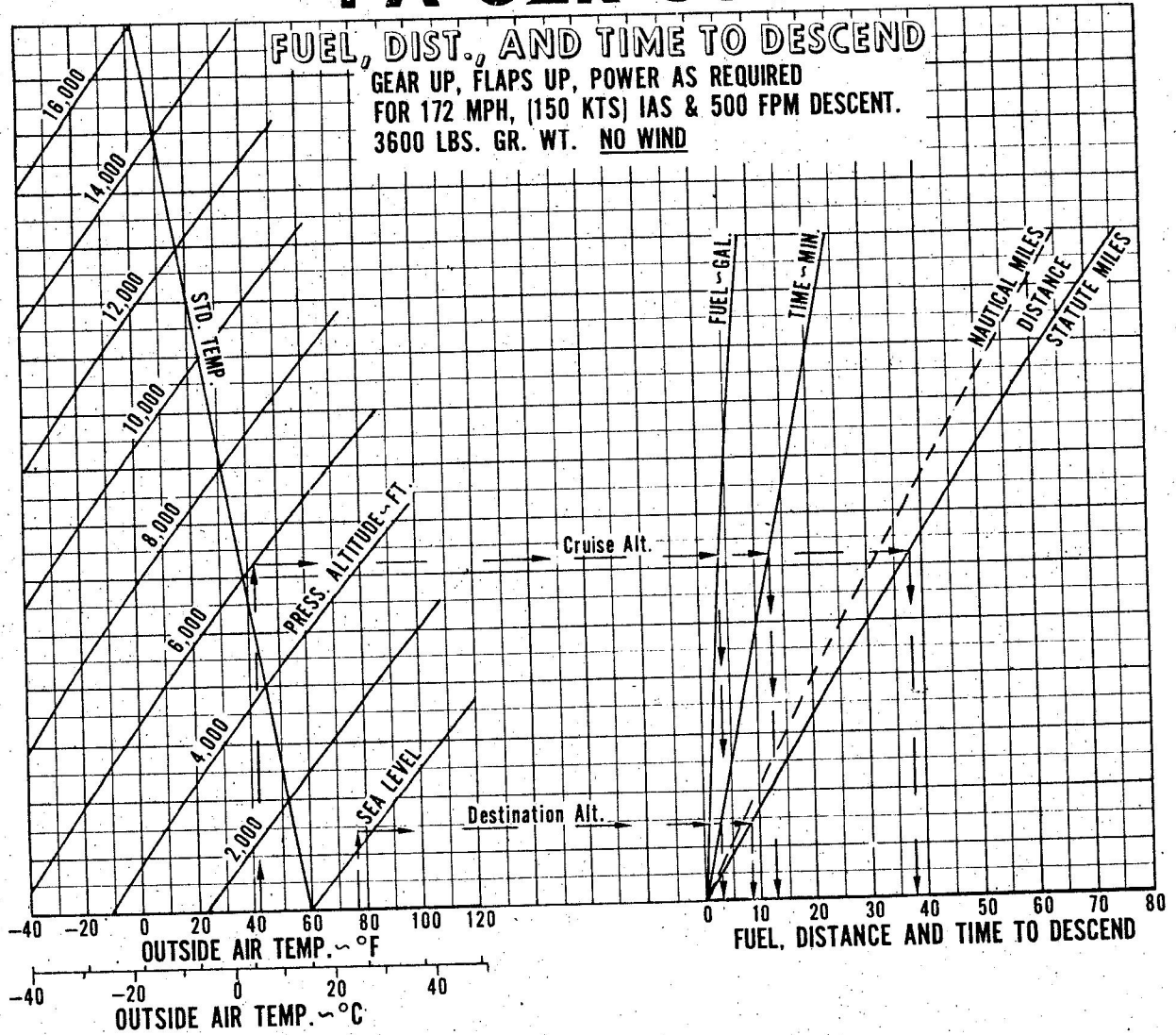

FUEL, DISTANCE AND TIME TO DESCEND

Figure 5-27

PA-32R-300

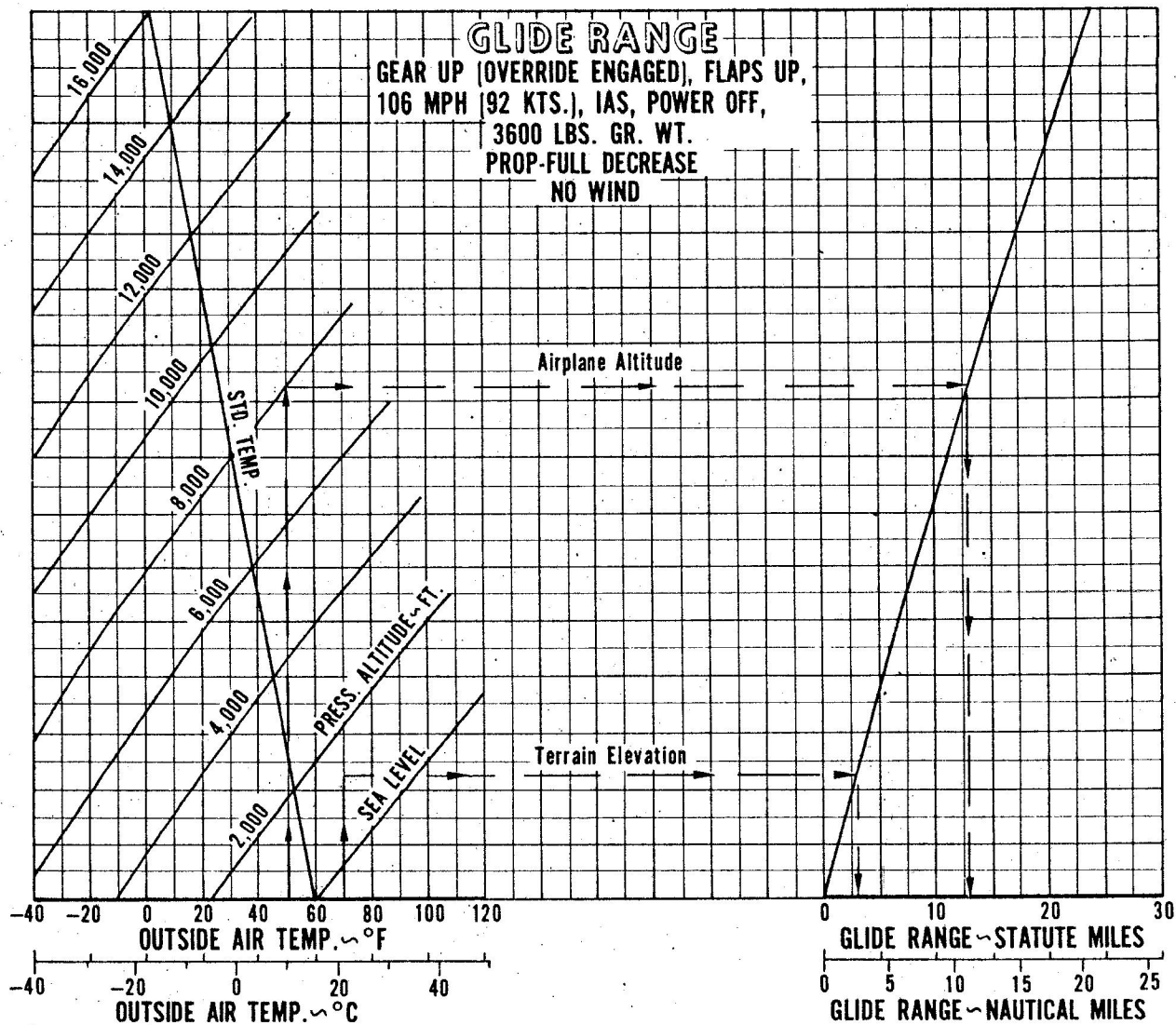

Example:

- Cruise altitude = 8000 ft.
- Terrain elevation = 1300 ft.
- Glide distance = 13 miles minus 3 miles equals 10 miles

GLIDE RANGE

Figure 5-29

PA-32R-300

LANDING PERFORMANCE

- ASSOCIATED CONDITIONS:
- STANDARD WHEELS, TIRES AND BRAKES
- POWER OFF APPROACH, 40° FLAPS
- LANDING GEAR EXTENDED, 75 KIAS APPROACH SPEED
- FULL STALL TOUCHDOWN, MAXIMUM BRAKING
- PAVED, LEVEL, DRY RUNWAY

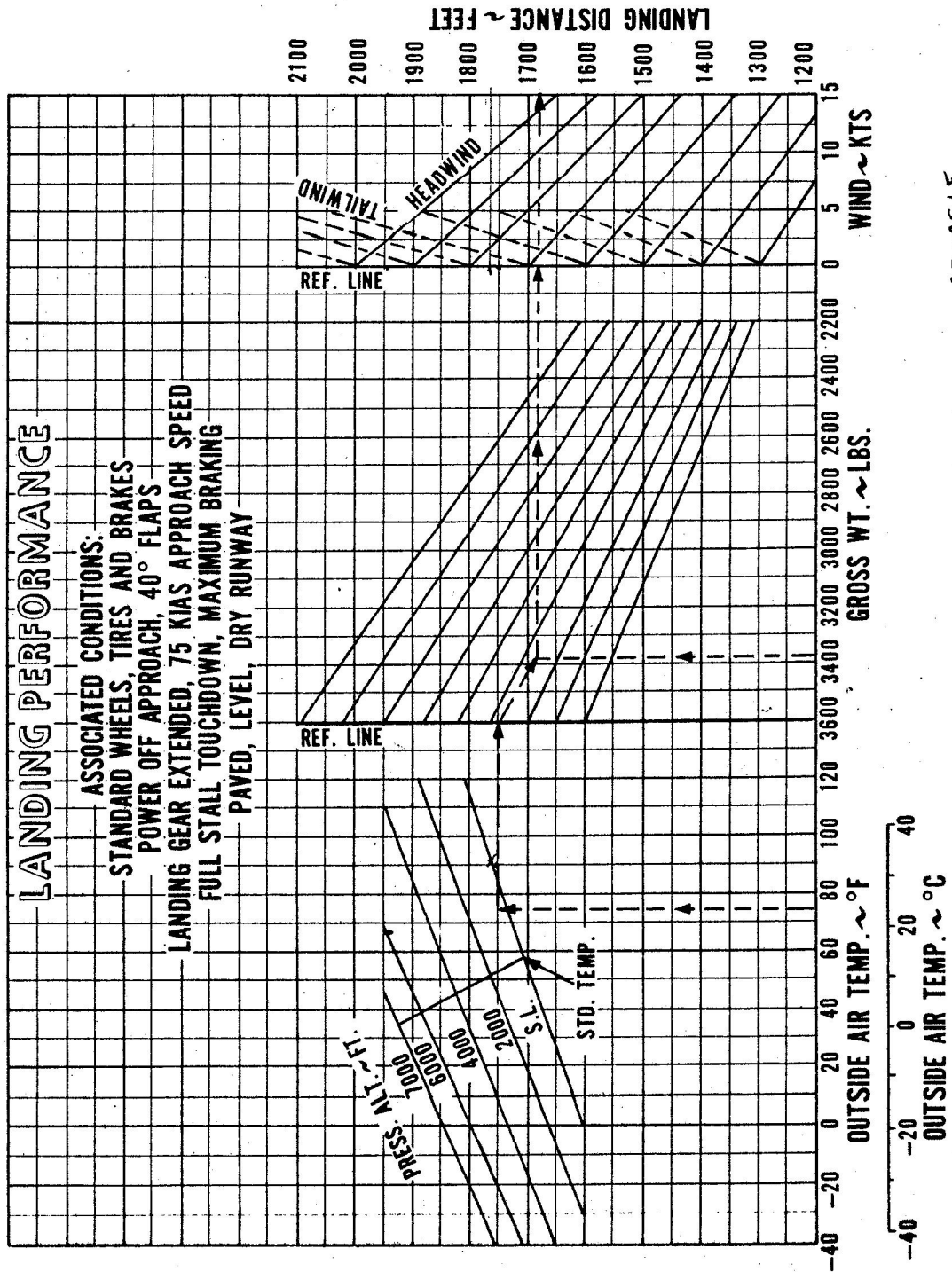

OVER OBSTACLE

LANDING PERFORMANCE

Figure 5-31

PA-32R-300

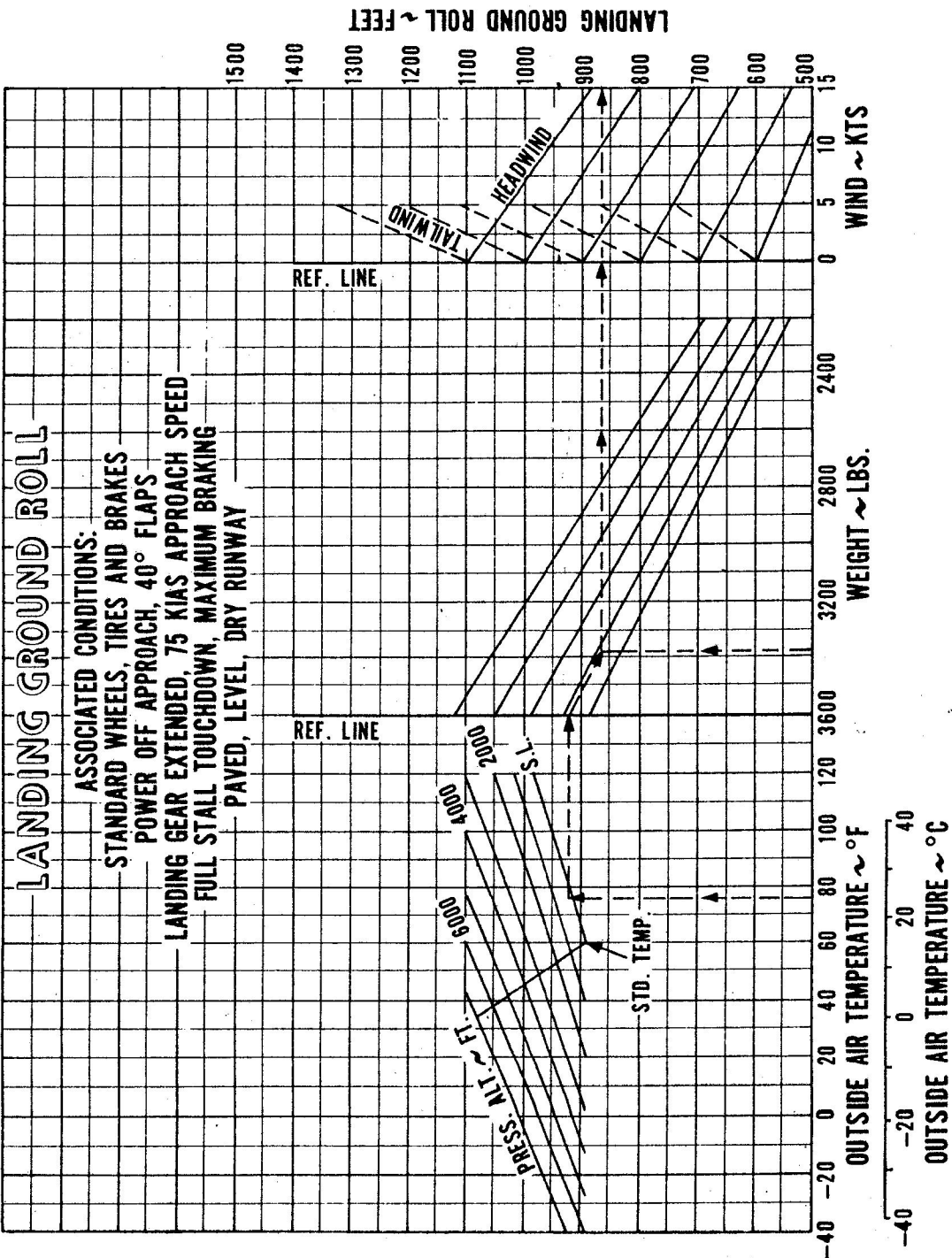

LANDING GROUND ROLL

Figure 5-33

PA-32R-300

LANDING PERFORMANCE

ASSOCIATED CONDITIONS:
WITH OPTIONAL LANDING GEAR
HEAVY DUTY GROUP NO.1 INSTALLED (See Equipment List)
POWER OFF APPROACH, 40° FLAPS
LANDING GEAR EXTENDED, FULL STALL TOUCHDOWN
MAXIMUM BRAKING, PAVED, LEVEL, DRY RUNWAY

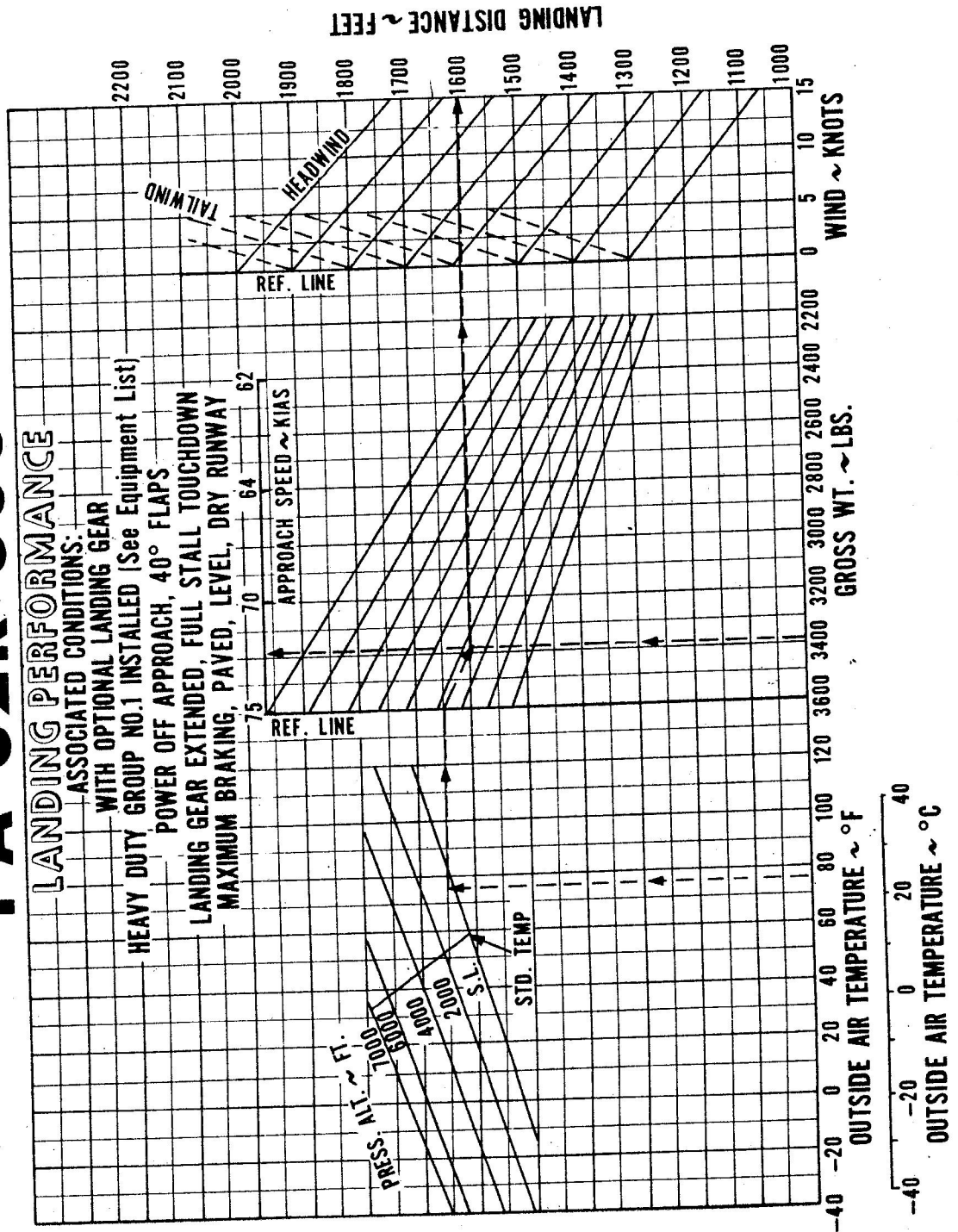

LANDING PERFORMANCE (HEAVY DUTY GROUP)

Figure 5-35

PA-32R-300

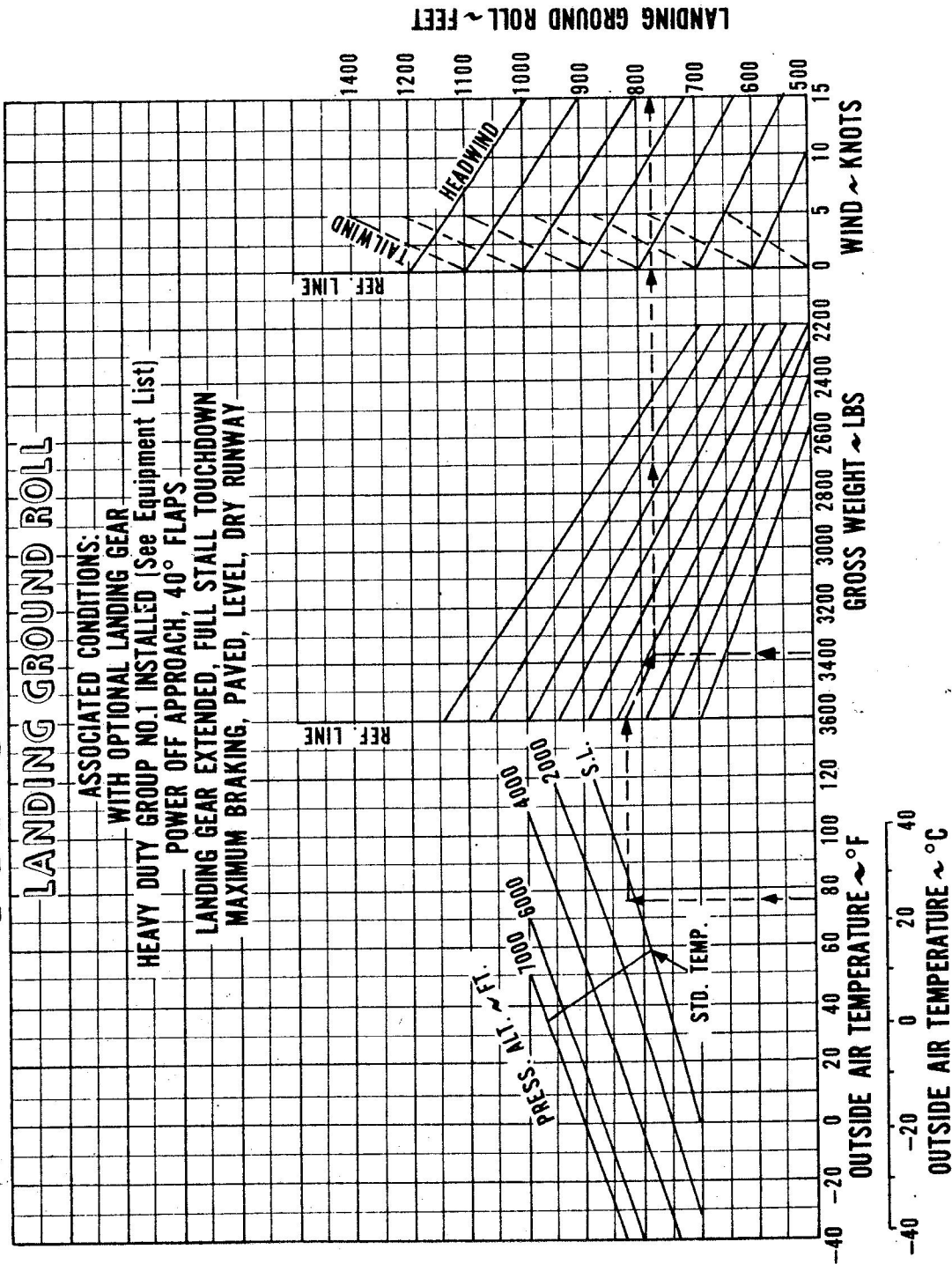

LANDING GROUND ROLL (HEAVY DUTY GROUP)

Figure 5-37

TABLE OF CONTENTS

SECTION 6

WEIGHT AND BALANCE

Paragraph No.		Page No.
6.1	General	6-1
6.3	Airplane Weighing Procedure	6-3
6.5	Weight and Balance Data and Record	6-6
6.7	Weight and Balance Determination for Flight	6-11
6.9	Equipment List	6-17
(a)	Propeller and Propeller Accessories	6-17
(b)	Engine and Engine Accessories	6-19
(c)	Landing Gear and Brakes	6-21
(d)	Electrical Equipment	6-23
(e)	Instruments	6-25
(f)	Miscellaneous	6-27
(g)	Engine and Engine Accessories (Optional Equipment)	6-29
(h)	Propeller and Propeller Accessories (Optional Equipment)	6-31
(i)	Landing Gear and Brakes (Optional Equipment)	6-33
(j)	Electrical Equipment (Optional Equipment)	6-35
(k)	Instruments (Optional Equipment)	6-37
(l)	Autopilots (Optional Equipment)	6-39
(m)	Radio Equipment (Optional Equipment)	6-41
(n)	Miscellaneous (Optional Equipment)	6-49

**SECTION 6
WEIGHT AND BALANCE**

6.1 GENERAL

In order to achieve the performance and flying characteristics which are designed into the airplane, it must be flown with the weight and center of gravity (C.G.) position within the approved operating range (envelope). Although the airplane offers flexibility of loading, it cannot be flown with the maximum number of adult passengers, full fuel tanks and maximum baggage. With the flexibility comes responsibility. The pilot must ensure that the airplane is loaded within the loading envelope before he makes a takeoff.

Misloading carries consequences for any aircraft. An overloaded airplane will not take off, climb or cruise as well as a properly loaded one. The heavier the airplane is loaded, the less climb performance it will have.

Center of gravity is a determining factor in flight characteristics. If the C.G. is too far forward in any airplane, it may be difficult to rotate for takeoff or landing. If the C.G. is too far aft, the airplane may rotate prematurely on takeoff or tend to pitch up during climb. Longitudinal stability will be reduced. This can lead to inadvertent stalls and even spins; and spin recovery becomes more difficult as the center of gravity moves aft of the approved limit.

A properly loaded airplane, however, will perform as intended. Before the airplane is licensed, it is weighed, and a basic empty weight and C.G. location is computed (basic empty weight consists of the standard empty weight of the airplane plus the optional equipment). Using the basic empty weight and C.G. location, the pilot can easily determine the weight and C.G. position for the loaded airplane by computing the total weight and moment and then determining whether they are within the approved envelope.

The basic empty weight and C.G. location are recorded in the Weight and Balance Data Form (Figure 6-5) and the Weight and Balance Record (Figure 6-7). The current values should always be used. Whenever new equipment is added or any modification work is done, the mechanic responsible for the work is required to compute a new basic empty weight and C.G. position and to write these in the Aircraft Log Book and the Weight and Balance Record. The owner should make sure that it is done.

A weight and balance calculation is necessary in determining how much fuel or cargo can be boarded so as to keep within allowable limits. Check calculations prior to adding fuel to insure against improper loading.

The following pages are forms used in weighing an airplane in production and in computing basic empty weight, C.G. position, and useful load. Note that the useful load includes usable fuel, baggage, cargo and passengers. Following this is the method for computing takeoff weight and C.G.

THIS PAGE INTENTIONALLY LEFT BLANK

6.3 AIRPLANE WEIGHING PROCEDURE

At the time of licensing, Piper Aircraft Corporation provides each airplane with the basic empty weight and center of gravity location. This data is supplied by Figure 6-5.

The removal or addition of equipment or airplane modifications can affect the basic empty weight and center of gravity. The following is a weighing procedure to determine this basic empty weight and center of gravity location:

(a) Preparation

- (1) Be certain that all items checked in the airplane equipment list are installed in the proper location in the airplane.
- (2) Remove excessive dirt, grease, moisture, foreign items such as rags and tools from the airplane before weighing.
- (3) Defuel airplane. Then open all fuel drains until all remaining fuel is drained. Operate engine on each tank until all undrainable fuel is used and engine stops. Then add the unusable fuel (4.0 gallons total, 2.0 gallons each wing).

CAUTION

Whenever the fuel system is completely drained and fuel is replenished it will be necessary to run the engine for a minimum of 3 minutes at 1000 RPM on each tank to insure that no air exists in the fuel lines.

- (4) Fill with oil to full capacity.
 - (5) Place pilot and copilot seats in fourth (4th) notch, aft of forward position. Put flaps in the fully retracted position and all control surfaces in the neutral position. Tow bar should be in the proper location and all entrance and baggage doors closed.
 - (6) Weigh the airplane inside a closed building to prevent errors in scale readings due to wind.
- (b) Leveling
- (1) With airplane on scales, block main gear oleo pistons in the fully extended position.
 - (2) Level airplane (refer to Figure 6-3) deflating nose wheel tire, to center bubble on level.

(c) Weighing - Airplane Basic Empty Weight

- (1) With the airplane level and brakes released, record the weight shown on each scale. Deduct the tare, if any, from each reading.

Scale Position and Symbol	Scale Reading	Tare	Net Weight
Nose Wheel (N)			
Right Main Wheel (R)			
Left Main Wheel (L)			
Basic Empty Weight, as Weighed (T)	— —	— —	

WEIGHING FORM

Figure 6-1

(d) Basic Empty Weight Center of Gravity

- (1) The following geometry applies to the PA-32R-300 airplane when it is level. Refer to Leveling paragraph 6.3 (b).

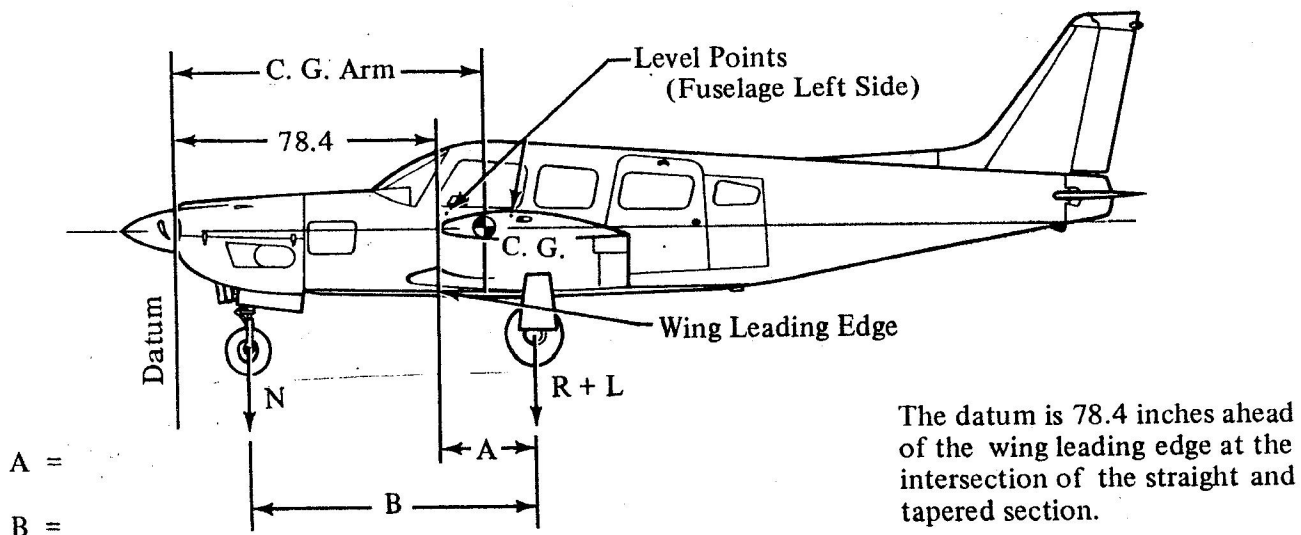

LEVELING DIAGRAM

Figure 6-3

- (2) Obtain measurement "A" by measuring from a plumb bob dropped from the wing leading edge, at the intersection of the straight and tapered section, horizontally and parallel to the airplane centerline, to the main wheel centerline.
- (3) Obtain measurement "B" by measuring the distance from the main wheel centerline, horizontally and parallel to the airplane centerline, to each side of the nose wheel axle. Then average the measurements.
- (4) The basic empty weight center of gravity (as weighed including optional equipment, full oil and unusable fuel) can be determined by the following formula:

$$\text{C.G. Arm} = 78.4 + A - \frac{B(N)}{T}$$

$$\text{C.G. Arm} = 78.4 + (\quad) - \frac{(\quad) (\quad)}{(\quad)} = \quad \text{inches}$$

6.5 WEIGHT AND BALANCE DATA AND RECORD

The Basic Empty Weight, Center of Gravity Location and Useful Load listed in Figure 6-5 are for the airplane as licensed at the factory. These figures apply only to the specific airplane serial number and registration number shown.

The basic empty weight of the airplane as licensed at the factory has been entered in the Weight and Balance Record (Figure 6-7). This form is provided to present the current status of the airplane basic empty weight and a complete history of previous modifications. Any change to the permanently installed equipment or modification which affects weight or moment must be entered in the Weight and Balance Record.

MODEL PA-32R-300 CHEROKEE LANCE

Airplane Serial Number _____

Registration Number _____

Date _____

AIRPLANE BASIC EMPTY WEIGHT

Item	Weight (Lbs)	x	C. G. Arm (Inches Aft of Datum)	=	Moment (In-Lbs)
Standard Empty Weight*					
Optional Equipment					
Basic Empty Weight					

*The standard empty weight includes full oil capacity and 4.0 gallons of unusable fuel.

AIRPLANE USEFUL LOAD - NORMAL CATEGORY OPERATION

(Gross Weight) - (Basic Empty Weight) = Useful Load

(3600 lbs) - (lbs) = lbs.

THIS BASIC EMPTY WEIGHT, C.G. AND USEFUL LOAD ARE FOR THE AIRPLANE AS LICENSED AT THE FACTORY. REFER TO APPROPRIATE AIRCRAFT RECORD WHEN ALTERATIONS HAVE BEEN MADE.

WEIGHT AND BALANCE DATA FORM

Figure 6-5

THIS PAGE INTENTIONALLY LEFT BLANK

6.7 WEIGHT AND BALANCE DETERMINATION FOR FLIGHT

- (a) Add the weight of all items to be loaded to the basic empty weight.
- (b) Use the Loading Graph (Figure 6-13) to determine the moment of all items to be carried in the airplane.
- (c) Add the moment of all items to be loaded to the basic empty weight moment.
- (d) Divide the total moment by the total weight to determine the C.G. location.
- (e) By using the figures of item (a) and item (d) (above), locate a point on the C.G. range and weight graph (Figure 6-15). If the point falls within the C.G. envelope, the loading meets the weight and balance requirements.

	Weight (Lbs)	Arm Aft Datum (Inches)	Moment (In-Lbs)
Basic Empty Weight	2118 ^{2127.2}	81.3 ^{81.9}	172288 ¹⁷⁴²¹⁷
Pilot and Front Passenger	340.0	85.5	29070
Passengers (Center Seats)	340.0	118.1	40154
Passengers (Rear Seats)	340.0	155.7	52938
Passenger (Jump Seat) (Optional)		118.1	
Fuel (94 Gallon Maximum)	361.9	93.6	33874
Baggage (Forward)	100	42.0	4200
Baggage (Aft)		178.7	
Moment due to Retraction of Landing Gear			819
Total Loaded Airplane	3600	92.6	333343

The center of gravity (C.G.) of this sample loading problem is at 92.6 inches aft of the datum line. Locate this point (92.6) on the C.G. range and weight graph. Since this point falls within the weight-C.G. envelope, this loading meets the weight and balance requirements.

IT IS THE RESPONSIBILITY OF THE PILOT AND AIRCRAFT OWNER TO INSURE THAT THE AIRPLANE IS LOADED PROPERLY.

SAMPLE LOADING PROBLEM (NORMAL CATEGORY)

Figure 6-9

**SECTION 6
WEIGHT AND BALANCE**

**PIPER AIRCRAFT CORPORATION
PA-32R-300, CHEROKEE LANCE**

	Weight (Lbs)	Arm Aft Datum (Inches)	Moment (In-Lbs)
Basic Empty Weight	2132.1	81.8	174466
Pilot and Front Passenger		85.5	
Passengers (Center Seats)		118.1	
Passengers (Rear Seats)		155.7	
Passenger (Jump Seat) (Optional)		118.1	
Fuel (94 Gallon Maximum)		93.6	
Baggage (Forward)		42.0	
Baggage (Aft)		178.7	
Moment due to Retraction of Landing Gear			819
Total Loaded Airplane			

Totals must be within approved weight and C.G. limits. It is the responsibility of the airplane owner and the pilot to insure that the airplane is loaded properly. The Basic Empty Weight C.G. is noted on the Weight and Balance Data Form (Figure 6-5). If the airplane has been altered, refer to the Weight and Balance Record for this information.

WEIGHT AND BALANCE LOADING FORM

Figure 6-11

ISSUED: AUGUST 1, 1975

SECTION 6
WEIGHT AND BALANCE

PIPER AIRCRAFT CORPORATION
PA-32R-300, CHEROKEE LANCE

WITH CENTER SEATS & CONSOLE REMOVED

N4505X SN: 32R-7680022	Weight (Lbs)	Arm Aft Datum (Inches)	Moment (In-Lbs)
Basic Empty Weight	2194.00	80.14	175825.60
Pilot and Front Passenger	435	85.5	37192.50
Passengers (Center Seats)	100	118.1	11810
Passengers (Rear Seats)		155.7	
Passenger (Jump Seat) (Optional)		118.1	
Fuel (94 Gallon Maximum) 6 LBS PER GAL.	564	93.6	52790.40
Baggage (Forward)	80	42.0	2100
Baggage (Aft)	100	178.7	17870
Moment due to Retraction of Landing Gear			819
Total Loaded Airplane	3113	86.64	298407.60

Totals must be within approved weight and C.G. limits. It is the responsibility of the airplane owner and the pilot to insure that the airplane is loaded properly. The Basic Empty Weight C.G. is noted on the Weight and Balance Data Form (Figure 6-5). If the airplane has been altered, refer to the Weight and Balance Record for this information.

WEIGHT AND BALANCE LOADING FORM

Figure 6-11

SECTION 6
WEIGHT AND BALANCE

PIPER AIRCRAFT CORPORATION
PA-32R-300, CHEROKEE LANCE

WITH CENTER SEATS & CONSOLE INSTALLED

N4505X SN: 32R-7680022	Weight (Lbs)	Arm Aft Datum (Inches)	Moment (In-Lbs)
Basic Empty Weight	2242.00	80.49	180449.30
Pilot and Front Passenger		85.5	
Passengers (Center Seats)		118.1	
Passengers (Rear Seats)		155.7	
Passenger (Jump Seat) (Optional)		118.1	
Fuel (94 Gallon Maximum) 6 Lbs PER GAL.		93.6	
Baggage (Forward)		42.0	
Baggage (Aft)		178.7	
Moment due to Retraction of Landing Gear			819
Total Loaded Airplane			

Totals must be within approved weight and C.G. limits. It is the responsibility of the airplane owner and the pilot to insure that the airplane is loaded properly. The Basic Empty Weight C.G. is noted on the Weight and Balance Data Form (Figure 6-5). If the airplane has been altered, refer to the Weight and Balance Record for this information.

WEIGHT AND BALANCE LOADING FORM

Figure 6-11

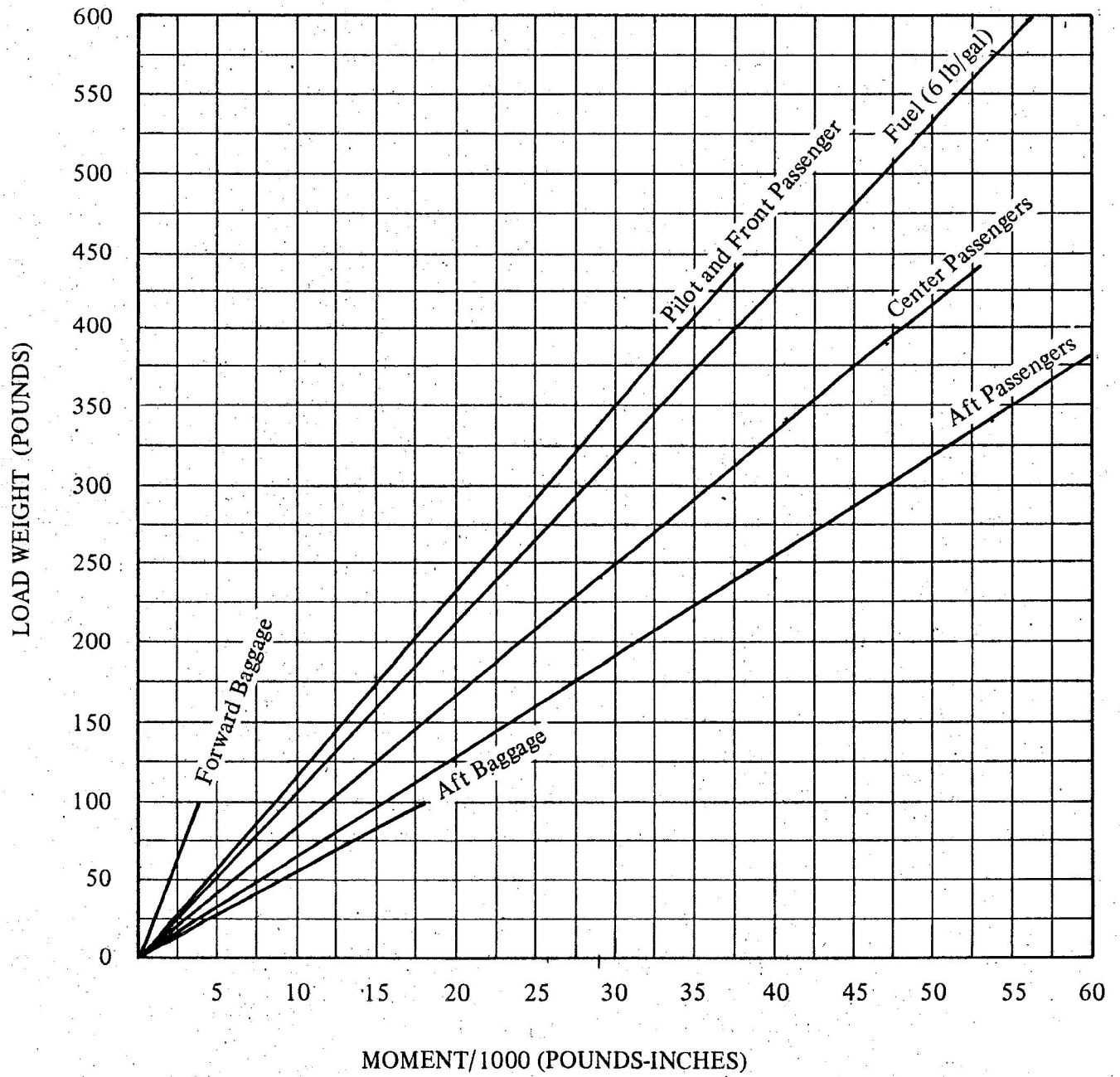

LOADING GRAPH

Figure 6-13

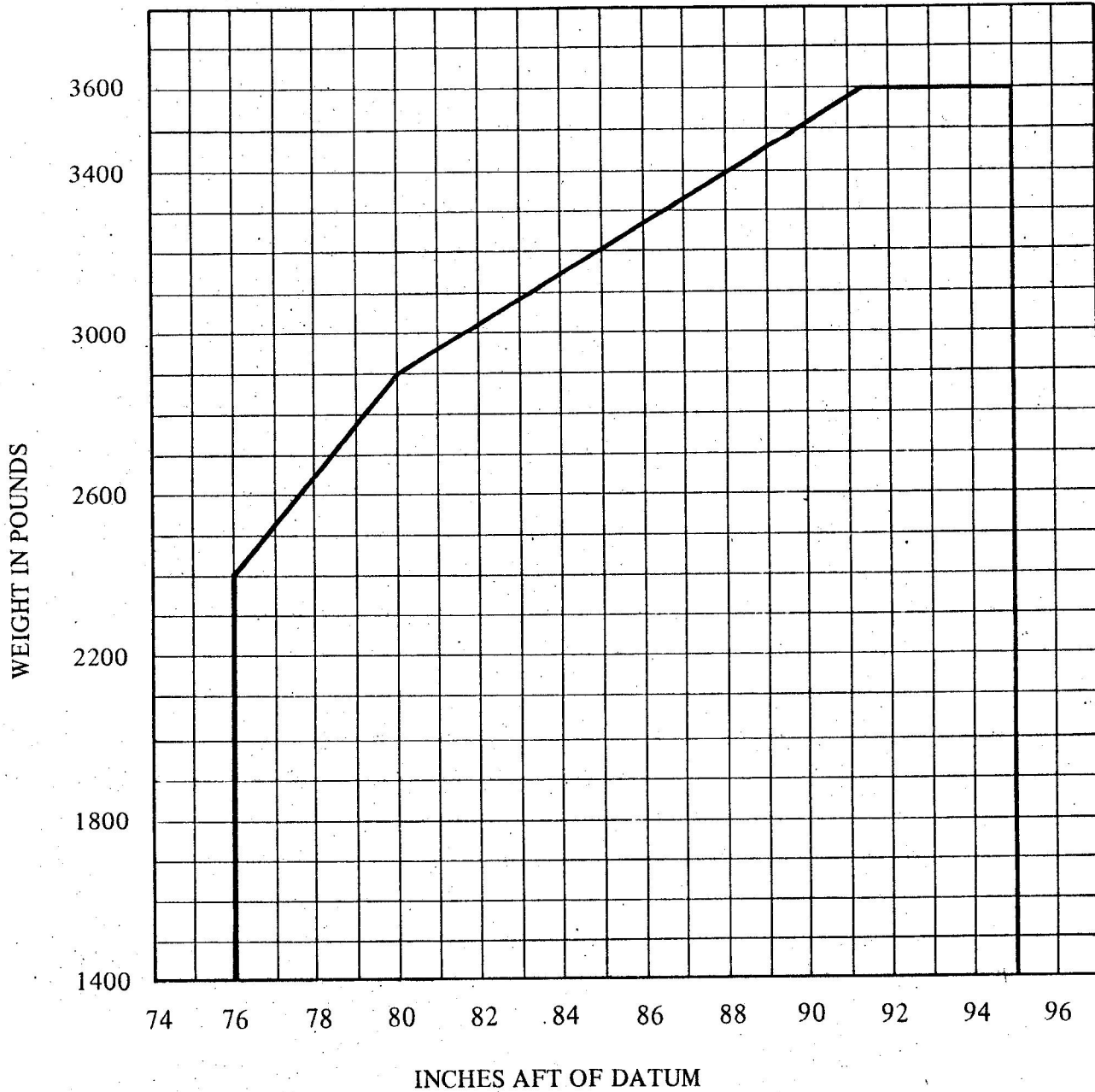

Moment due to retracting landing gear = +819 in. lbs.

C. G. RANGE AND WEIGHT

Figure 6-15

ISSUED: AUGUST 1, 1975

THIS PAGE INTENTIONALLY LEFT BLANK

THIS PAGE INTENTIONALLY LEFT BLANK

6.9 EQUIPMENT LIST

The following is a list of equipment which may be installed in the PA-32R-300. It consists of those items used for defining the configuration of an airplane when the basic empty weight is established at the time of delivery. Only those standard items which are alternate standard items and those required to be listed by the certificating authority (FAA) are presented. Items marked with an "X" are those items which were installed on the airplane described below as delivered by the manufacturer.

PIPER AIRCRAFT CORPORATION

PA-32R-300 CHEROKEE LANCE

SERIAL NO. 32R-7680022 REGISTRATION NO. N4505X DATE: 10/14/75

(a) Propeller and Propeller Accessories

Item No.	Item	Mark if Instl.	Weight (Pounds)	Arm (In.) Aft Datum	Moment (Lb-In.)
1	Propeller, Hartzell HC-C2YK-1/8475D-4 Cert. Basis - TC P920				
3	Propeller Governor Piper Dwg. 66634-8 Cert. Basis - TC P920				

THIS PAGE INTENTIONALLY LEFT BLANK

(b) Engine and Engine Accessories

Item No.	Item	Mark if Instl.	Weight (Pounds)	Arm (In.) Aft Datum	Moment (Lb-In.)
5	Lycoming Model IO-540-K1A5D (Serial Nos. 7680001 through 7680140) Cert. Basis - TC 1E4				
6	Lycoming Model IO-540-K1G5D (Serial Nos. 7680141 and up) Cert. Basis - TC 1E4				
7	Air Filter - Fram Model *CA-161 PL Cert. Basis - TC 1E4				

THIS PAGE INTENTIONALLY LEFT BLANK

(c) Landing Gear and Brakes

Item No.	Item	Mark if Instl.	Weight Pounds)	Arm (In.) Aft Datum	Moment (Lb-In.)
11	Two Main Wheel Assemblies				
	a. Cleveland Aircraft Products				
	Wheel Assy. No. 40-90				
	Brake Assy. No. 30-65				
	Cert. Basis - TSO C26a				
	b. 6.00-6 Type III 8 Ply				
	Rating Tires with Regular Tubes				
	Cert. Basis - TSO C26b				
13	Nose Wheel Assembly				
	a. Cleveland Aircraft Products				
	Wheel Assy. No. 40-77				
	Cert. Basis - TSO C26a				
	b. 5.00-5 Type III 6 Ply				
	Rating Tire with Regular Tube				
	Cert. Basis - TSO C26b				

THIS PAGE INTENTIONALLY LEFT BLANK

(d) Electrical Equipment

Item No.	Item	Mark if Instl.	Weight (Pounds)	Arm (In.) Aft Datum	Moment (Lb.-In.)
----------	------	----------------	-----------------	---------------------	------------------

THIS PAGE INTENTIONALLY LEFT BLANK

(e) Instruments

Item No.	Item	Mark if Instl.	Weight (Pounds)	Arm (In.) Aft Datum	Moment (Lb-In.)
21	Altimeter, Piper PS50008-2, -3, -4 or -5 Cert. Basis - TSO C10b				
23	Airspeed Indicator Piper PS50049-22 Cert. Basis - TSO C2b				
25	Manifold Pressure and Fuel Flow Indicator Piper PS50031-7 Cert. Basis - TSO C45, C47				

THIS PAGE INTENTIONALLY LEFT BLANK

(f) Miscellaneous

Item No.	Item	Mark if Instl.	Weight (Pounds)	Arm (In.) Aft Datum	Moment (Lb-In.)
33	Front Seat Belts (2) Piper PS50039-4-2A Cert. Basis - TSO C22f				
35	Center Seat Belts (2) Piper PS50039-4-3A Cert. Basis - TSO C22f				
37	Aft Seat Belts (2) Piper PS50039-4-4A Cert. Basis - TSO C22f				

THIS PAGE INTENTIONALLY LEFT BLANK

(g) Engine and Engine Accessories
(Optional Equipment)

Item No.	Item	Mark if Instl.	Weight (Pounds)	Arm (In.) Aft Datum	Moment (Lb-In.)
49	Vacuum Filter, Piper Dwg. 66673 Cert. Basis - TC A3SO	<u> X </u>	.3	57.0	17
51	Vacuum Pump, Airborne Mfg. Co., Model 211cc and Drive, Piper Dwg. 79399-0 Cert. Basis - TC A3SO	<u> X </u>	3.4	25.9	88
53	Low Vacuum Annunciator Light, Cert. Basis - TC A3SO	<u> X </u>	Negligible		
55	Vacuum Regulator, Airborne Mfg. Co., #2H3-19 Cert. Basis - TC A3SO	<u> X </u>	.5	57.0	28

THIS PAGE INTENTIONALLY LEFT BLANK

(h) Propeller and Propeller Accessories
(Optional Equipment)

Item No.	Item	Mark if Instl.	Weight (Pounds)	Arm (In.) Aft Datum	Moment (Lb-In.)
-------------	------	-------------------	--------------------	------------------------	--------------------

THIS PAGE INTENTIONALLY LEFT BLANK

(i) Landing Gear and Brakes
(Optional Equipment)

Item No.	Item	Mark if Instl.	Weight (Pounds)	Arm (In.) Aft Datum	Moment (Lb-In.)
	Heavy Duty Group No. 1				
65	a. Cleveland Aircraft Products 40-120 Wheel Assy. (2) 30-83 Brake Assy. (2) Cert. Basis - TSO C26a				
	Goodrich 6.00 x 6 Ribbed Type III 8 Ply Rating Tire with Tube (2) Cert. Basis - TSO C62	_____	*2.9	109.8	318
67	b. Goodrich 5.00 x 5 Ribbed Type III 6 Ply Rating Tire with Tube Cert. Basis - TSO C62	_____	(Same as standard equipment)		

*Weight and moment difference between standard and optional equipment.

THIS PAGE INTENTIONALLY LEFT BLANK

(j) Electrical Equipment (Optional Equipment)

Item No.	Item	Mark if Instl.	Weight (Pounds)	Arm (In.) Aft Datum	Moment (Lb-In.)
79	Landing Light, G. E. Model 4509 Cert. Basis - TC A3SO	_____	.5	-2.6	-1
81	Auxiliary Power Receptacle, Piper Dwg. 68815 Cert. Basis - TC A3SO	_____	2.6	48.4	126
83	External Power Cable, Piper Dwg. 62355-2 Cert. Basis - TC A3SO	_____	4.6	42.0	193
85	Cabin Speaker, Piper Dwg. 63239-2 Cert. Basis - TC A3SO	_____	.8	97.5	78
87	Instrument Light (2), Grimes 15-0083-7 Cert. Basis - TC A3SO	_____	.2	99.0	20
89	Forward Baggage Light, Piper Dwg. 68697 Cert. Basis - TC A3SO	_____	.2	43.5	9
91	a. Reading Light (2), Grimes *10-0154-1 Cert. Basis - TC A3SO	_____	0.5	149.3	75
	b. Reading Light (2), Grimes *10-0154-1 Cert. Basis - TC A3SO	_____	0.5	115.0	58
93	Heated Pitot Head, Piper Dwg. 65797-5 Cert. Basis - TC A3SO	_____	.4	100.0	40
95	Battery 12V 35 A.H. Rebat R35 (Wt. 27.2 lbs.) Cert. Basis - TC A3SO	_____	*5.3	41.4	219

*Weight and moment difference between standard and optional equipment.

SECTION 6
WEIGHT AND BALANCE

PIPER AIRCRAFT CORPORATION
PA-32R-300, CHEROKEE LANCE

(j) Electrical Equipment (Optional
Equipment) (cont)

Item No.	Item	Mark if Instl.	Weight (Pounds)	Arm (In.) Aft Datum	Moment (Lb-In.)
97	Instrument Panel Lights Cert. Basis - TC A3SO	_____	0.3	67.8	20
99	Anti-Collision Lights (Wing Tip) (Whelen) Piper Dwg. 38221 Cert. Basis - STC SA 615 EA	_____	5.5	186.5	1026
100	Navigation Lights (Wing) (2) Grimes A1285 (Red and Green) Cert. Basis - TC A3SO	_____	0.4	106.6	43
101	Navigation Light (Rear) (1), Grimes Model A2064 (White) Cert. Basis - TC A3SO	_____	.2	311.7	62
103	Piper Pitch Trim Piper Dwg. 69378-2 Cert. Basis - TC A3SO	_____	4.7	183.2	861
105	Rotating Beacon Cert. Basis - TC A3SO	_____	1.5	290.3	435

(k) Instruments (Optional Equipment)

Item No.	Item	Mark if Instl.	Weight (Pounds)	Arm (In.) Aft Datum	Moment (Lb-In.)
113	Suction Gauge, Piper Dwg. 99480-0 or -2 Cert. Basis - TC A3SO	<u>X</u>	.5	67.2	34
115	a. Vertical Speed, Piper Dwg. 99010-2, -4 or -5 Cert. Basis - TSO C8b	<u>X</u>	1.0	65.9	66
	b. Vertical Speed, Piper Dwg. 99010-3 Cert. Basis - TSO C8b	<u> </u>	.5	67.2	34
117	Attitude Gyro, Piper Dwg. 99002-2, -3, -4 or -5 Cert. Basis - TSO C4c	<u> </u>	2.2	64.4	142
119	Directional Gyro, Piper Dwg. 99003-2, -3, -4 or -5 Cert. Basis - TSO C5c	<u> </u>	2.6	64.7	168
121	Air Temperature Gauge, Piper Dwg. 99479-0 or -2 Cert. Basis - TC A3SO	<u>X</u>	.2	77.6	16
123	Clock Cert. Basis - TC A3SO	<u>X</u>	.4	67.4	27
125	Tru-Speed Indicator, Piper Dwg. 62143-9 and -23 Cert. Basis - TSO C2b	<u>X</u>	(same as standard equipment)		
127	Turn and Slip Indicator, Piper PS50030-2 or -3 Cert. Basis - TSO C3b	<u>X</u>	2.6	64.7	168
129	Exhaust Gas Temperature, Piper Dwg. 99026 Cert. Basis - TC A3SO	<u>X</u>	.7	60.4	42
131	Encoding Altimeter, Piper PS50008-6 or -7 Cert. Basis - TSO C10b C88	<u>X</u>	* .9	65.3	59

*Weight and moment difference between standard and optional equipment.

**SECTION 6
WEIGHT AND BALANCE**

**PIPER AIRCRAFT CORPORATION
PA-32R-300, CHEROKEE LANCE**

(k) Instruments (Optional
Equipment) (cont)

Item No.	Item	Mark if Instl.	Weight (Pounds)	Arm (In.) Aft Datum	Moment (Lb-In.)
133	Engine Hour Meter Piper Dwg. 69889-0 Cert. Basis - TC A3SO	_____	0.3	66.2	20
135	MK10 Radar Altimeter Piper Dwg. 37693-2 Cert. Basis - TC A3SO	_____	5.4	181.3	979
137	NSD-360 Gyro Cert. Basis - STC C6c, C9c, C52c	_____	4.1	64.9	266
a.	Narco OC-110 Converter and Mount Cert. Basis - TSO C36c C40a	_____	2.1	217.6	457

(I) Autopilots (Optional Equipment)

Item No.	Item	Mark if Instl.	Weight (Pounds)	Arm (In.) Aft Datum	Moment (Lb-In.)
147	AutoFlite II Cert. Basis - STC SA3054SW-D	_____	5.2	92.8	483
149	AutoControl IIIB Cert. Basis - STC SA3053SW-D	_____	6.7	88.5	593
	a. Directional Gyro *52D54	_____	2.9	64.0	186
	b. Omni Coupler 1C-388	_____	1.0	64.3	64
151	AltiMatic IIIC Cert. Basis - STC SA3052SW-D	_____ X	21.3	126.6	2697
	a. Directional Gyro *52D54	_____ X	2.9	64.9	188
	b. Omni Coupler 1C-388	_____ X	1.0	64.3	64
	c. G/S Coupler 1C-493	_____ X	1.5	56.7	85

THIS PAGE INTENTIONALLY LEFT BLANK

(m) Radio Equipment
(Optional Equipment)

Item No.	Item	Mark if Instl.	Weight (Pounds)	Arm (In.) Aft Datum	Moment (Lb-In.)
161	King KX 170 () (VHF Comm/Nav)	_____	7.5	61.6	462
	Transceiver, Single	<u> X </u>	15.0	61.6	924
	Transceiver, Dual	_____			
	Cert. Basis - TC A3SO				
163	King KX 175 () VHF Transceiver,	_____	8.1	61.6	499
	King KN 73 Glide Slope Receiver,	_____	2.8	214.8	601
	King KN 77 VOR/LOC Converter,	_____	3.1	214.8	666
	King KNI 520 VOR/ILS Indicator	_____	1.7	65.5	111
	Cert. Basis - TSO C3bc, C37b, C38b, C40a				
165	King KX 175 () VHF Transceiver (2nd),	_____	7.8	61.6	480
	King KN 77 VOR/LOC Converter,	_____	3.5	214.8	752
	King KNI 520 VOR/ILS Indicator	_____	1.7	65.5	111
	Cert. Basis - TSO C36c, C37b, C38b, C40a				
167	King KI 201 () VOR/LOC Ind.	_____			
	Cert. Basis - TC A3SO	<u> X </u>			
	a. Single	_____	2.5	64.9	162
	b. Dual	_____	5.0	64.9	325
169	King KI 213 VOR/LOC/GS Indicator	_____			
	Cert. Basis - TC A3SO		2.5	64.9	162
171	King KI 214 () VOR/LOC/GS Ind.	<u> X </u>			
	Cert. Basis - TC A3SO	_____	3.3	64.9	214
173	Narco Comm 10A VHF Transceiver	_____			
	Cert. Basis - TC A3SO		3.9	62.4	243

SECTION 6
WEIGHT AND BALANCE

PIPER AIRCRAFT CORPORATION
PA-32R-300, CHEROKEE LANCE

(m) Radio Equipment
(Optional Equipment) (cont)

Item No.	Item	Mark if Instl.	Weight (Pounds)	Arm (In.) Aft Datum	Moment (Lb-In.)
175	Narco Nav 10 VHF Receiver Cert. Basis - TC A3SO	_____	1.9	63.6	121
177	Narco Nav 11 VHF Receiver Cert. Basis - TC A3SO				
	a. Single	_____	2.8	63.6	178
	b. Dual	_____	5.6	63.6	356
179	Narco Comm 11A VHF Transceiver Cert. Basis - TC A3SO				
	a. Single	_____	3.6	62.4	225
	b. Dual	_____	7.1	62.4	443
181	Narco Comm 11B VHF Transceiver Cert. Basis - TC A3SO				
	a. Single	_____	3.9	62.4	243
	b. Dual	_____	7.8	62.4	487
183	Narco Nav 12 VHF Receiver Cert. Basis - TC A3SO	_____	3.4	63.6	216
185	Narco Nav 14 VHF Receiver Cert. Basis - TC A3SO	_____	2.5	62.4	156
187	Narco Comm 111 VHF Transceiver Cert. Basis - TSO C37b, C38b				
	a. Single	_____	3.0	62.4	187
	b. Dual	_____	6.0	62.4	374
189	Narco Nav 111 Cert. Basis - TSO C36c, C40a, C66a	_____	2.5	63.6	159

(m) Radio Equipment
(Optional Equipment) (cont)

Item No.	Item	Mark if Instl.	Weight (Pounds)	Arm (In.) Aft Datum	Moment (Lb-In.)
191	Narco Comm 111B VHF Transceiver				
	Cert. Basis - TSO C37b, C38b				
	a. Single	_____	3.9	62.4	243
	b. Dual	_____	7.8	62.4	487
193	Narco Nav 112 Receiver				
	Cert. Basis - TSO C36c, C40a, C66c, C34c	_____	3.3	63.6	210
195	Narco Nav 114 VHF Receiver				
	Cert. Basis - TSO C38b, C40a, C36c, C34c, C66a	_____	2.5	62.4	156
197	Narco UGR-3 Glide Slope Receiver	_____	2.3	215.6	496
	Cable	_____	1.5	139.3	209
	Antenna	_____	0.4	92.4	37
	Cable, Antenna	_____	0.5	150.0	75
	Cert. Basis - TC A3SO				
198	Narco UGR-2A Glide Slope Receiver	_____	2.3	215.6	496
	Cable	_____	1.5	139.3	209
	Antenna	_____ <i>✓</i>	0.4	92.4	37
	Cable, Antenna	_____ <i>✓</i>	0.5	150.0	75
	Cert. Basis - TSO C34b				
199	Narco MBT-12-R, Marker Beacon				
	Cert. Basis - TC A3SO	_____	3.0	113.2	340
201	King KN 74 R-Nav				
	Cert. Basis - TC A3SO	_____	4.7	61.3	288
202	Narco CLC-60A R-Nav				
	Cert. Basis - TC A3SO	_____	11.5	133.9	1540
203	King KN 60C DME				
	Cert. Basis - TC A3SO	_____	7.3	64.1	468

SECTION 6
WEIGHT AND BALANCE

PIPER AIRCRAFT CORPORATION
PA-32R-300, CHEROKEE LANCE

(m) Radio Equipment
(Optional Equipment) (cont)

Item No.	Item	Mark if Instl.	Weight (Pounds)	Arm (In.) Aft Datum	Moment (Lb-In.)
204	King KN 61 DME Cert. Basis - TC A3SO	_____	13.3	189.5	2520
205	King KN 65 DME Cert. Basis - TSO C66a	_____X	9.1	205.1	1866
206	King KN 65A DME Cert. Basis - TSO C66a	_____	13.8	185.4	2559
207	Narco DME-190 Cert. Basis - TC A3SO	_____	5.9	65.9	389
209	King KR 85 Digital ADF Cert. Basis - TSO C41b	_____	8.6	96.6	831
	a. Audio Amplifier	_____	0.8	54.1	43
211	King KR 86 ADF Cert. Basis - TC A3SO	_____			
	a. First	_____X	6.7	104.8	702
	b. Second	_____	9.7	108.9	1057
	c. Audio Amplifier	_____	0.8	54.1	43
213	Narco ADF-140 Cert. Basis - TSO C41c	_____			
	a. Single	_____	6.0	94.3	566
	b. Dual	_____	18.3	110.7	2026
215	King KMA 20 () Audio Panel	_____X	2.8	65.2	183
	Antenna	_____X	.5	116.3	58
	Cable	_____X	.4	90.0	36
	Cert. Basis - TSO C35c, C50b				
217	Narco CP-125 Audio Selector Panel	_____			
	Cert. Basis - TC A3SO	_____	2.2	76.2	168

(m) Radio Equipment
(Optional Equipment) (cont)

Item No.	Item	Mark if Instl.	Weight (Pounds)	Arm (In.) Aft Datum	Moment (Lb-In.)
219	King KT 76/78 Transponder Panel Unit	<u>✓</u>	3.1	63.1	196
	Antenna and Cable Cert. Basis - TSO C74b	<u>✓</u>	—	—	—
221	Narco AT50A Transponder Panel Unit Cert. Basis - TSO C74b	_____	*3.0	62.3	187
223	Nav Receiving Antenna Cert. Basis - TC A3SO				
	a. Antenna	<u>✓</u>	.5	291.0	146
	b. Cable	<u>✓</u>	1.1	172.0	189
225	VHF Comm Antennas Cert. Basis - TC A3SO				
	a. *1 Antenna	_____	.3	186.8	56
	b. *1 Cable	_____	.5	122.0	61
	c. *2 Antenna	_____	.3	222.0	67
	d. *2 Cable	_____	.6	160.0	96
226	Single ADF Sense Antenna and Cable Cert. Basis - TC A3SO	_____	0.4	160.0	64
227	Anti Static Kit Cert. Basis - TC A3SO				
	a. *1 VHF Comm Antenna and Cable	<u>✓</u>	1.5	162.7	252
	b. *2 VHF Comm Antenna and Cable	<u>✓</u>	1.6	192.5	308
	c. Low Frequency Antenna	<u>✓</u>	0.6	160.0	96
	d. Static Wicks	<u>✓</u>	—	—	—

*Weight includes antenna and cable.

**SECTION 6
WEIGHT AND BALANCE**

**PIPER AIRCRAFT CORPORATION
PA-32R-300, CHEROKEE LANCE**

(m) Radio Equipment
(Optional Equipment) (cont)

Item No.	Item	Mark if Instl.	Weight (Pounds)	Arm (In.) Aft Datum	Moment (Lb-In.)
229	Emergency Locator Transmitter Cert. Basis - TC A3SO				
	a. Transmitter, Piper Dwg. 79265-0	<u>✓</u>	1.7	267.2	454
	b. Transmitter, Piper Dwg. 79265-6	<u>✓</u>	1.3	267.2	347
	c. Antenna and Coax	<u>✓</u>	0.2	255.4	51
231	Microphone Cert. Basis - TC A3SO				
	a. Piper Dwg. 68856-10	<u>✓</u>	0.3	69.9	21
	b. (Dynamic) Piper Dwg. 68856-11	<u>✓</u>	0.6	74.9	45
	c. (Dynamic) Piper Dwg. 68856-12	<u>✓</u>	0.3	69.9	21
233	Headset, Piper Dwg. 68856-10 Cert. Basis - TC A3SO	<u>✓</u>	.5	65.0	33
235	Radio Shelf, Piper Dwg. 67367-0 Cert. Basis - TC A3SO	<u>✓</u>	2.3	201.8	464

THIS PAGE INTENTIONALLY LEFT BLANK

THIS PAGE INTENTIONALLY LEFT BLANK

(n) Miscellaneous (Optional Equipment)

Item No.	Item	Mark if Instl.	Weight (Pounds)	Arm (In.) Aft Datum	Moment (Lb-In.)
263	Assist Step, Piper Dwg. 65384 Cert. Basis - TC A3SO	<u> X </u>	1.5	147.5	221
265	Jump Seat (with seat belts), Piper Dwg. 69595-4 Cert. Basis - TC A3SO	<u> </u>	9.2	122.3	1125
267	Alternate Static Source Cert. Basis - TC A3SO	<u> X </u>	.4	66.0	26
	Calibrated Alternate Static Source	<u> X </u>			
	Placard Required: Yes _____ No _____				
269	Ground Ventilating Blower, Piper Dwg. 79273-5 Cert. Basis - TC A3SO	<u> X </u>	7.7	201.4	1551
271	Super Cabin Sound Proofing, Piper Dwg. 78480 Cert. Basis - TC A3SO	<u> X </u>	24.4	107.2	2616
273	Assist Straps, Piper Dwg. 79455 Cert. Basis - TC A3SO	<u> X </u>	.3	120.0	36
275	Inertia Safety Belts (Center) (2) .75 lbs. each, Piper PS50039-4-15 Cert. Basis - TC A3SO	<u> </u>	1.5	133.9	201
277	Inertia Safety Belts (Rear) (2) 0.8 lbs. each, Piper PS50039-4-14 Cert. Basis - TC A3SO	<u> </u>	1.6	181.5	290
279	Lighter, * 200462, 12 Volt Universal Cert. Basis - TC A3SO	<u> X </u>	.2	67.9	14

REPORT: VB-750

ISSUED: AUGUST 1, 1975

**SECTION 6
WEIGHT AND BALANCE**

**PIPER AIRCRAFT CORPORATION
PA-32R-300, CHEROKEE LANCE**

(n) Miscellaneous (Optional Equipment) (cont)

Item No.	Item	Mark if Instl.	Weight (Pounds)	Arm (In.) Aft Datum	Moment (Lb-In.)
281	Fire Extinguisher, Piper Dwg. 76167-2 Cert. Basis - TC A3SO	_____	4.6	71.0	327
283	Adjustable Front Seat (Left), Piper Dwg. 79592-0 Cert. Basis - TC A3SO	<u> x </u>	*4.6	84.7	390
285	Adjustable Front Seat (Right), Piper Dwg. 79592-1 Cert. Basis - TC A3SO	<u> x </u>	*4.6	84.1	387
287	Headrests (2) Front, Piper Dwg. 79337-18 Cert. Basis - TC A3SO	_____	2.0	99.5	199
289	Headrests (2) Center, Piper Dwg. 79337-18 Cert. Basis - TC A3SO	_____	2.0	132.1	264
291	Headrests (2) Rear, Piper Dwg. 79337-18 Cert. Basis - TC A3SO	_____	2.0	169.7	339
293	Air Conditioner, Piper Dwg. 99750-3 Cert. Basis - TC A3SO	_____	69.5	113.5	7888

*Weight and moment difference between standard and optional equipment.

(n) Miscellaneous (Optional Equipment) (cont)

Item No.	Item	Mark if Instl.	Weight (Pounds)	Arm (In.) Aft Datum	Moment (Lb-In.)
295	Zinc Chromate Finish Cert. Basis - TC A3SO	_____	7.5	113.2	849
297	Stainless Steel Control Cables Cert. Basis - TC A3SO	_____	—	—	—
TOTAL OPTIONAL EQUIPMENT			<u>141.1</u>	<u>104.1</u>	14690 -1 <u>14689</u>

EXTERIOR FINISH

Base Color Juneau White
Trim Color Madrid Red
Accent Color Bahama Blue

Registration No. Color Blue
Type Finish Lacquer

ISSUED: AUGUST 1, 1975

REPORT: VB-750

THIS PAGE INTENTIONALLY LEFT BLANK

TABLE OF CONTENTS

SECTION 7

DESCRIPTION AND OPERATION OF THE AIRPLANE AND ITS SYSTEMS

Paragraph No.		Page No.
7.1	The Airplane	7-1
7.3	Airframe	7-1
7.5	Engine and Propeller	7-3
7.7	Induction System	7-3
7.9	Engine Controls	7-4
7.11	Landing Gear	7-6
7.13	Flight Controls	7-10
7.15	Fuel System	7-13
7.17	Electrical System	7-15
7.19	Vacuum System	7-19
7.21	Instrument Panel	7-21
7.23	Pitot-Static System	7-23
7.25	Cabin Features	7-23
7.27	Baggage Area	7-23
7.29	Heating and Ventilating System	7-25
7.31	Stall Warning	7-25
7.33	Finish	7-25
7.35	Air Conditioning	7-25
7.37	Piper External Power	7-26
7.39	Emergency Locator Transmitter	7-27

SECTION 7
DESCRIPTION AND OPERATION
OF THE AIRPLANE AND ITS SYSTEMS

7.1 THE AIRPLANE

The Lance is a single engine, retractable landing gear, all metal airplane which features a spacious and comfortable cabin and Piper's traditional smooth, easy handling characteristics.

Seating for up to seven occupants, two separate one hundred pound luggage compartments, and a fuel capacity of 98 gallons give the Lance a high degree of flexibility. As with any aircraft, the Lance requires proper loading; however a simple-to-use weight and balance calculator provided with each airplane makes the determination of acceptable fuel and payload combinations easy and uncomplicated. Large floor space, easily removable seats, broad, well-placed cabin doors and a nose baggage compartment make the Lance a versatile aircraft for transporting passengers or cargo or a combination of both.

7.3 AIRFRAME

With the exception of the steel engine mount, the landing gear, miscellaneous steel parts, the cowling, and the lightweight plastic extremities (tips of wings, tail fin, rudder and stabilator), the basic airframe is of aluminum alloy. Aerobatics are prohibited in this airplane since the structure is not designed for aerobatic loads.

The fuselage is a semi-monocoque structure. There is a front door on the right side and a rear door on the left. A cargo door is installed aft of the rear passenger door. When both rear doors are open, large pieces of cargo can be loaded through the extra-wide opening. A door on the right side of the nose section gives access to the nose baggage compartment.

The wing is of a conventional design and employs a laminar flow NACA 65₂-415 airfoil section. The main spar is located at approximately 40% of the chord aft of the leading edge. The wings are attached to the fuselage by the insertion of the butt ends of the spar into a spar box carry-through, which is an integral part of the fuselage structure. The bolting of the spar ends into the spar box carry-through structure, which is located under the center seats, provides in effect a continuous main spar. The wings are also attached fore and aft of the main spar by an auxiliary front spar and a rear spar. The rear spar, in addition to taking torque and drag loads, provides a mount for flaps and ailerons. The four-position wing flaps are mechanically controlled by a handle located between the front seats. When fully retracted, the right flap locks into place to provide a step for cabin entry. Each wing contains two interconnected fuel tanks. Both tanks on one side are filled through a single filler neck located in the outboard tank.

A vertical stabilizer, an all-movable horizontal stabilator, and a rudder make up the empennage. The stabilator incorporates an anti-servo tab which improves longitudinal stability and provides longitudinal trim. This tab moves in the same direction as the stabilator, but with increased travel.

THIS PAGE INTENTIONALLY LEFT BLANK

7.5 ENGINE AND PROPELLER

The Lycoming IO-540-K1A5D (Serial Nos. 32R-7680001 through 32R-7680140) or IO-540-K1G5D (Serial Nos. 32R-7680141 through 32R-7680525) engine installed in the PA-32R-300 is rated at 300 horsepower at 2700 rpm. This engine has a compression ratio of 8.7 to 1 and requires 100/130 minimum octane fuel. The engine is equipped with a geared starter, a 60 ampere alternator, dual magnetos, vacuum pump drive, fuel pump, and fuel injection.

The exhaust system consists of individual exhaust pipes routed in pairs to three heavy gauge stainless steel mufflers. Exhaust gases are directed overboard at the underside of the engine cowling. The mufflers are surrounded by a shroud which provides heat for the cabin and for windshield defrosting.

Cowling on the Cherokee Lance is designed to cool the engine in all normal flight conditions, including protracted climb, without the use of cowl flaps or cooling flanges.

The constant speed propeller is a Hartzell HC-C2YK-1()F/F8475D-4 with a diameter of 80 inches. The propeller is controlled by a governor mounted at the left forward side of the crankcase. The governor is operated by a cable from the power control quadrant.

7.7 INDUCTION SYSTEM

An induction scoop is located on the left side of the lower cowl. An intake air box is attached to the inside of the cowl adjacent to the air filter box. The air filter box is located at the aft end of the induction scoop. Access to the filter is gained through a detachable plate located on the outside of the lower cowl.

The intake air box incorporates a manually operated two-way valve designed to allow induction air either to pass through the filter or to bypass the filter and supply heated air directly to the engine. Alternate air selection insures induction air flow should the filter become blocked. Since the air is heated, the alternate air system offers protection against induction system blockage caused by snow or freezing rain, or by the freezing of moisture accumulated in the induction air filter. Alternate air is unfiltered; therefore, it should not be used during ground operation when dust or other contaminants might enter the system. The primary (through the filter) induction source should always be used for takeoffs.

The Bendix RSA-10ED1 type fuel injection system consists of a servo regulator which meters fuel flow in proportion to airflow to the engine, giving the proper fuel-air mixture at all engine speeds, and a fuel flow divider which receives the metered fuel and accurately divides the fuel flow among the individual cylinder fuel nozzles.

A combination fuel flow indicator and manifold pressure gauge is installed in the left side of the instrument panel. The fuel flow indicator is connected to the fuel flow divider and monitors fuel pressure. The instrument converts fuel pressure to an accurate indication of fuel flow in gallons per hour and percentage of cruise power.

7.9 ENGINE CONTROLS

Engine controls consist of a throttle control, a propeller control and a mixture control lever. These controls are located on the control quadrant on the lower center of the instrument panel (Figure 7-1) where they are accessible to both the pilot and the copilot. The controls utilize teflon-lined control cables to reduce friction and binding.

The throttle lever is used to adjust the manifold pressure. It incorporates a gear up warning horn switch which is activated during the last portion of travel of the throttle levers to the low power position. If the landing gear is not locked down, the horn will sound until the gear is down and locked or until the power setting is increased. This is a safety feature to prevent an inadvertent gear up landing.

The propeller control lever is used to adjust the propeller speed from high RPM to low RPM.

The mixture control lever is used to adjust the air to fuel ratio. The engine is shut down by the placing of the mixture control lever in the full lean position. In addition, the mixture control has a lock to prevent activation of the mixture control instead of the pitch control. For information on the leaning procedure, see the Avco-Lycoming Operator's Manual.

The friction adjustment lever on the right side of the control quadrant may be adjusted to increase or decrease the friction holding the throttle, propeller, and mixture controls or to lock the controls in a selected position.

The alternate air control is located to the right of the control quadrant. When the alternate air lever is in the up, or closed, position the engine is operating on filtered air; when the lever is in the down, or open, position the engine is operating on unfiltered, heated air. The control is operated by pressing the knob to the left to clear the retaining gate and then moved in the desired direction (refer to Figure 7-1).

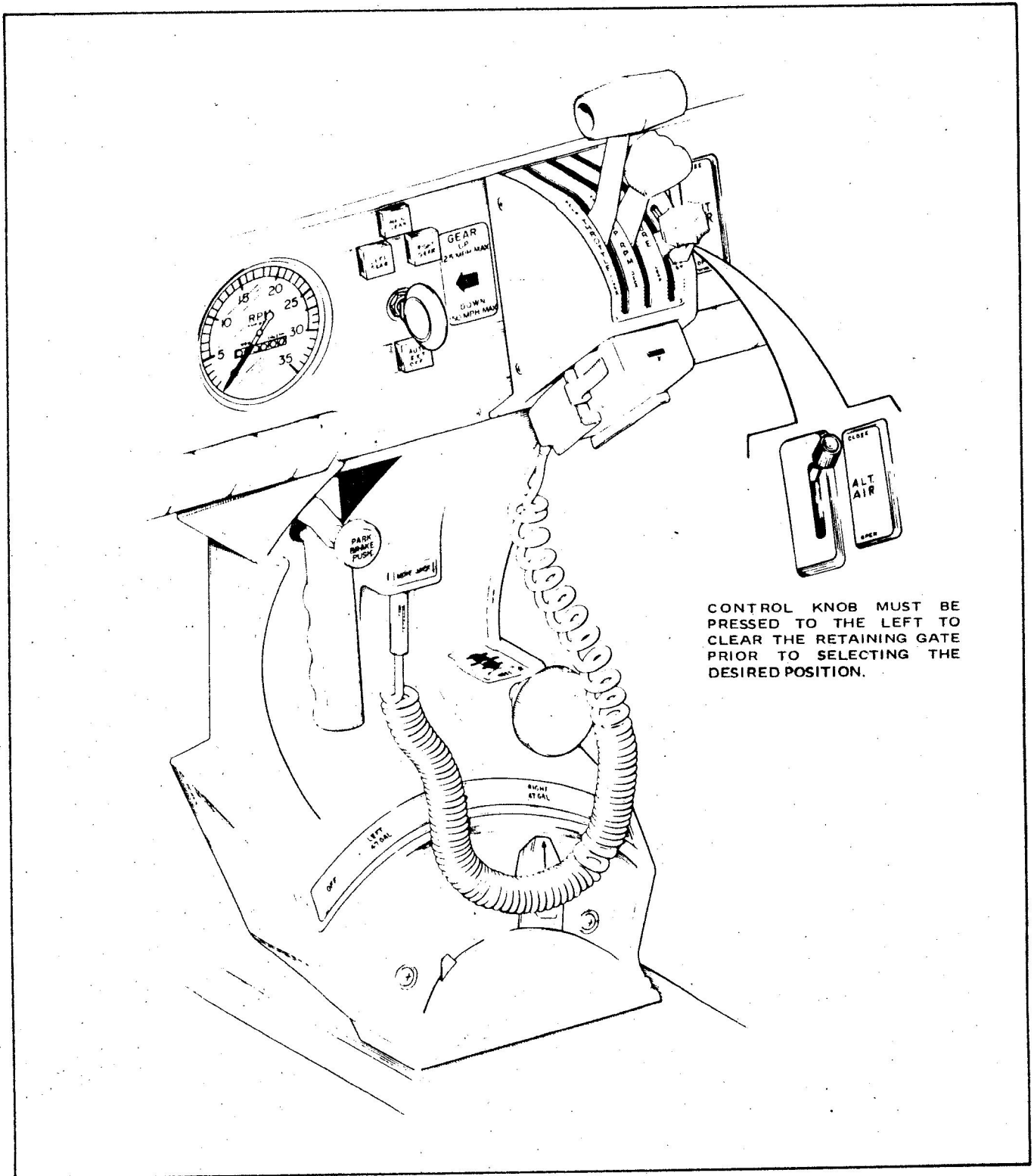

CONTROL QUADRANT AND CONSOLE

Figure 7-1

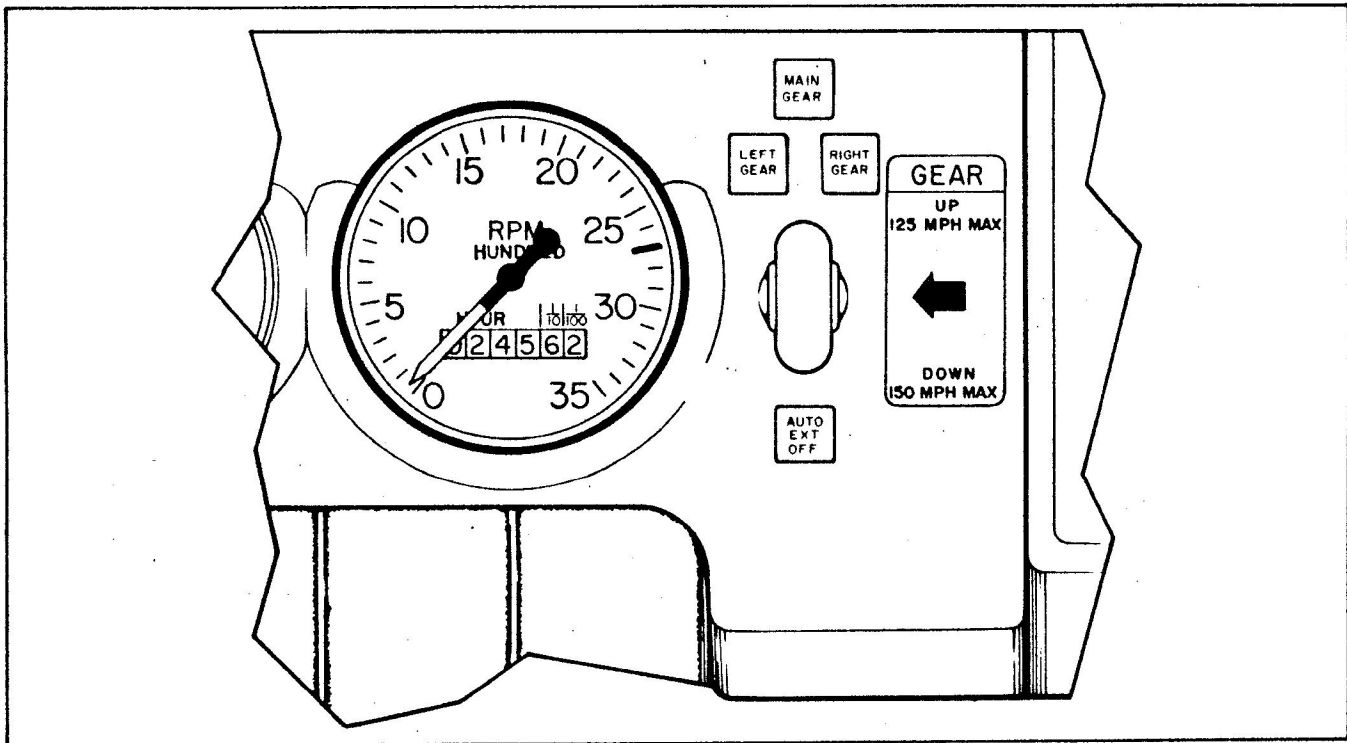

LANDING GEAR SELECTOR

Figure 7-3

7.11 LANDING GEAR

The Cherokee Lance is equipped with a retractable tricycle landing gear, which is hydraulically actuated by an electrically powered reversible pump. The pump is controlled by a selector switch on the instrument panel to the left of the control quadrant (Figure 7-3). The landing gear is retracted or extended in about seven seconds.

Also incorporated in the system is a pressure sensing device which lowers the gear regardless of gear selector position, depending upon airspeed and engine power (propeller slipstream). Gear extension is designed to occur, even if the selector is in the up position, at airspeeds below approximately 118 MPH with power off. The extension speeds will vary from approximately 93 MPH to approximately 118 MPH depending on power settings and altitude. The device also prevents the gear from retracting at airspeeds below approximately 93 MPH with full power, though the selector switch may be in the up position. This speed increases with reduced power and/or increased altitude. Manual override of the device is provided by an emergency gear lever located between the front seats to the right of the flap handle (refer to Figure 7-9). The sensing device operation is controlled by differential air pressure across a flexible diaphragm which is mechanically linked to a hydraulic valve and an electrical switch which actuates the pump motor. A high pressure and static air source for actuating the diaphragm is provided in a mast mounted on the left side of the fuselage above the wing. Any obstruction of the holes in this mast will cause the gear to extend. An optional heated mast is available to alleviate obstruction in icing conditions. The optional heated mast is turned on whenever the "PITOT HEAT" is turned on.

WARNING

Avoid ejecting objects out of the pilot storm window which could possibly enter or obstruct the holes in the mast.

The emergency gear lever, used for emergency extension of the gear, manually releases hydraulic pressure to permit the gear to free-fall with spring assistance on the nose gear. The lever must be held in the downward position for emergency extension. This same lever, when placed in the raised position, can be used to override the system, and gear position is then controlled by the selector switch regardless of airspeed/power combinations. The emergency gear lever is provided with a latching device which may be used to lock the override lever in the up position. The latch is located on the right side panel of the console below the level of the manual override lever. To lock the override lever in the up position, raise the override lever to the full up position and push the latch down. A yellow warning light located below the gear selector switch (Figure 7-3) flashes to warn the pilot that the automatic gear lowering system is disabled. The latch is spring-loaded to the off position to aid disengagement. To disengage the latch raise the override lever and release. The lever will return to its normal position and the yellow flashing light will extinguish. The lever must also be latched in the raised (up) position when gear-up stalls are practiced.

Gear down and locked positions are indicated by three green lights located above the selector, and a red "Warning Gear Unsafe" light is located at the top of the panel. An all lights out condition indicates the gear is up. The landing gear should not be retracted above a speed of 125 MPH and should not be extended above a speed of 150 MPH.

The main landing gear uses Cleveland 6.00 x 6 wheels. The main gear incorporate brake drums and Cleveland double disc hydraulic brake assemblies. The nose wheel carries a 5.00 x 5 six ply tire and the main gear use 6.00 x 6 eight ply tires. All three tires are tube type.

Two micro-switches in the throttle quadrant activate a warning horn and red "Warning Gear Unsafe" light under the following conditions:

1. Gear up and power reduced below approximately 14 inches of manifold pressure.
2. Gear extended by back-up gear extender system but gear selector switch "UP," except at full throttle.
3. Gear selector switch "UP" while on the ground.

The gear warning horn emits a 90 cycle per minute beeping sound in contrast to the stall warning horn which emits a continuous sound.

The nose gear is steerable through a 22.5 degree arc each side of center through the use of the rudder pedals. As the nose wheel retracts, the steering linkage disengages to reduce rudder pedal loads in flight. The nose wheel is equipped with a hydraulic shimmy dampener to reduce nose wheel shimmy.

The oleo struts are of the air-oil type, with normal extension being 2.60 inches for the nose gear and 4.0 inches for the main gear under normal static load (empty weight of airplane plus full fuel and oil).

The standard brake system includes toe brakes on the left and right set of rudder pedals and a hand brake located below and near the center of the instrument panel. The toe brakes and the hand brake have individual brake cylinders, but all cylinders use a common reservoir. The parking brake is incorporated in the lever brake and is operated by pulling back on the lever and depressing the knob attached to the top of the handle. To release the parking brake, pull back on the brake lever; then allow the handle to swing forward.

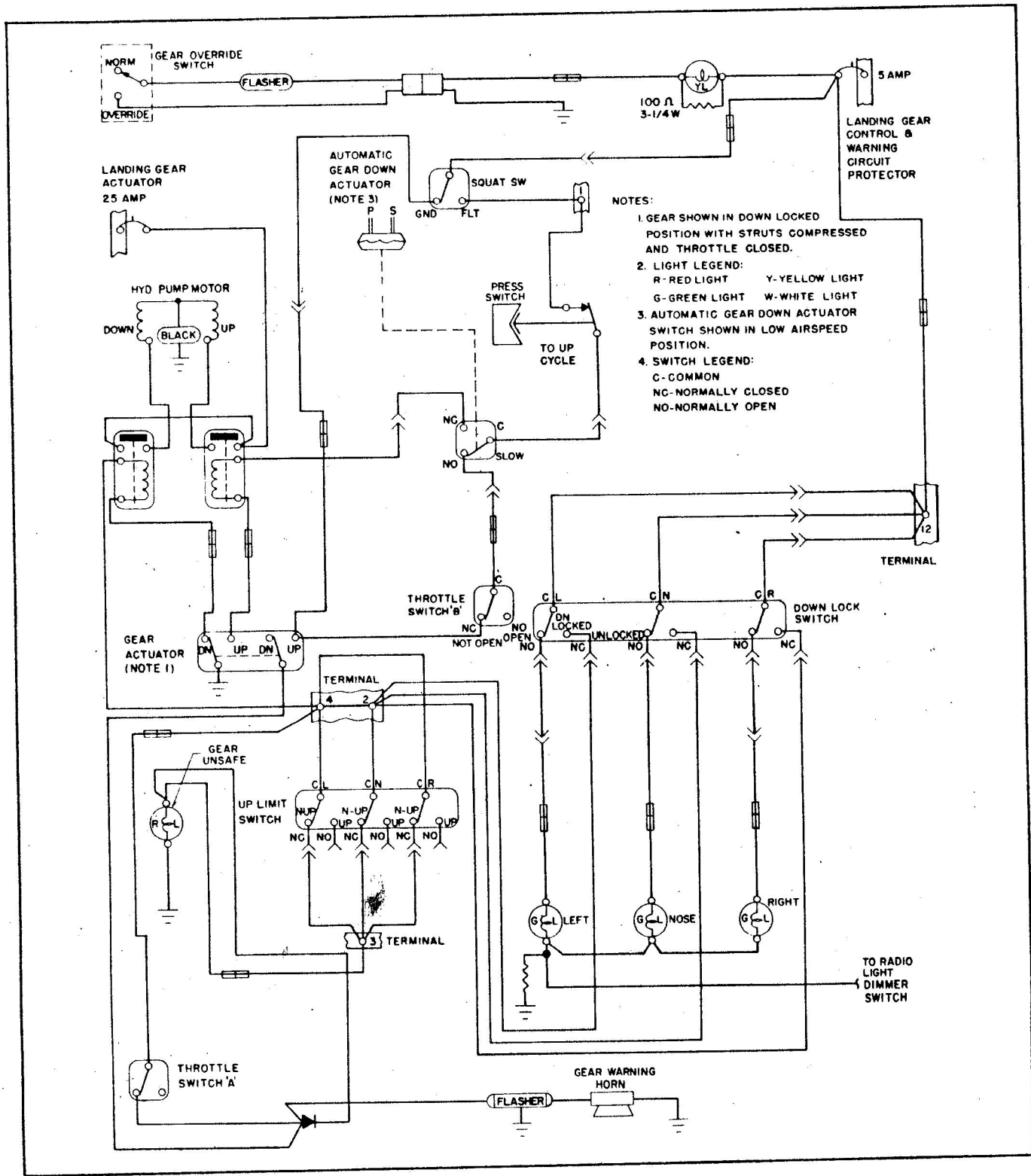

LANDING GEAR ELECTRICAL SCHEMATIC

Figure 7-5

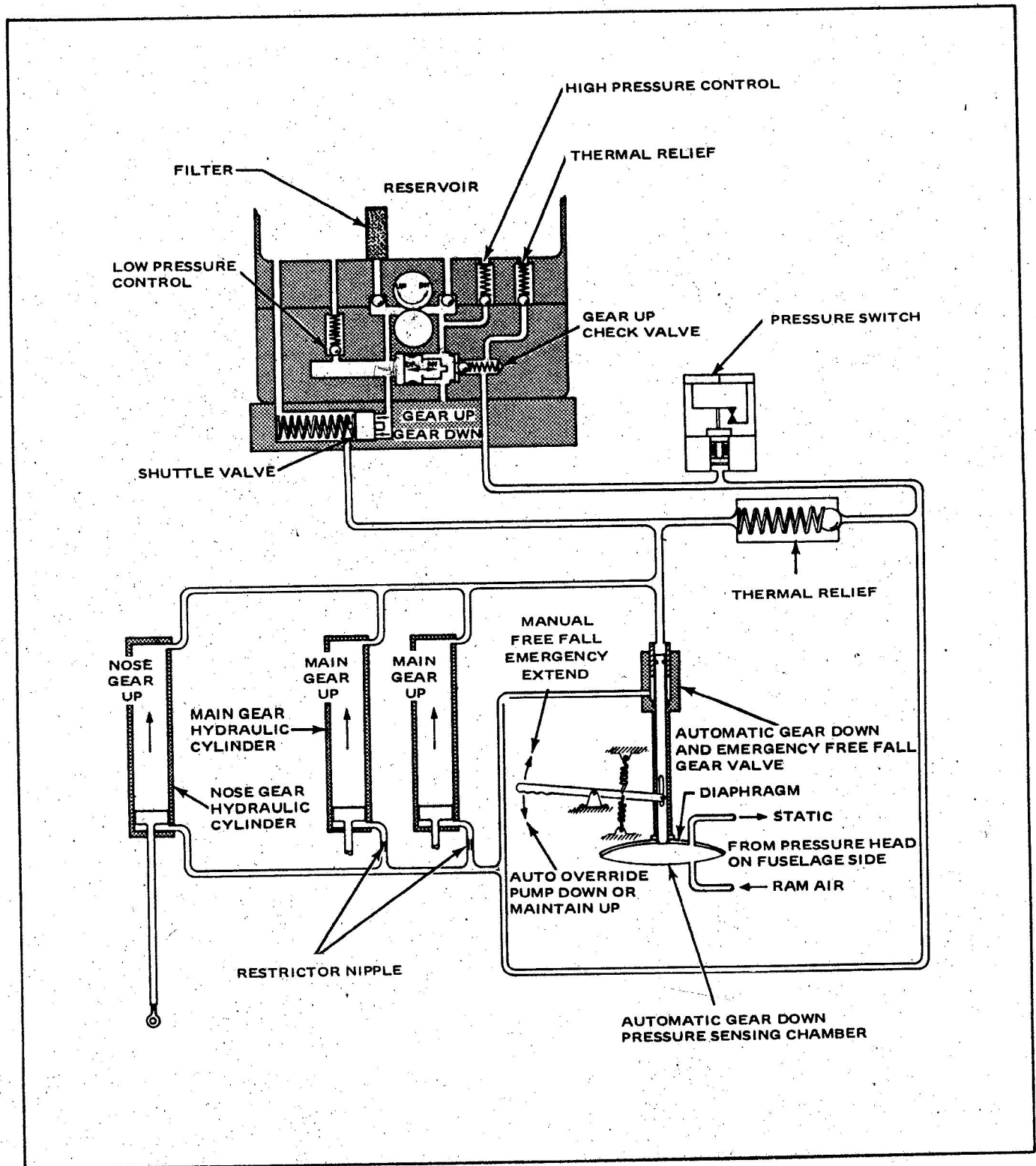

LANDING GEAR HYDRAULIC SYSTEM SCHEMATIC

Figure 7-7

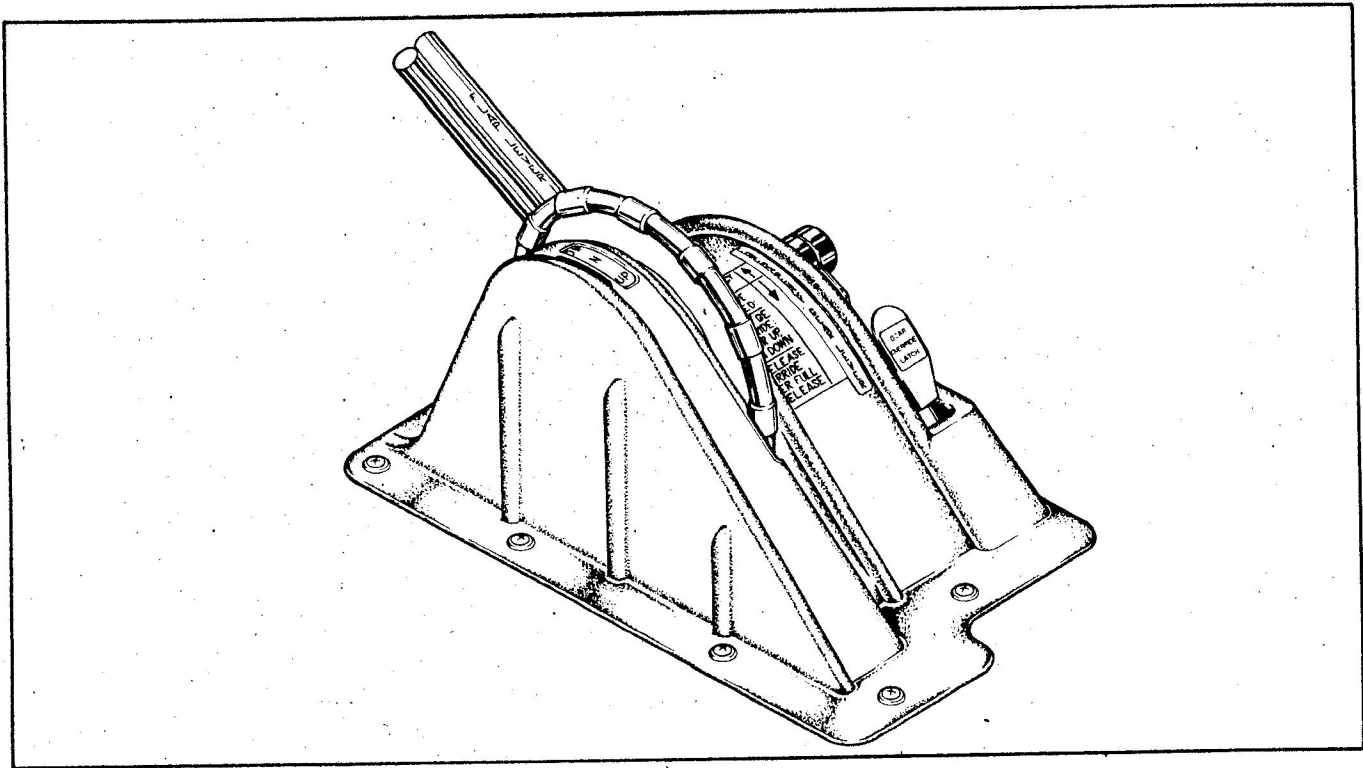

FLIGHT CONTROL CONSOLE

Figure 7-9

7.13 FLIGHT CONTROLS

Dual flight controls are provided as standard equipment. A cable system provides actuation of the control surfaces when the flight controls are moved in their respective directions.

The horizontal surface (stabilator) is of the flying tail design with a trim tab/servo mounted on the trailing edge. This tab serves the dual function of providing trim control and pitch control forces. The trim function is controlled by a trim control wheel located on the control console between the two front seats (Figure 7-9). Rotating the wheel forward gives nose down trim and rotation aft gives nose up trim. The stabilator provides extra stability and controllability with less area, drag and weight than conventional tail surfaces.

The rudder is conventional in design and incorporates a rudder trim. The trim mechanism is a spring-loaded recentering device. The trim control is located on the right side of the pedestal below the throttle quadrant. Turning the trim control clockwise gives nose right trim and counterclockwise rotation gives nose left trim.

Ailerons are provided with differential deflection. This feature reduces adverse yaw in turning maneuvers, and thus reducing the amount of coordination required.

Manually controlled flaps are provided. They are extended by a control cable and are spring-loaded to the retracted (up) position. The control is located between the two front seats on the control console. To extend the flaps pull the handle up to the desired flap setting of 10, 25 or 40 degrees. To retract, depress the button on the end of the handle and lower the control. A balanced control system is used for light operating forces.

When extending or retracting flaps, there is a pitch change in the aircraft. This pitch change can be corrected either by stabilator trim or increased control wheel force. When the flaps are in the retracted position the right flap, provided with a over-center lock mechanism, acts as a step.

NOTE

The right flap will support a load only in the fully retracted (up) position. When loading and unloading passengers make sure the flaps are in the retracted (up) position.

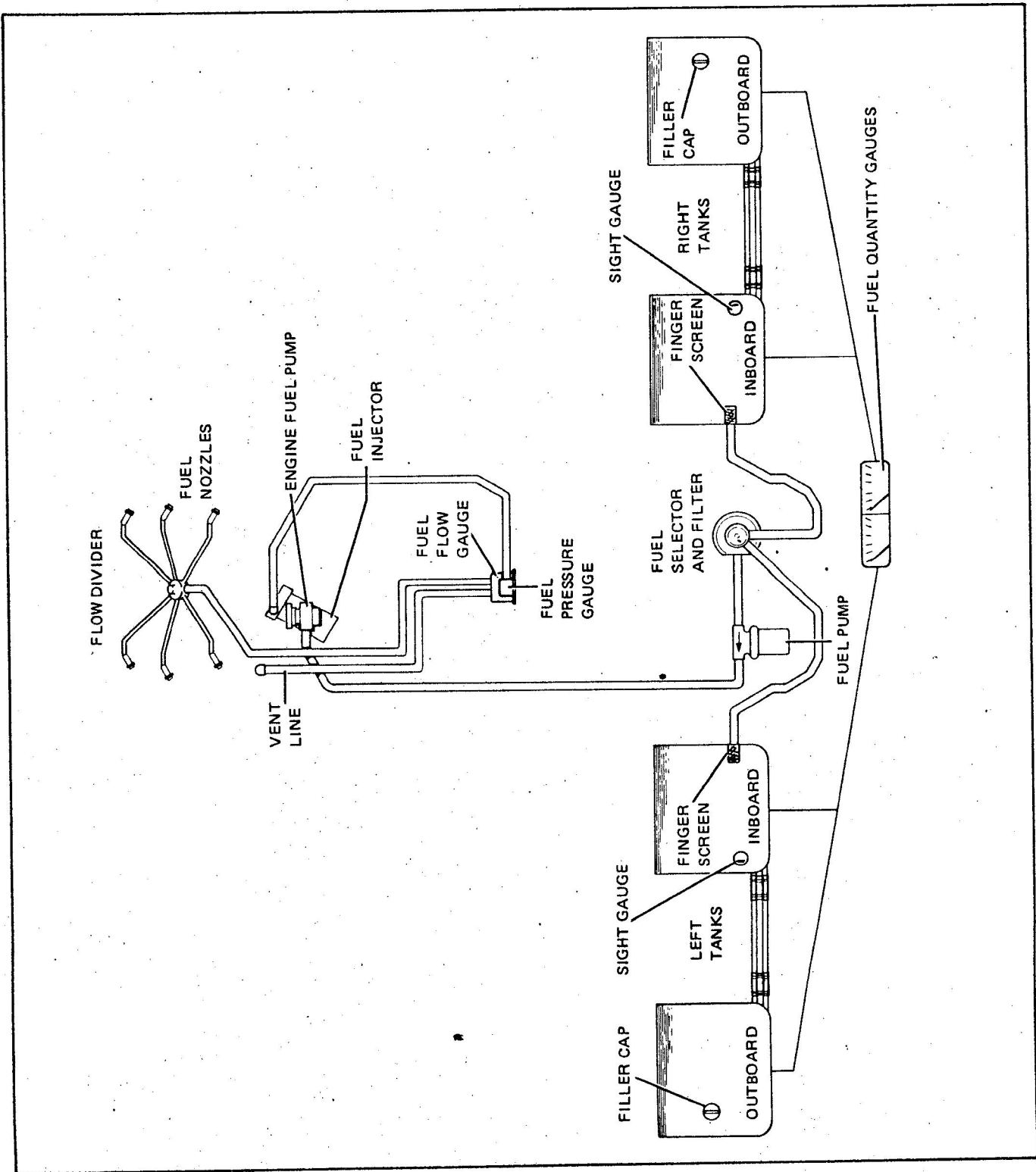

FUEL SYSTEM SCHEMATIC

Figure 7-11

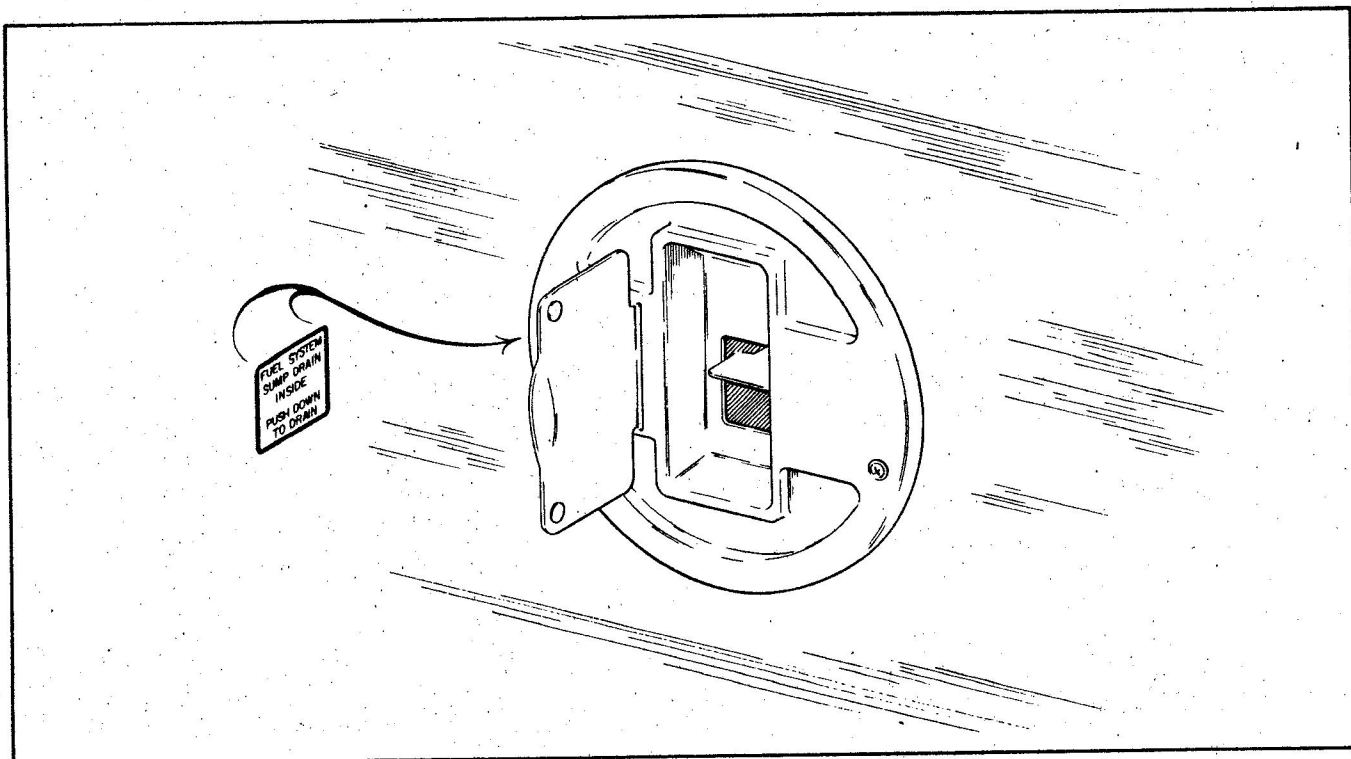

FUEL DRAIN LEVER

Figure 7-13

7.15 FUEL SYSTEM

The standard fuel capacity of the Cherokee Lance is 98 gallons, of which 94 gallons are usable. The tanks are attached to the wing structure with screws and nut plates and can be removed easily for service or inspection.

When using less than the standard 98 gallon capacity of the tanks, fuel should be distributed equally between each side.

The fuel selector control is located below the center of the instrument panel on the sloping face of the control tunnel (refer to Figure 7-1). It has three positions, one position corresponding to each wing tank plus an OFF position.

94

To avoid the accumulation of water and sediment, the fuel system should be drained daily prior to first flight and after refueling. Each tank is equipped with an individual quick drain located at the lower inboard rear corner of the tank. The fuel strainer and a system quick drain valve are located in the fuselage at the lowest point of the fuel system. It is important that the fuel system be drained in the following manner:

1. Drain each tank through its individual quick drain located at the lower inboard rear corner of the tank, making sure that enough fuel has flowed to ensure the removal of all water and sediment.
2. Place a container beneath the fuel sump drain outlet located under the fuselage. A special container is furnished for this operation.
3. Drain the fuel strainer by pressing down on the lever located on the right side of the cabin on the forward edge of the wing spar housing (Figure 7-13). Move the selector through the following sequence: OFF position, left, right, while draining the strainer. Make sure that enough fuel has flowed to drain the fuel line between each tank outlet and the fuel strainer, as well as the strainer itself. With full fuel tanks, it will take approximately 6 seconds to drain all of the fuel from the line from either tank to the fuel strainer. When the tanks are less than full, it will take a few seconds longer.
4. Examine the contents of the container placed under the fuel sump drain outlet. When the fuel flow is free of water and sediment, close the drain and dispose of the contents of the bottle.

CAUTION

When draining fuel, care should be taken to ensure that no fire hazard exists before starting the engine.

After using the underseat quick drain, check from the outside to make sure that it has closed completely and is not leaking.

Fuel quantity gauges for each of the tanks are located in the engine gauge cluster on the left side of the instrument panel. A fuel pressure indicator is also incorporated in the engine gauge cluster.

A fuel quantity indicator to measure the fuel not visible through the filler neck in each wing is installed in the inboard fuel tank. This gauge indicates usable fuel quantities from 5 gallons to 25 gallons in the ground attitude. The sole purpose of this gauge is to assist the pilot in determining fuel quantities of less than 25 gallons during the preflight inspection.

An electric fuel pump is provided for use in case of failure of the engine driven pump. The electric pump operates from a single switch and independent circuit protector. It should be ON for all takeoffs and landings.

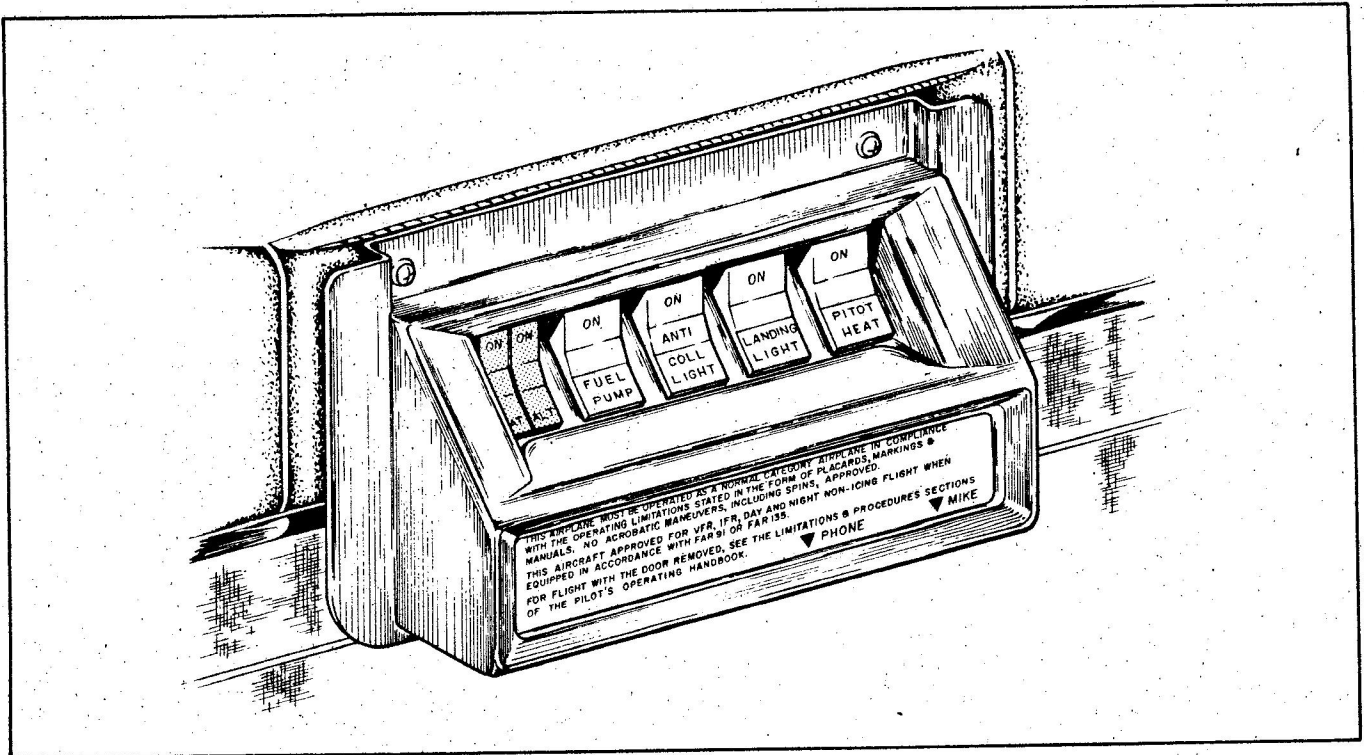

SWITCH PANEL

Figure 7-15

7.17. ELECTRICAL SYSTEM

The 14-volt electrical system includes a 12-volt battery for starting and to back up alternator output. Electrical power is supplied by a 60 ampere alternator. The battery, a master switch relay, a voltage regulator and an overvoltage relay are located beneath the floor of the forward baggage compartment. Access to these electrical components is gained by removing the compartment floor and the access panel located on the left side of the forward fuselage.

Electrical switches are located on a panel to the pilot's left (Figure 7-15) and all circuit breakers are on the lower right instrument panel (refer to Figure 7-19). Two thumb-wheel rheostat switches to the left of the circuit breakers control the navigation lights and the intensity of the instrument panel lights.

Standard electrical accessories include the starter, the electric fuel pump, the stall warning indicator, the cigar lighter, the ammeter, and the annunciator panel.

The annunciator panel includes alternator and low oil pressure indicator lights. When the optional gyro system is installed, the annunciator panel also includes a low vacuum indicator light. The annunciator panel lights are provided only as a warning to the pilot that a system may not be operating properly, and that he should check and monitor the applicable system gauge to determine when or if any necessary action is required.

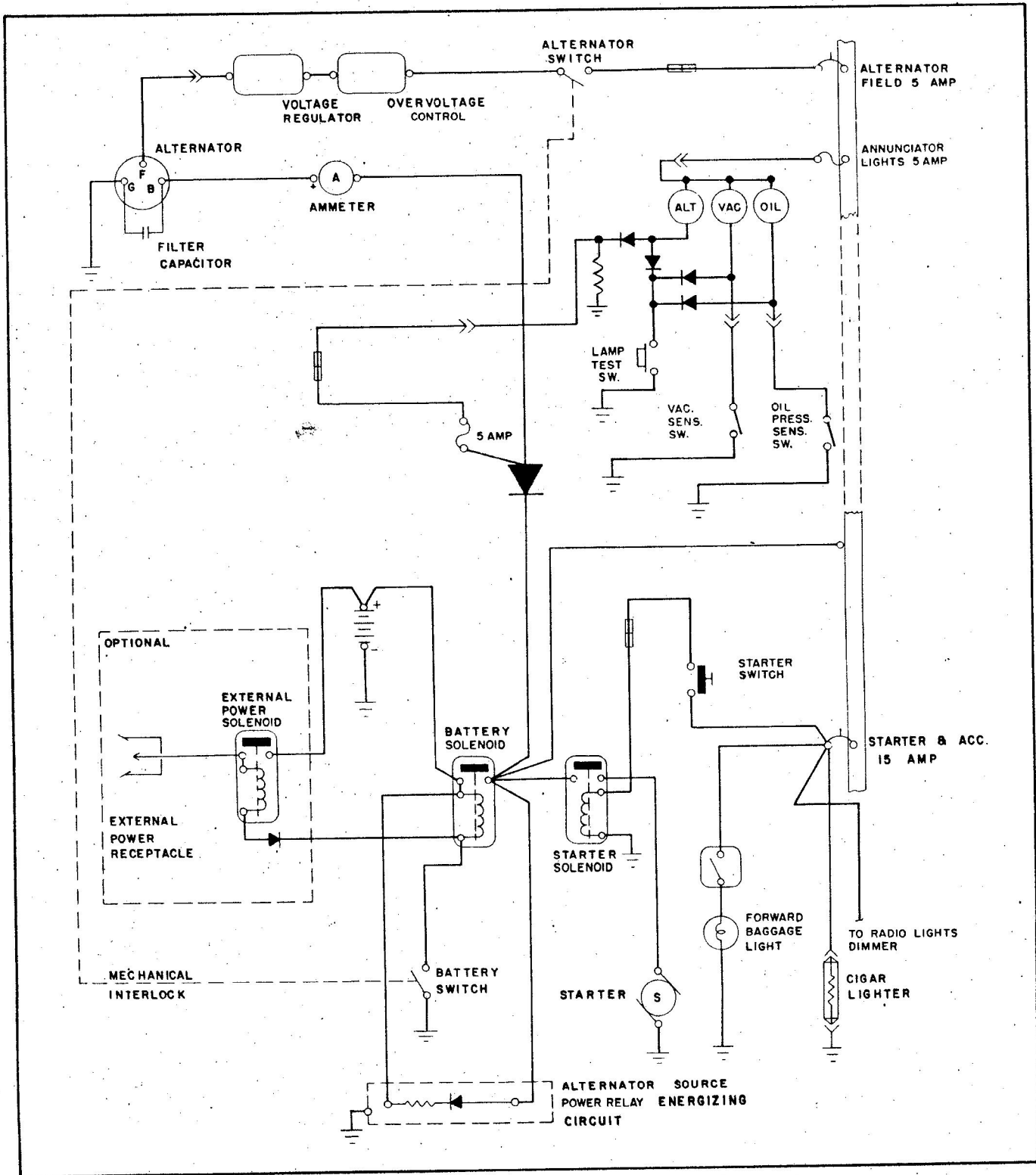

ALTERNATOR AND STARTER SCHEMATIC

Figure 7-17

Optional electrical accessories include the navigation lights, anti-collision strobe lights and instrument panel lighting.

Circuit provisions are made to handle a full complement of communications and navigational equipment.

The alternator system offers many advantages over a generator system. The main advantage is full electrical power output at much lower engine speed, which results in improved radio and electrical equipment operation. Since the alternator output is available all the time, the battery will be charging almost continuously. This will make cold weather starting easier.

The ammeter in the alternator system displays in amperes the load placed on the alternator. It does not indicate battery discharge. With all electrical equipment off (except the master switch) the ammeter will be indicating the amount of charging current demanded by the battery. As each item of electrical equipment is turned on, the current will increase to a total appearing on the ammeter. This total includes the battery. The maximum continuous load for night flight, with radios on, is about 30 amperes. This 30 ampere value, plus approximately 2 amperes for a fully charged battery, will appear continuously under these flight conditions.

The master switch is a split switch with the left half operating the master relay and the right half energizing the alternator. This switch is interlocked so that the alternator cannot be operated without the battery. For normal operation, be sure that both halves are turned on.

Maintenance on the alternator should prove to be a minor factor. Should service be required, contact a Piper Dealer.

WARNINGS

When optional panel lights are installed, radio dimming switch must be off to obtain gear lights full intensity during daytime flying. When aircraft is operated at night and panel light radio dimming switch is turned on, gear lights will automatically dim.

Anti-collision lights should not be operating when flying through clouds, fog or haze, since reflected light can produce spatial disorientation. Strobe lights should not be used in close proximity to the ground, such as during taxiing, takeoff or landing.

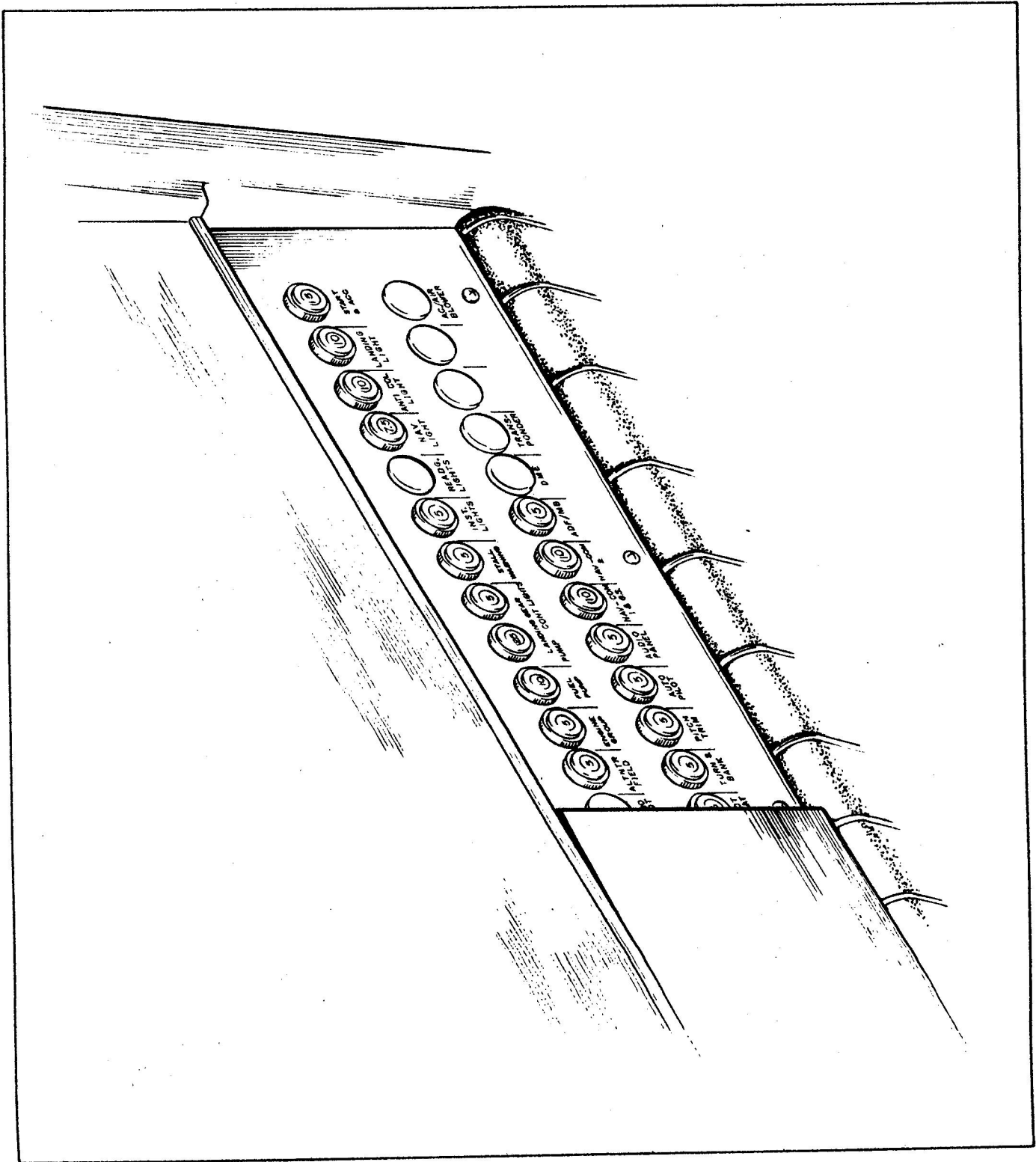

CIRCUIT BREAKER PANEL

Figure 7-19

7.19 VACUUM SYSTEM

The vacuum system is designed to operate the air driven gyro instruments. This includes the directional and attitude gyros when installed. The system consists of an engine driven vacuum pump, a vacuum regulator, a filter and the necessary plumbing.

The vacuum pump is a dry type pump which eliminates the need for an air/oil separator and its plumbing. A shear drive protects the pump from damage. If the drive shears the gyros will become inoperative.

The vacuum gauge, mounted on the right instrument panel to the right of the radios, (refer to Figure 7-21) provides valuable information to the pilot about the operation of the vacuum system. A decrease in pressure in a system that has remained constant over an extended period, may indicate a dirty filter, dirty screens, possibly a sticking vacuum regulator or leak in system (a low vacuum indicator light is provided in the annunciator panel). Zero pressure would indicate a sheared pump drive, defective pump, possibly a defective gauge or collapsed line. In the event of any gauge variation from the norm, the pilot should have a mechanic check the system to prevent possible damage to the system components or eventual failure of the system.

A vacuum regulator is provided in the system to protect the gyros. The valve is set so the normal vacuum reads $5.0 \pm .1$ inches of mercury, a setting which provides sufficient vacuum to operate all the gyros at their rated RPM. Higher settings will damage the gyros and with a low setting the gyros will be unreliable. The regulator is located behind the instrument panel.

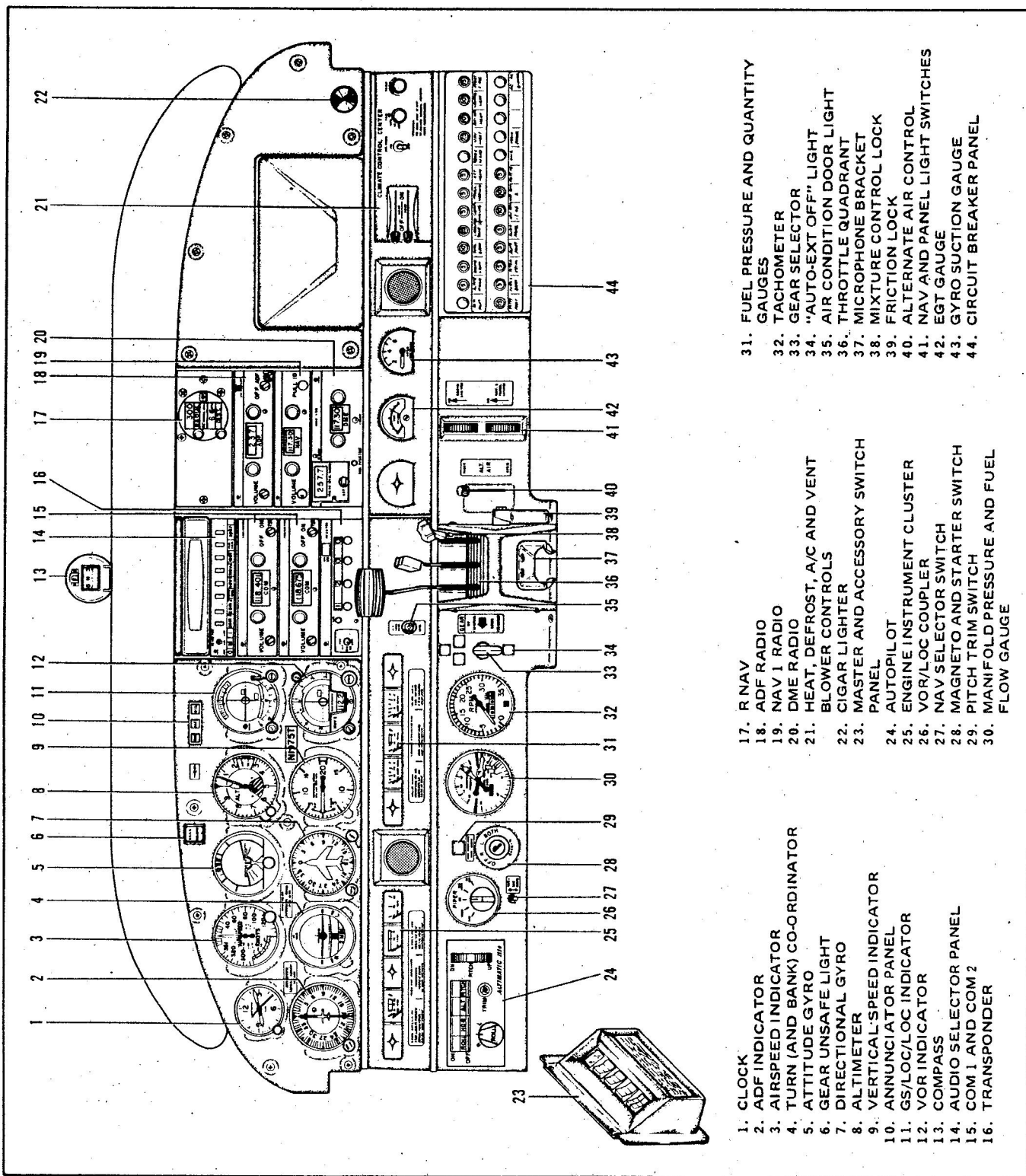

- | | |
|---|--|
| <ul style="list-style-type: none"> 1. CLOCK 2. AIRSPEED INDICATOR 3. TURN (AND BANK) CO-ORDINATOR 4. GEAR UNSAFE LIGHT 5. DIRECTIONAL GYRO 6. ALTITUDE GYRO 7. VERTICAL SPEED INDICATOR 8. ANNUNCIATOR PANEL 9. GS/LOC/LOC INDICATOR 10. VOR INDICATOR 11. COMPASS 12. AUDIO SELECTOR PANEL 13. COM 1 AND COM 2 14. TRANSPONDER 15. R NAV 16. ADF RADIO 17. NAV 1 RADIO 18. DME RADIO 19. HEAT, DEFROST, A/C AND VENT BLOWER CONTROLS 20. CIGAR LIGHTER 21. MASTER AND ACCESSORY SWITCH PANEL 22. AUTOPILOT 23. ENGINE INSTRUMENT CLUSTER 24. VOR/LOC COUPLER 25. NAV SELECTOR SWITCH 26. MAGNETO AND STARTER SWITCH 27. PITCH TRIM SWITCH 28. MANIFOLD PRESSURE AND FUEL FLOW GAUGE 29. FUEL PRESSURE AND QUANTITY GAUGES 30. TACHOMETER 31. GEAR SELECTOR 32. "AUTO-EXT OFF" LIGHT 33. AIR CONDITION DOOR LIGHT 34. THROTTLE QUADRANT 35. MICROPHONE BRACKET 36. MIXTURE CONTROL LOCK 37. FRICTION LOCK 38. ALTERNATE AIR CONTROL 39. NAV AND PANEL LIGHT SWITCHES 40. EGT GAUGE 41. GYRO SUCTION GAUGE 42. CIRCUIT BREAKER PANEL | <ul style="list-style-type: none"> 17. R NAV 18. ADF RADIO 19. NAV 1 RADIO 20. DME RADIO 21. HEAT, DEFROST, A/C AND VENT BLOWER CONTROLS 22. CIGAR LIGHTER 23. MASTER AND ACCESSORY SWITCH PANEL 24. AUTOPILOT 25. ENGINE INSTRUMENT CLUSTER 26. VOR/LOC COUPLER 27. NAV SELECTOR SWITCH 28. MAGNETO AND STARTER SWITCH 29. PITCH TRIM SWITCH 30. MANIFOLD PRESSURE AND FUEL FLOW GAUGE 31. FUEL PRESSURE AND QUANTITY GAUGES 32. TACHOMETER 33. GEAR SELECTOR 34. "AUTO-EXT OFF" LIGHT 35. AIR CONDITION DOOR LIGHT 36. THROTTLE QUADRANT 37. MICROPHONE BRACKET 38. MIXTURE CONTROL LOCK 39. FRICTION LOCK 40. ALTERNATE AIR CONTROL 41. NAV AND PANEL LIGHT SWITCHES 42. EGT GAUGE 43. GYRO SUCTION GAUGE 44. CIRCUIT BREAKER PANEL |
|---|--|

INSTRUMENT PANEL

Figure 7-21

7.21 INSTRUMENT PANEL

The instrument panel of the Cherokee Lance is designed to accommodate the customary advanced flight instruments and the normally required power plant instruments. The artificial horizon and directional gyro are vacuum operated and are located in the center of the left hand instrument panel. The vacuum gauge is located on the right hand instrument panel. The turn indicator, on the left side, is electrically operated.

A natural separation of the flight group and the power group is achieved by the placement of the flight group in the upper instrument panel and the power group in the center and lower instrument panels. The radios are located in the center section of the panel, and the circuit breakers are in the lower right corner of the panel.

An annunciator panel is mounted in the upper instrument panel to warn the pilot of a possible malfunction in the alternator, oil pressure, or vacuum systems.

1. ALTIMETER
2. AIRSPEED INDICATOR
3. PITOT HEAT SWITCH
4. VERTICAL SPEED INDICATOR
5. PITOT HEAD

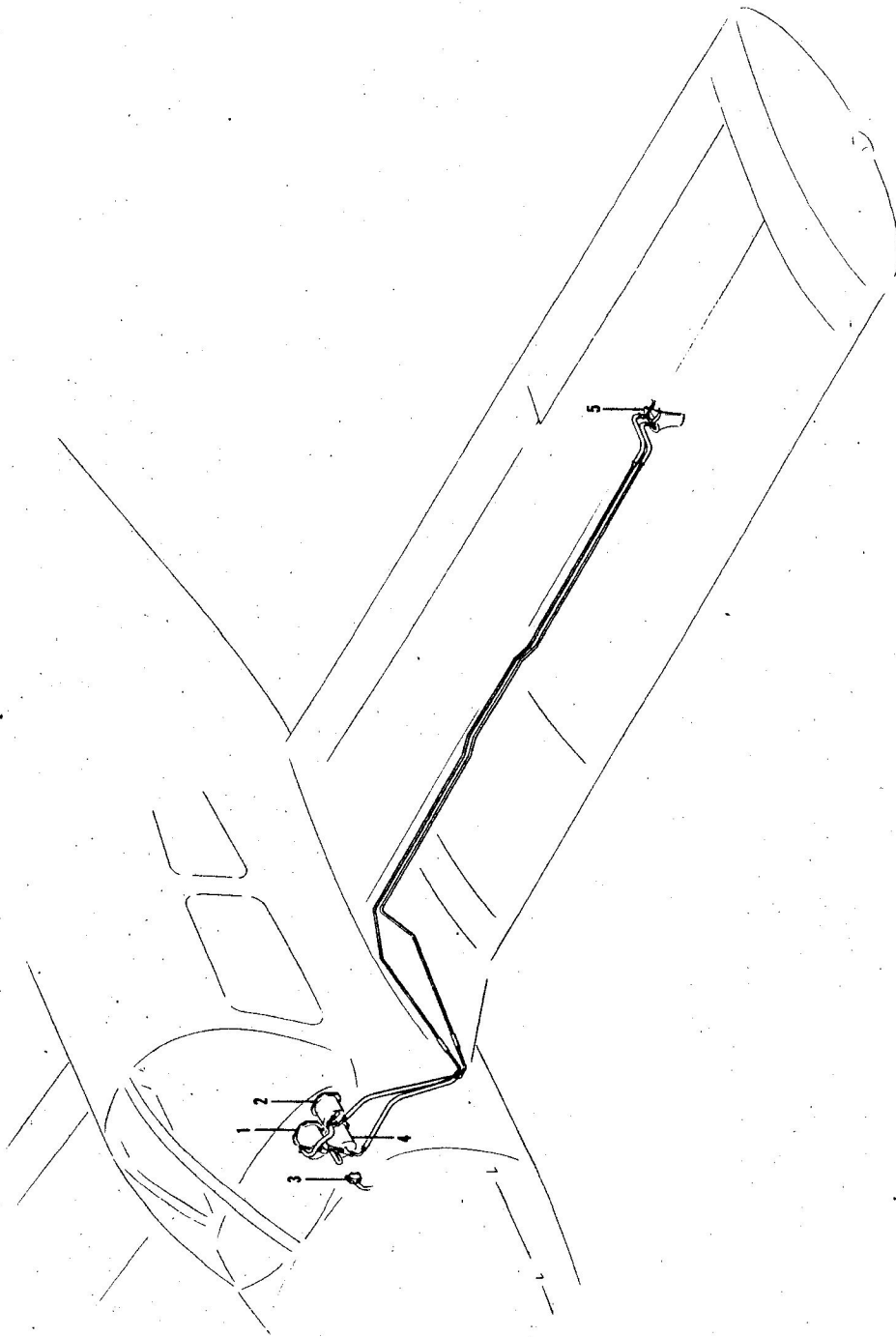

PITOT-STATIC SYSTEM

Figure 7-23

7.23 PITOT-STATIC SYSTEM

The system supplies both pitot and static pressure for the airspeed indicator, altimeter and vertical speed indicator (when installed).

Pitot and static pressure are picked up by the pitot head on the bottom of the left wing. An optional heated pitot head, which alleviates problems with icing or heavy rain, is available. The switch for pitot heat is located on the switch panel to the pilot's left.

To prevent bugs and water from entering the pitot and static pressure holes when the airplane is parked, a cover should be placed over the pitot head. A partially or completely blocked pitot head will give erratic or zero readings on the instruments.

NOTE

During preflight, check to make sure the pitot cover is removed.

7.25 CABIN FEATURES

For ease of entry and exit and for pilot and passenger comfort, the front seats are adjustable fore and aft. All seats recline and have armrests and are available with optional headrests. The front seats can be equipped with optional vertical adjustment. The center and rear seats are easily removed for additional cargo space. Rear seat installations incorporate leg retainers with latching mechanisms which must be released before the rear seats can be removed. Releasing the retainers is easily accomplished by turning the latching mechanisms 90° with a coin or screwdriver. An optional jump seat can be installed between the two middle seats to give the airplane a seven-place capacity.

Single strap shoulder harnesses controlled by inertia reels are standard equipment for the front seats and are offered as optional equipment for the third, fourth, fifth and sixth seats, but not for the seventh seat. The shoulder strap is routed over the shoulder adjacent to the windows and attached to the lap belt in the general area of the person's inboard hip.

The inertia reel should be checked by tugging sharply on the strap. The reel will lock in place under this test and prevent the strap from extending. Under normal movement, the strap will extend and retract as required.

7.27 BAGGAGE AREA

The airplane has two separate baggage areas, each with a 100 pound capacity. A 7 cubic foot forward luggage compartment, located just aft of the fire wall, is accessible through a 16 x 22 inch door on the right side of the fuselage. A 22 cubic foot aft compartment is located behind the fifth and sixth seats and is conveniently accessible through the cargo door on the aft side of the fuselage and even during flight from inside the cabin.

NOTE

It is the pilot's responsibility to be sure when the baggage is loaded that the airplane's C.G. falls within the allowable C.G. range. (Refer to Weight and Balance Section.)

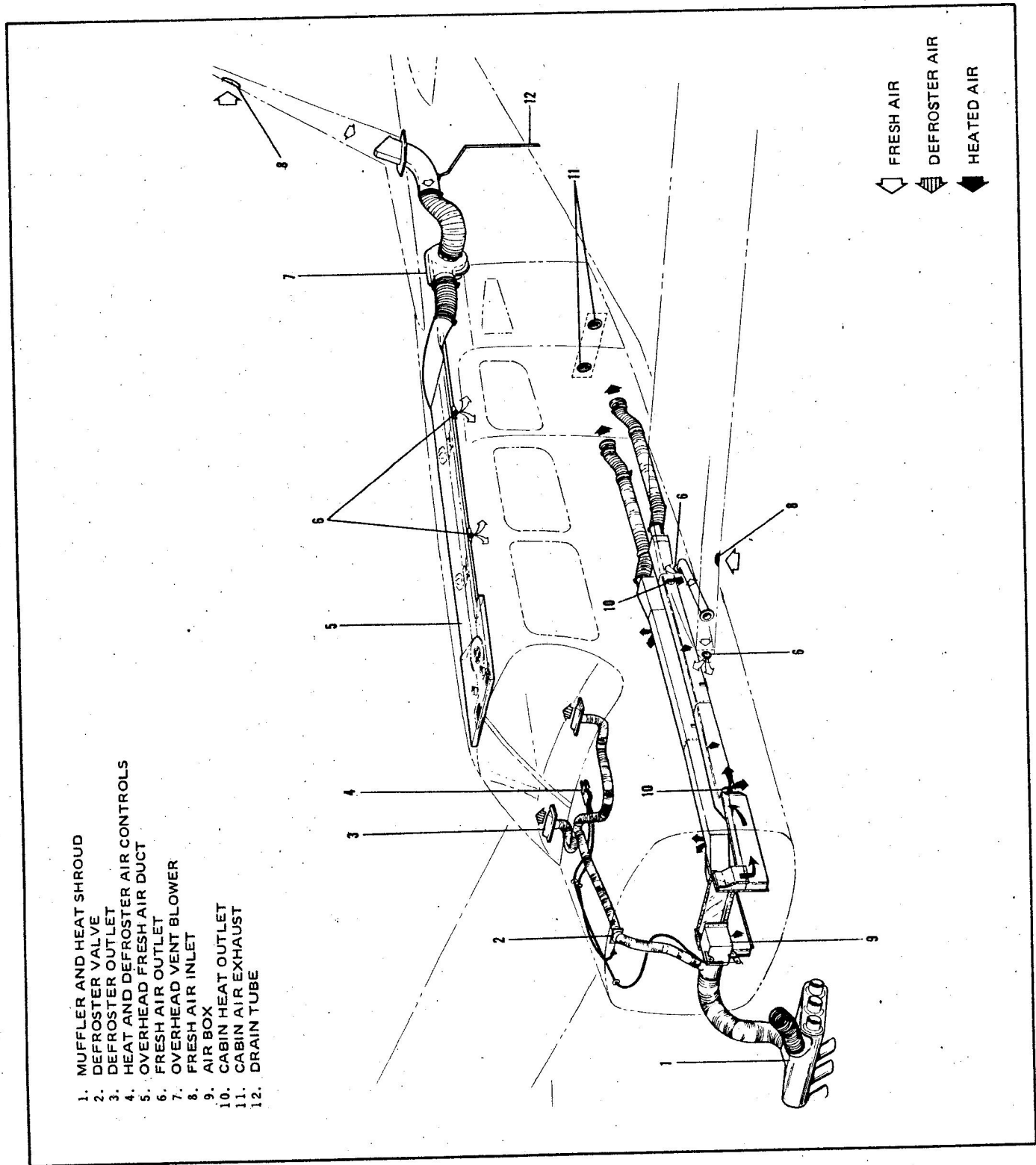

HEATING AND VENTILATING SYSTEM

Figure 7-25

7.29 HEATING AND VENTILATING SYSTEM

Fresh air is ducted from the front left engine baffle to the heater muff by a flexible hose. Hot air from the heater muff is routed through a flexible hose on the right side of the engine compartment, to the valve box mounted on the fire wall just above the tunnel cut out. It is then ducted down each side of the tunnel below the baggage floor to the cabin ducting and outlets (Figure 7-25).

Defrost heat is bled off from the main flow at the valve box and routed through flexible hose to a shut-off valve located to the right of center at the top of the fire wall. From this point, it is ducted to the defroster outlets.

Fresh air inlets are located in the leading edge of each wing at the intersection of the tapered and straight sections, and in the leading edge of the fin. Two large adjustable outlets are located on each side of the cabin, one forward and one aft of the front seat near the floor. There are also adjustable outlets above each seat. In airplanes without air conditioning, an optional blower may be added to the overhead vent system to aid in the circulation of cabin air.

7.31 STALL WARNING

An approaching stall is indicated by a stall warning horn which is activated between five and ten miles per hour above stall speed. Mild airframe buffeting and gentle pitching may also precede the stall. Stall speeds are shown on graphs in the Performance Section. The stall warning horn emits a continuous sound. The landing gear warning horn is different in that it emits a 90 cycle per minute beeping sound. The stall warning horn is activated by a lift detector installed on the leading edge of the left wing. During preflight, the stall warning system should be checked by turning the master switch "ON", lifting the detector and checking to determine if the horn is actuated.

7.33 FINISH

All exterior surfaces are primed with etching primer and finished with acrylic lacquer.

7.35 AIR CONDITIONING*

The air conditioning system is a recirculating air system. The major components include an evaporator, a condenser, a compressor, a blower, switches and temperature controls.

The evaporator is located behind the rear baggage compartment. This cools the air used for the air conditioning system.

The condenser is mounted on a retractable scoop located on the bottom of the fuselage and to the rear of the baggage compartment area. The scoop extends when the air conditioner is ON and retracts to a flush position when the system is OFF.

The compressor is mounted on the forward right underside of the engine. It has an electric clutch which automatically engages or disengages the compressor to the belt drive system of the compressor.

*Optional equipment

Air from the baggage area is drawn through the evaporator by the blower and distributed through an overhead duct to individual outlets located adjacent to each occupant.

The switches and temperature control are located on the lower right side of the instrument panel in the climate control center panel. The temperature control regulates the temperature of the cabin. Turning the control clockwise increases cooling; counterclockwise decreases cooling.

The fan speed switch and the air conditioning ON-OFF switch are inboard of the temperature control. The fan can be operated independently of the air conditioning; however, the fan must be on for air conditioner operation. Turning either switch off will disengage the compressor clutch and retract the condenser door. Cooling air should be felt within one minute after the air conditioner is turned on.

NOTE

If the system is not operating in 5 minutes, turn the system OFF until the fault is corrected.

The fan switch allows operation of the fan with the air conditioner turned OFF to aid in cabin air circulation. "LOW," "MED" or "HIGH" can be selected to direct a flow of air through the air conditioner outlets in the overhead duct. These outlets can be adjusted or turned off individually.

The condenser door light is located to the right of the engine instrument cluster in front of the pilot. The door light illuminates when the door is open and is off when the door is closed.

A circuit breaker on the circuit breaker panel protects the air conditioning electrical system.

Whenever the throttle is in the full forward position, it actuates a micro switch which disengages the compressor and retracts the scoop. This allows maximum power and maximum rate of climb. The fan continues to operate and the air will remain cool for about one minute. When the throttle is retarded approximately 1/4 inch, the clutch will engage, the scoop will extend, and the system will again supply cool, dry air.

7.37 PIPER EXTERNAL POWER*

An optional starting installation known as Piper External Power (PEP) is accessible through a receptacle located on the left side of the nose section aft of the cowling. An external battery can be connected to the socket, thus allowing the operator to crank the engine without having to gain access to the airplane's battery.

*Optional equipment

7.39 EMERGENCY LOCATOR TRANSMITTER*

The Emergency Locator Transmitter (ELT) when installed, is located in the aft portion of the fuselage just below the stabilator leading edge and is accessible through a plate on the right side of the fuselage. This plate is attached with three slotted-head nylon screws for ease of removal; these screws may be readily removed with a variety of common items such as a dime, a key, a knife blade, etc. If there are no tools available in an emergency the screw heads may be broken off by any means. The ELT is an emergency locator transmitter which meets the requirements of FAR 91.52. The unit operates on a self-contained battery. The replacement date as required by FAA regulations is marked on the transmitter label.

The battery should also be replaced if the transmitter has been used in an emergency situation or if accumulated test time exceeds one hour. The unit is equipped with a portable antenna to allow the locator to be removed from the airplane in case of an emergency and used as a portable signal transmitter.

On the unit itself is a three position selector switch placarded "OFF," "ARM" and "ON." The "ARM" position is provided to set the unit to the automatic position so that it will transmit only after impact and will continue to transmit until the battery is drained to depletion or until the switch is manually moved to the "OFF" position. The "ARM" position is selected when the transmitter is installed at the factory and the switch should remain in that position whenever the unit is installed in the airplane. The "ON" position is provided so the unit can be used as a portable transmitter or in the event the automatic feature was not triggered by impact or to periodically test the function of the transmitter.

Select the "OFF" position when changing the battery, when rearming the unit if it has been activated for any reason, or to discontinue transmission.

NOTE

If the switch has been placed in the "ON" position for any reason, the "OFF" position has to be selected before selecting "ARM." If "ARM" is selected directly from the "ON" position, the unit will continue to transmit in the "ARM" position.

A pilot's remote switch, located on the left side panel, is provided to allow the transmitter to be controlled from inside the cabin.

- (a) On some models the pilot's remote switch has three positions and is placarded "ON," "AUTO/ARM," and "OFF/RESET." The switch is normally left in the "AUTO/ARM" position. To turn the transmitter off, move the switch momentarily to the "OFF/RESET" position. The aircraft master switch must be "ON" to turn the transmitter "OFF." To activate the transmitter for tests or other reasons, move the switch upward to the "ON" position and leave it in that position as long as transmission is desired.

*Optional equipment

- (b) On other models the pilot's remote switch has two positions and is placarded "ON/RESET" and "ARM (NORMAL POSITION)." The switch is normally left in the down or "ARM" position. To turn the transmitter off, move the switch to the "ON/RESET" position for one second then return it to the "ARM" position. To activate the transmitter for tests or other reasons, move the switch upward to the "ON/RESET" position and leave it in that position as long as transmission is desired.

The locator should be checked during the ground check to make certain the unit has not been accidentally activated. Check by tuning a radio receiver to 121.5 MHz. If there is an oscillating sound, the locator may have been activated and should be turned off immediately. Reset to the "ARM" position and check again to insure against outside interference.

NOTE

If for any reason a test transmission is necessary, the test transmission should be conducted only in the first five minutes of any hour and limited to three audio sweeps. If tests must be made at any other time, the tests should be coordinated with the nearest FAA tower or flight service station.

TABLE OF CONTENTS

SECTION 8

AIRPLANE HANDLING, SERVICING AND MAINTENANCE

Paragraph No.		Page No.
8.1	General	8-1
8.3	Airplane Inspection Periods	8-3
8.5	Preventive Maintenance	8-4
8.7	Airplane Alterations	8-5
8.9	Ground Handling	8-6
8.11	Engine Air Filter	8-8
8.13	Brake Service	8-8
8.15	Landing Gear Service	8-10
8.17	Propeller Service	8-10
8.19	Oil Requirements	8-11
8.21	Fuel System	8-11
8.23	Tire Inflation	8-12
8.25	Battery Service	8-13
8.27	Cleaning	8-13

REPORT: VB-750

SECTION 8

AIRPLANE HANDLING, SERVICING, AND MAINTENANCE

8.1 GENERAL

This section provides guidelines relating to the handling, servicing, and maintenance of the Cherokee Lance. For complete maintenance instructions, refer to the PA-32R-300 Service Manual.

Every owner should stay in close contact with an authorized Piper Service Center or Piper's Customer Services Department to obtain the latest information pertaining to their airplane, and to avail themselves of Piper Aircraft's support systems.

Piper Aircraft Corporation takes a continuing interest in having owners get the most efficient use from their airplane and keeping it in the best mechanical condition. Consequently, Piper Aircraft, from time to time, issues service releases including Service Bulletins, Service Letters, Service Spares Letters, and others relating to the airplane.

Piper Service Bulletins are of special importance and Piper considers compliance mandatory. These are sent directly to the latest FAA-registered owners in the United States (U.S.) and Piper Service Centers worldwide. Depending on the nature of the release, material and labor allowances may apply. This information is provided to all authorized Piper Service Centers.

Service Letters deal with product improvements and servicing techniques pertaining to the airplane. They are sent to Piper Service Centers and, if necessary, to the latest FAA-registered owners in the U.S. Owners should give careful attention to Service Letter information.

Service Spares Letters offer improved parts, kits, and optional equipment which were not available originally, and which may be of interest to the owner.

Piper Aircraft Corporation offers a subscription service for Service Bulletins, Service Letters, and Service Spares Letters. This service is available to interested persons such as owners, pilots, and mechanics at a nominal fee, and may be obtained through an authorized Piper Service Center or Piper's Customer Services Department.

Maintenance manuals, parts catalogs, and revisions to both, are available from Piper Service Centers or Piper's Customer Services Department.

Any correspondence regarding the airplane should include the airplane model and serial number to ensure proper response.

THIS PAGE INTENTIONALLY LEFT BLANK

8.3 AIRPLANE INSPECTION PERIODS

Piper Aircraft Corporation has developed inspection items and required inspection intervals for the PA-32R (see PA-32R Service and Inspection Manuals). The PA-32R Inspection Manual contains appropriate forms, and all inspection procedures should be complied with by a properly trained, knowledgeable, and qualified mechanic at a Piper Authorized Service Center or a reputable repair shop. Piper Aircraft Corporation cannot accept responsibility for the continued airworthiness of any aircraft not maintained to these standards, and/or not brought into compliance with applicable Service Bulletins issued by Piper Aircraft Corporation, instructions issued by the engine, propeller, or accessory manufacturers, or Airworthiness Directives issued by the FAA.

A Programmed Inspection, approved by the Federal Aviation Administration (FAA), is also available to the owner. This involves routine and detailed inspections to allow maximum utilization of the airplane. Maintenance inspection costs are reduced, and the maximum standard of continued airworthiness is maintained. Complete details are available from Piper Aircraft Corporation.

In addition, but in conjunction with the above, the FAA requires periodic inspections on all aircraft to keep the Airworthiness Certificate in effect. The owner is responsible for assuring compliance with these inspection requirements and for maintaining proper documentation in logbooks and/or maintenance records.

A spectrographic analysis of the engine oil is available from several sources. This inspection, if performed properly, provides a good check of the internal condition of the engine. To be accurate, induction air filters must be cleaned or changed regularly, and oil samples must be taken and sent in at regular intervals.

8.5 PREVENTIVE MAINTENANCE

The holder of a pilot certificate issued under Federal Aviation Regulations (FAR) Part 61 may perform certain preventive maintenance as defined in the FARs. This maintenance may be performed only on an aircraft which the pilot owns and operates, and which is not used in air carrier or air taxi/commercial operations service.

All other aircraft maintenance must be accomplished by a person or facility appropriately certificated by the Federal Aviation Administration (FAA) to perform that work.

Anytime maintenance is accomplished, an entry must be made in the appropriate aircraft maintenance records. The entry shall include:

- (a) The date the work was accomplished.
- (b) Description of the work.
- (c) Number of hours on the aircraft.
- (d) The certificate number of pilot performing the work.
- (e) Signature of the individual doing the work.

8.7 AIRPLANE ALTERATIONS

If the owner desires to have his aircraft modified, he must obtain FAA approval for the alteration. Major alterations accomplished in accordance with Advisory Circular 43.13-2, when performed by an A & P mechanic, may be approved by the local FAA office. Major alterations to the basic airframe or systems not covered by AC 43.13-2 require a Supplemental Type Certificate.

The owner or pilot is required to ascertain that the following Aircraft Papers are in order and in the aircraft.

- (a) To be displayed in the aircraft at all times:
 - (1) Aircraft Airworthiness Certificate Form FAA-8100-2.
 - (2) Aircraft Registration Certificate Form FAA-8050-3.
 - (3) Aircraft Radio Station License if transmitters are installed.

- (b) To be carried in the aircraft at all times:
 - (1) Pilot's Operating Handbook.
 - (2) Weight and Balance data plus a copy of the latest Repair and Alteration Form FAA-337, if applicable.
 - (3) Aircraft equipment list.

Although the aircraft and engine logbooks are not required to be in the aircraft, they should be made available upon request. Logbooks should be complete and up to date. Good records will reduce maintenance cost by giving the mechanic information about what has or has not been accomplished.

8.9 GROUND HANDLING

(a) Towing

The airplane may be moved on the ground by the use of the nose wheel steering bar that is stowed below the forward ledge of the rear baggage compartment or by power equipment that will not damage or excessively strain the nose gear steering assembly. Towing lugs are incorporated as part of the nose gear fork.

CAUTION

When towing with power equipment, do not turn the nose gear beyond its steering radius in either direction, as this will result in damage to the nose gear and steering mechanism.

CAUTION

Do not tow the airplane when the controls are secured.

In the event towing lines are necessary, ropes should be attached to both main gear struts as high up on the tubes as possible. Lines should be long enough to clear the nose and/or tail by not less than fifteen feet, and a qualified person should ride in the pilot's seat to maintain control by use of the brakes.

(b) Taxiing

Before attempting to taxi the airplane, ground personnel should be instructed and approved by a qualified person authorized by the owner. Engine starting and shut-down procedures as well as taxi techniques should be covered. When it is ascertained that the propeller back blast and taxi areas are clear, power should be applied to start the taxi roll, and the following checks should be performed:

- (1) Taxi a few feet forward and apply the brakes to determine their effectiveness.
- (2) Taxi with the propeller set in low-pitch, high RPM setting.
- (3) While taxiing, make slight turns to ascertain the effectiveness of the steering.
- (4) Observe wing clearance when taxiing near buildings or other stationary objects. If possible, station an observer outside the airplane.
- (5) When taxiing over uneven ground, avoid holes and ruts.
- (6) Do not operate the engine at high RPM when running up or taxiing over ground containing loose stones, gravel, or any loose material that may cause damage to the propeller blades.

(c) Parking

When parking the airplane, be sure that it is sufficiently protected from adverse weather conditions and that it presents no danger to other aircraft. When parking the airplane for any length of time or overnight, it is suggested that it be moored securely.

- (1) To park the airplane, head it into the wind if possible.
- (2) Set the parking brake by pulling back on the brake lever and depressing the knob on the handle. To release the parking brake, pull back on the handle until the catch disengages; then allow the handle to swing forward.

CAUTION

Care should be taken when setting brakes that are overheated or during cold weather when accumulated moisture may freeze a brake.

- (3) Aileron and stabilator controls should be secured with the front seat belt and chocks used to properly block the wheels.

(d) Mooring

The airplane should be moored for immovability, security and protection. The following procedures should be used for the proper mooring of the airplane:

- (1) Head the airplane into the wind if possible.
- (2) Retract the flaps.
- (3) Immobilize the ailerons and stabilator by looping the seat belt through the control wheel and pulling it snug.
- (4) Block the wheels.
- (5) Secure tie-down ropes to the wing tie-down rings and to the tail skid at approximately 45 degree angles to the ground. When using rope of non-synthetic material, leave sufficient slack to avoid damage to the airplane should the ropes contract.

CAUTION

Use bowline knots, square knots or locked slip knots. Do not use plain slip knots.

NOTE

Additional preparations for high winds include using tie-down ropes from the landing gear forks and securing the rudder.

- (6) Install a pitot head cover if available. Be sure to remove the pitot head cover before flight.
- (7) Cabin and baggage doors should be locked when the airplane is unattended.

8.11 ENGINE AIR FILTER

(a) Removing Engine Air Filter

- (1) Remove the access door on left side of lower cowl.
- (2) Remove the wing nuts securing the filter. Remove the filter.

(b) Cleaning Engine Air Filter

The injector air filter must be cleaned at least once every 50 hours, and more often, even daily, when operating in dusty conditions. Extra filters are inexpensive, and a spare should be kept on hand for use as a rapid replacement.

To clean the filter:

- (1) Tap the filter gently to remove dirt particles, being careful not to damage the filter. DO NOT wash the filter in any liquid. DO NOT attempt to blow out dirt with compressed air.
- (2) If the filter is excessively dirty or shows any damage, replace it immediately.
- (3) Wipe the filter housing with a clean cloth soaked in unleaded gasoline. When the housing is clean and dry, install the filter.

(c) Installation Of Engine Air Filter

After cleaning or when replacing the filter, install the filter in the reverse order of removal.

8.13 BRAKE SERVICE

The brake system is filled with MIL-H-5606 (petroleum base) hydraulic brake fluid. The fluid level should be checked periodically or at every 100 hour inspection and replenished when necessary. The brake reservoir is located on the left side of the fire wall in the engine compartment. If the entire system must be refilled, fill with fluid under pressure from the brake end of the system. This will eliminate air from the system.

No adjustment of the brake clearances is necessary. If after extended service brake blocks become excessively worn, they should be replaced with new segments.

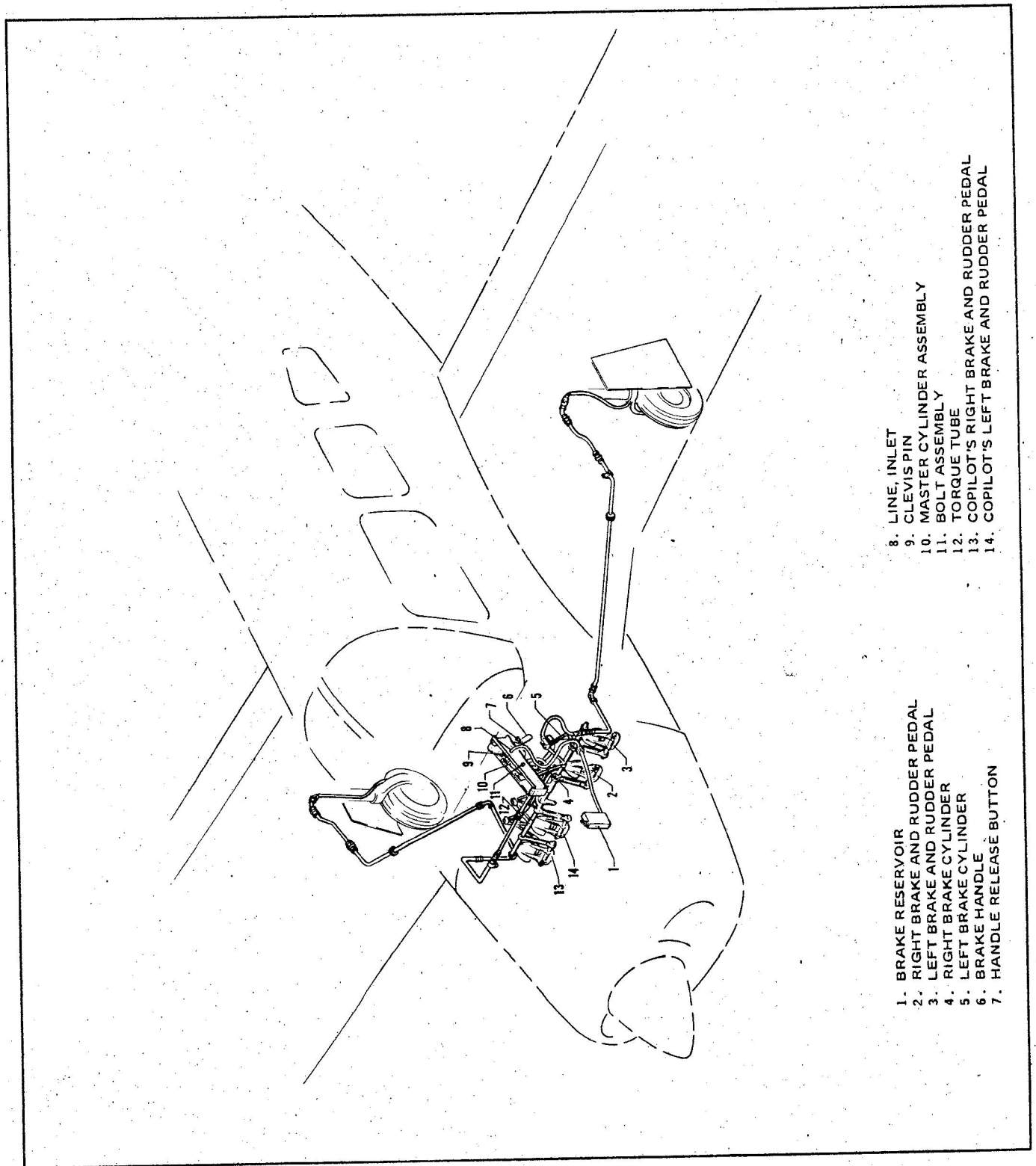

BRAKE SYSTEM

Figure 8-1

8.15 LANDING GEAR SERVICE

The main landing gear uses Cleveland Aircraft Products 6.00 x 6 wheels with 6.00 x 6, eight-ply rating tires and tubes. The nose wheel uses a Cleveland Aircraft Products 5.00 x 5 wheel with a 5.00 x 5 six-ply rating, type III tire and tube. (Refer to paragraph 8.23.)

Wheels are removed by taking off the hub cap, cotter pin, axle nut, and the two bolts holding the brake segment in place. Mark tire and wheel for reinstallation; then dismount by deflating the tire, removing the three through-bolts from the wheel and separating the wheel halves.

Landing gear oleos on the Cherokee Lance should be serviced according to the instructions on the units. The main oleos should be extended under normal static load until $4.0 \pm .25$ inches of oleo piston tube is exposed, and the nose gear should show $2.60 \pm .25$ inches. To add air to the oleo struts, attach a strut pump to the valve assembly near the top of the oleo strut housing and pump the oleo to the desired position. To add oil, jack the aircraft, release the air pressure in the strut, remove the valve core and add oil through this opening with the strut extended. After the strut is full, compress it slowly and fully to allow excess air and oil to escape. With the strut still compressed reinsert the valve stem and pump up the strut as above.

In jacking the aircraft for landing gear or other service, two hydraulic jacks and a tail stand should be used. At least 250 pounds of ballast should be placed on the base of the tail stand before the airplane is jacked up. The hydraulic jacks should be placed under the jack points on the bottom of the wing and the airplane jacked up until the tail skid is at the right height to attach the tail stand. After the tail stand is attached and the ballast added, jacking may be continued until the airplane is at the height desired.

The steering arms from the rudder pedals to the nose wheel are adjusted at the rudder pedals or at the nose wheel by turning the threaded rod end bearings in or out. Adjustment is normally accomplished at the forward end of the rods and should be done in such a way that the nose wheel is in line with the fore and aft axis of the plane when the rudder pedals and rudder are centered. Alignment of the nose wheel can be checked by pushing the airplane back and forth with the rudder centered to determine that the plane follows a perfectly straight line. The turning arc of the nose wheel is $22.5^\circ \pm 2^\circ$ in either direction and is limited by stops at the rudder pedals.

8.17 PROPELLER SERVICE

The spinner and backing plate should be cleaned and inspected for cracks frequently. Before each flight the propeller should be inspected for nicks, scratches, and corrosion. If found, they should be repaired as soon as possible by a rated mechanic, since a nick or scratch causes an area of increased stress which can lead to serious cracks or the loss of a propeller tip. The back face of the blades should be painted when necessary with flat black paint to retard glare. To prevent corrosion, the surface should be cleaned and waxed periodically.

8.19 OIL REQUIREMENTS

The oil capacity of the Lycoming IO-540 series engine is 12 quarts, and the minimum safe quantity is 2-3/4 quarts. It is recommended that engine oil be drained and renewed every 50 hours. The oil filter element should be changed every 50 hours of operation. The interval between oil and oil filter changes should not exceed a total of four (4) months. Under unfavorable dusty conditions, the oil and oil filter should be changed more frequently.

The following seasonal aviation oil grades and seasonal ambient temperature ranges are recommended.

<u>Average Ambient Temperature</u>	<u>MIL-L-6082B Mineral SAE Grade</u>	<u>MIL-L-22851 Ashless Dispersant SAE Grades</u>
All Temperatures	--	15W-50 or 20W-50
Above 80°F	60	60
Above 60°F	50	40 or 50
30°F to 90°F	40	40
0°F to 70°F	30	30, 40 or 20W-40
0°F to 90°F	20W-50	20W-50 or 15W-50
Below 10°F	20	30 or 20W-30

When operating temperatures overlap indicated ranges, use the lighter grade oil.

NOTE

Refer to the latest issue of Textron Lycoming Service Instruction 1014 (Lubricating Oil Recommendations) for further information.

8.21 FUEL SYSTEM

(a) Servicing Fuel System

At every 50 hour inspection, the fuel screens in the strainer and in the injector must be cleaned. The screen in the injector is located in the housing where the fuel line connects to the injector. The fuel strainer is located under the floor panel and is accessible for cleaning through an access plate on the underside of the fuselage. After cleaning, a small amount of grease applied to the gasket will facilitate reassembly.

(b) Fuel Requirements (AVGAS ONLY)

Aviation grade fuel with a minimum octane of 100/130 must be used in this airplane. Since the use of lower grades can cause serious engine damage in a short period of time, the engine warranty is invalidated by the use of lower octanes.

(c) Filling Fuel Tanks

Observe all safety precautions required when handling gasoline. Fill the fuel tanks through the filler located on the forward slope of the wing. Each wing holds a maximum of 49 U.S. gallons. When using less than the standard 98 gallon capacity, fuel should be distributed equally between each side.

(c) Draining Fuel Valves and Lines

The fuel system should be drained before the first flight of the day and after refueling to avoid the accumulation of water and sediment. Each fuel tank has an individual quick drain at the lower inboard corner. A fuel strainer with a fuel system quick drain is located at the lowest point in the system. Each tank should be drained through its individual quick drain until sufficient fuel has flowed to ensure the removal of any contaminants. The fuel system quick drain, operated by a lever inside the cabin on the right forward edge of the wing spar housing, should be opened while the fuel selector valve is moved through the two tank positions. Enough fuel should flow at each position to allow the fuel lines and the strainer to clear. A container is provided for the checking of fuel clarity. (See Description - Airplane and Systems Section for more detailed instructions.)

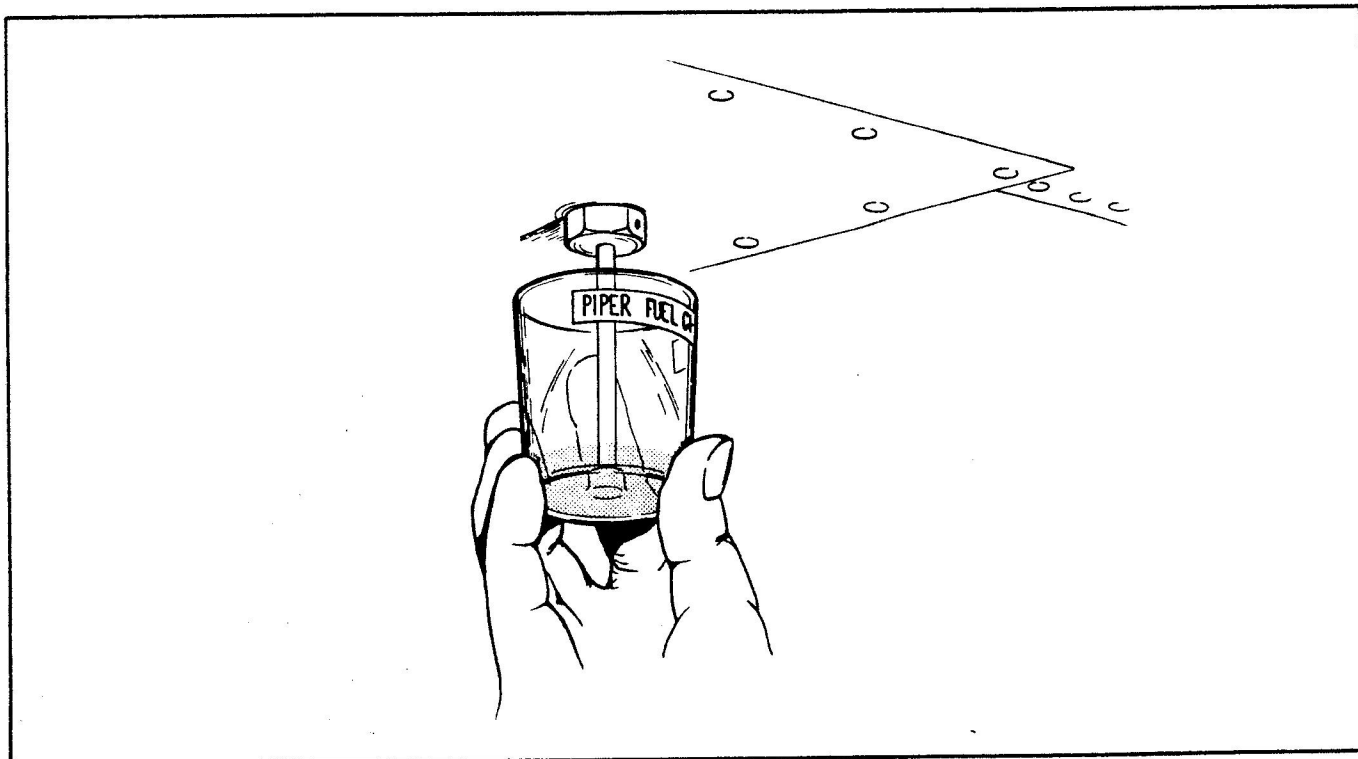

FUEL DRAIN

Figure 8-3

CAUTION

When draining fuel, be sure that no fire hazard exists before starting the engine.

After using the fuel system quick drain, check from outside the airplane to be sure that it has closed completely and is not leaking.

(e) Draining Fuel System

The bulk of the fuel may be drained by opening the individual drain on each tank. The remaining fuel may be drained through the fuel strainer.

8.23 TIRE INFLATION

For maximum service from the tires, keep them inflated to the proper pressures - 35 psi for the nose gear and 38 psi for the main gear. All wheels and tires are balanced before original installation, and the relationship of tire, tube, and wheel should be maintained upon reinstallation. Unbalanced wheels can cause extreme vibration in the landing gear; therefore, in the installation of new components, it may be necessary to rebalance the wheels with the tires mounted. When checking tire pressure, examine the tires for wear, cuts, bruises, and slippage.

8.25 BATTERY SERVICE

Access to the 12-volt battery is through an access panel in the left side of the fuselage and through a removable panel in the floor of the forward baggage compartment. The battery box has a plastic tube which is normally closed off with a cap and which should be opened occasionally to drain off any accumulation of liquid. The battery should be checked for proper fluid level. DO NOT fill the battery above the baffle plates. DO NOT fill the battery with acid - use water only. A hydrometer check will determine the percent of charge in the battery.

If the battery is not up to charge, recharge starting at a 4 amp rate and finishing with a 2 amp rate. Quick charges are not recommended.

8.27 CLEANING

(a) Cleaning Engine Compartment

Before cleaning the engine compartment, place a strip of tape on the magneto vents to prevent any solvent from entering these units.

- (1) Place a large pan under the engine to catch waste.
- (2) With the engine cowling removed, spray or brush the engine with solvent or a mixture of solvent and degreaser. In order to remove especially heavy dirt and grease deposits, it may be necessary to brush areas that were sprayed.

CAUTION

Do not spray solvent into the alternator, vacuum pump, starter, or air intakes.

- (3) Allow the solvent to remain on the engine from five to ten minutes. Then rinse the engine clean with additional solvent and allow it to dry.

CAUTION

Do not operate the engine until excess solvent has evaporated or otherwise been removed.

- (4) Remove the protective tape from the magnetos.
- (5) Lubricate the controls, bearing surfaces, etc., in accordance with the Lubrication Chart.

(b) Cleaning Landing Gear

Before cleaning the landing gear, place a plastic cover or similar material over the wheel and brake assembly.

- (1) Place a pan under the gear to catch waste.
- (2) Spray or brush the gear area with solvent or a mixture of solvent and degreaser, as desired. Where heavy grease and dirt deposits have collected, it may be necessary to brush areas that were sprayed, in order to clean them.
- (3) Allow the solvent to remain on the gear from five to ten minutes. Then rinse the gear with additional solvent and allow to dry.
- (4) Remove the cover from the wheel and remove the catch pan.
- (5) Lubricate the gear in accordance with the Lubrication Chart.
- (6) Caution: Do not brush the micro switches.

(c) Cleaning Exterior Surfaces

The airplane should be washed with a mild soap and water. Harsh abrasives or alkaline soaps or detergents could make scratches on painted or plastic surfaces or could cause corrosion of metal. Cover areas where cleaning solution could cause damage. To wash the airplane, use the following procedure:

- (1) Flush away loose dirt with water.
- (2) Apply cleaning solution with a soft cloth, a sponge or a soft bristle brush.
- (3) To remove exhaust stains, allow the solution to remain on the surface longer.
- (4) To remove stubborn oil and grease, use a cloth dampened with naphtha.
- (5) Rinse all surfaces thoroughly.
- (6) Any good automotive wax may be used to preserve painted surfaces. Soft cleaning cloths or a chamois should be used to prevent scratches when cleaning or polishing. A heavier coating of wax on the leading surfaces will reduce the abrasion problems in these areas.

(d) Cleaning Windshield and Windows

- (1) Remove dirt, mud and other loose particles from exterior surfaces with clean water.
- (2) Wash with mild soap and warm water or with aircraft plastic cleaner. Use a soft cloth or sponge in a straight back and forth motion. Do not rub harshly.
- (3) Remove oil and grease with a cloth moistened with kerosene.

CAUTION

Do not use gasoline, alcohol, benzene, carbon tetrachloride, thinner, acetone, or window cleaning sprays.

- (4) After cleaning plastic surfaces, apply a thin coat of hard polishing wax. Rub lightly with a soft cloth. Do not use a circular motion.
- (5) A severe scratch or mar in plastic can be removed by rubbing out the scratch with jeweler's rouge. Smooth both sides and apply wax.

(e) Cleaning Headliner, Side Panels and Seats

- (1) Clean headliner, side panels, and seats with a stiff bristle brush, and vacuum where necessary.
- (2) Soiled upholstery, except leather, may be cleaned with a good upholstery cleaner suitable for the material. Carefully follow the manufacturer's instructions. Avoid soaking or harsh rubbing.

CAUTION

Solvent cleaners require adequate ventilation.

- (3) Leather should be cleaned with saddle soap or a mild hand soap and water.

(f) Cleaning Carpets

To clean carpets, first remove loose dirt with a whisk broom or vacuum. For soiled spots and stubborn stains use a noninflammable dry cleaning fluid. Floor carpets may be removed and cleaned like any household carpet.

THIS PAGE INTENTIONALLY LEFT BLANK

TABLE OF CONTENTS

SECTION 9

SUPPLEMENTS

Paragraph/Supplement No.		Page No.
9.1	General	9-1
1	Air Conditioning System Installation	9-3
2	AutoFlite II Autopilot Installation	9-7
3	AutoControl IIIB Autopilot Installation	9-9
4	AltiMatic IIIC Autopilot Installation	9-13
5	Piper Electric Pitch Trim	9-19

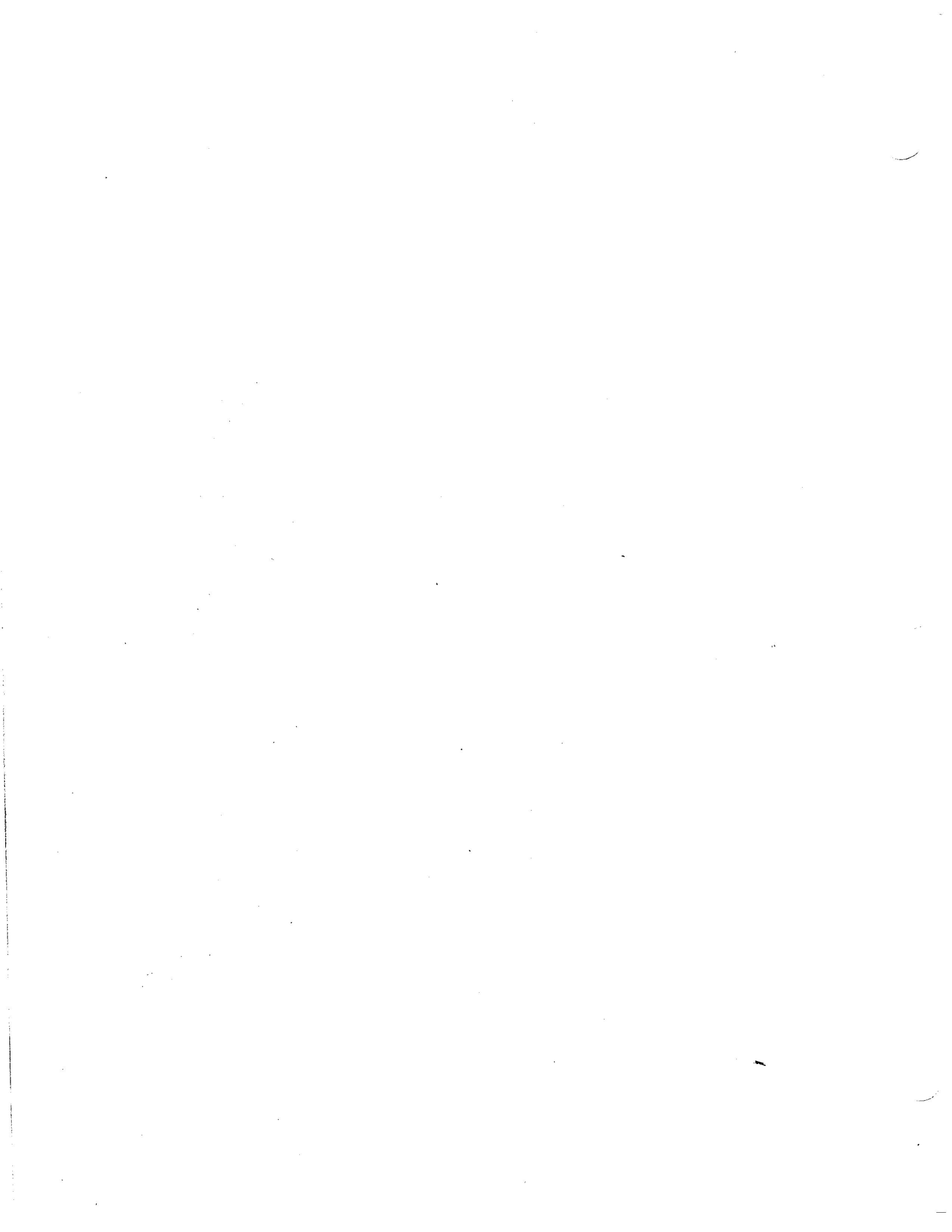

**SECTION 9
SUPPLEMENTS**

9.1 GENERAL

This section provides information in the form of Supplements which are necessary for efficient operation of the airplane when equipped with one or more of the various optional systems and equipment not provided with the standard airplane.

All of the Supplements provided by this section are "FAA Approved" and consecutively numbered as a permanent part of this Handbook. The information contained in each Supplement applies only when the related equipment is installed in the airplane.

THIS PAGE INTENTIONALLY LEFT BLANK

SUPPLEMENT 1

AIR CONDITIONING INSTALLATION

SECTION 1 - GENERAL

This supplement supplies information necessary for the efficient operation of the airplane when the optional air conditioning system is installed. The information contained within this supplement is to be used "as described" in conjunction with the complete handbook.

This supplement has been "FAA Approved" as a permanent part of this handbook and must remain in this handbook at all times when the optional air conditioning system is installed.

SECTION 2 - LIMITATIONS

- (a) To insure maximum climb performance the air conditioner must be turned "OFF" manually prior to takeoff to disengage the compressor and retract the condenser door. Also the air conditioner must be turned "OFF" manually before the landing approach in preparation for a possible go-around.
- (b) Placards
In full view of the pilot, in the area of the air conditioner controls when the air conditioner is installed:

"WARNING - AIR CONDITIONER MUST BE OFF TO INSURE
NORMAL TAKEOFF CLIMB PERFORMANCE."

In full view of the pilot, to the right of the engine gauges (condenser door light):

"AIR COND DOOR
OPEN"

SECTION 3 - EMERGENCY PROCEDURES

No changes to the basic Emergency Procedures provided by Section 3 of this Pilot's Operating Handbook are necessary for this supplement.

SECTION 4 - NORMAL PROCEDURES

Prior to takeoff, the air conditioner should be checked for proper operation as follows:

- (a) Check aircraft master switch "ON."
- (b) Turn the air conditioner control switch to "ON" and the fan switch to one of the operating positions - the "AIR COND DOOR OPEN" warning light will turn on, thereby indicating proper air conditioner condenser door actuation.
- (c) Turn the air conditioner control switch to "OFF" - the "AIR COND DOOR OPEN" warning light will go out, thereby indicating the air conditioner condenser door is in the up position.
- (d) If the "AIR COND DOOR OPEN" light does not respond as specified above, an air conditioner system or indicator bulb malfunction is indicated and further investigation should be conducted prior to flight.

The above operational check may be performed during flight if an in flight failure is suspected.

The condenser door light is located to the right of the engine instrument cluster in front of the pilot. The door light illuminates when the door is open and is off when the door is closed.

SECTION 5 - PERFORMANCE

Operation of the air conditioner will cause slight decreases in cruise speed and range. Power from the engine is required to run the compressor, and the condenser door, when extended, causes a slight increase in drag. When the air conditioner is turned off there is normally no measurable difference in climb, cruise or range performance of the airplane.

NOTE

To insure maximum climb performance the air conditioner must be turned off manually before takeoff to disengage the compressor and retract the condenser door. Also the air conditioner must be turned off manually before the landing approach in preparation for a possible go-around.

Although the cruise speed and range are only slightly affected by the air conditioner operation, these changes should be considered in preflight planning. To be conservative, the following figures assume that the compressor is operating continuously while the airplane is airborne. This will be the case only in extremely hot weather.

- (a) The decrease in true airspeed is approximately 7 mph at all power settings.
- (b) The decrease in range may be as much as 50 statute miles for the 94 gallon capacity.

The climb performance is not compromised measurably with the air conditioner operating since the compressor is declutched and the condenser door is retracted, both automatically, when a full throttle position is selected. When the full throttle position is not used or in the event of a malfunction which would cause the compressor to operate and the condenser door to be extended, a decrease in rate of climb of as much as 100 fpm can be expected. Should a malfunction occur which prevents condenser door retraction when the compressor is turned off, a decrease in rate of climb of as much as 50 fpm can be expected.

THIS PAGE INTENTIONALLY LEFT BLANK

SUPPLEMENT 2

AUTOFLITE II AUTOPILOT INSTALLATION

SECTION 1 - GENERAL

This supplement supplies information necessary for the operation of the airplane when the optional AutoFlite II Autopilot is installed. The information contained within this supplement is to be used "as described" in conjunction with the complete handbook.

This supplement has been "FAA Approved" as a permanent part of this handbook and must remain in this handbook at all times when the optional AutoFlite II Autopilot is installed.

SECTION 2 - LIMITATIONS

- (a) Autopilot operation prohibited above 200 MPH CAS. (Autopilot Vmo)
- (b) Autopilot must be "OFF" for takeoff and landing.

SECTION 3 - EMERGENCY PROCEDURES

- (a) In case of malfunction, PRESS disconnect switch on pilot's control wheel.
- (b) In case of malfunction, overpower autopilot at either control wheel.
- (c) AutoFlite II master switch - OFF.
- (d) In climb, cruise or descent configuration a malfunction with a 3 second delay in recovery initiation may result in 50° bank and a 200' altitude loss.
- (e) In approach configuration, coupled or uncoupled, a malfunction with a 1 second delay in recovery initiation may result in a 15° bank and a 20' altitude loss.

SECTION 4 - NORMAL PROCEDURES

AUTOFLITE II PREFLIGHT INSPECTION

- (a) AutoFlite master switch - ON.
- (b) Rotate Turn Command Knob to left and right. Aircraft control wheels should rotate in corresponding directions.
- (c) With AutoFlite II on, rotate aircraft control wheel to left and right. Only light forces should be required to override roll servo clutch.
- (d) AutoFlite II master switch - OFF - rotate control wheel left and right to assure disengagement.

AUTOFLITE II IN-FLIGHT PROCEDURE

- (a) Engagement
 - (1) Check Turn Command Knob in center detent position.
 - (2) AutoFlite II master switch - ON.
- (b) Disengagement
 - (1) AutoFlite II master switch - OFF.
- (c) Heading Changes
 - (1) Move Trim Knob on instrument for Drift Correction from a Constant Heading.
 - (2) Move Turn Command Knob for left or right banked turns. Rotation of knob to stop will yield an appropriate bank angle to obtain an appropriate standard rate turn. Intermediate settings may be used for lesser turn rates.
- (d) OMNI Tracker
 - (1) Turn Command Knob - move to center detent position and push IN to engage tracker. Aircraft will track desired radial established on NAV 1 (or as selected, if equipped with a NAV Selector Switch).

Tracker must be engaged within 10° of being "on course," i.e. VOR course needle centered and aircraft heading within a 10° of VOR course.
 - (2) Trim Knob - push IN for high sensitivity. Use high sensitivity position for Localizer tracking and as desired for OMNI tracking.
- (e) Maintain directional trim during all autopilot operations.

SECTION 5 - PERFORMANCE

No changes to the basic performance provided by Section 5 of this Pilot's Operating Handbook are necessary for this supplement.

SUPPLEMENT 3

AUTOCONTROL IIIB AUTOPILOT INSTALLATION

SECTION 1 - GENERAL

This supplement supplies information necessary for the operation of the airplane when the optional Piper AutoControl IIIB Autopilot is installed. The information contained within this supplement is to be used "as described" in conjunction with the complete handbook.

This supplement has been "FAA Approved" as a permanent part of this handbook and must remain in this handbook at all times when the optional Piper AutoControl IIIB Autopilot is installed.

SECTION 2 - LIMITATIONS

- (a) Autopilot operation prohibited above 200 MPH CAS. (Autopilot Vmo)
- (b) Autopilot must be "OFF" for takeoff and landing.

SECTION 3 - EMERGENCY PROCEDURES

- (a) In an emergency the AutoControl IIIB can be disconnected by:
 - (1) Pushing the roll ON-OFF Rocker Switch "OFF."
 - (2) Pulling the Autopilot Circuit Breaker.
- (b) The autopilot can be overpowered at either control wheel.
- (c) An autopilot runaway, with a 3 second delay in the initiation of recovery while operating in climb, cruise or descending flight, could result in a 50° bank and 200' altitude loss.
- (d) An autopilot runaway, with a 1 second delay in the initiation of recovery, during an approach operation, coupled or uncoupled, could result in a 15° bank and 20' altitude loss.

SECTION 4 - NORMAL PROCEDURES

PREFLIGHT INSPECTION

- (a) AUTOPILOT
 - (1) Place Radio Coupler in "HDG" Mode (if installed) and place the AP "ON-OFF" switch to the "ON" position to engage roll section. Rotate roll command knob left and right and observe that control wheel describes a corresponding left and right turn, then center knob.
 - (2) Set proper D.G. heading on D.G. and turn HDG bug to aircraft heading. Engage "HDG" mode rocker switch and rotate HGD bug right and left. Aircraft control wheel should turn same direction as bug. Grasp control wheel and manually override servo, both directions.

(b) RADIO COUPLER -(OPTIONAL)

- (1) Tune and identify VOR or VOT station. Position Radio Coupler to OMNI Mode. Engage Autopilot "ON" and HDG switches. Set HDG bug to aircraft heading and rotate O.B.S. to cause OMNI indicator needle to swing left and right slowly. Observe that control wheel rotates in direction of needle movement.
- (2) Disengage AP "ON-OFF" switch. Reset Radio Coupler control to HDG.

IN-FLIGHT

- (a) Trim airplane (ball centered).

- (b) Check air pressure vacuum to ascertain that the directional gyro and attitude gyro are receiving sufficient air.

(c) Roll Section:

- (1) To engage, center Roll knob, push AP "ON-OFF" switch to "ON" position. To turn, rotate console ROLL knob in desired direction. (Maximum angle of bank should not exceed 30°.)
- (2) For heading mode, set directional gyro with magnetic compass. Push directional gyro HDG knob in, rotate bug to aircraft heading. Push console heading rocker (HDG) switch to "ON" position. To select a new aircraft heading, push D.G. heading knob "IN" and rotate, in desired direction of turn, to the desired heading.

(d) Radio Coupling VOR-ILS with H.S.I. Type Instrument Display. (Optional)

(1) VOR Navigation

- a. Tune and identify VOR Station. Select desired course with O.B.S. (H.S.I. Course Knob).
- b. Select OMNI mode on Radio Coupler.
- c. Select HDG mode on autopilot console to engage coupler. Aircraft will turn to a 45° intercept angle to intercept the selected VOR course. Intercept angle magnitude depends on radio needle off course magnitude, 100% needle deflection will result in 45° intercept with the intercept angle diminishing as the needle off set diminishes.
- d. NAV mode - NAV mode provides reduced VOR sensitivity for tracking weak, or noisy VOR signals. NAV mode should be selected after the aircraft is established on course.

(2) ILS-LOC Front Course

- a. Set inbound, front, localizer course on O.B.S. (H.S.I. Course Knob).
- b. Select LOC-Normal non-Radio Coupler to intercept and track inbound on the localizer. Select LOC-REV to intercept and track outbound to the procedure turn area.
- c. Select HDG Mode on autopilot console to engage coupler.

(3) ILS - Back Course

- a. Set inbound, front localizer course on O.B.S. (H.S.I. Course Knob).
- b. Select LOC-REV on radio coupler to intercept and track inbound on the back localizer course. Select LOC-NORM to intercept and track outbound on the back course to the procedure turn area.
- c. Select HDG mode on autopilot console to engage coupler.

(e) Radio Coupling – VOR/ILS with Standard directional gyro. (Optional)

Radio Coupler operation in conjunction with a standard directional gyro and VOR/LOC display differs from operation with an integrated display (H.S.I.) only in one respect. The HDG bug is used as the radio course datum and therefore must be set to match the desired VOR course as selected on the O.B.S.

(1) For VOR Intercepts and Tracking:

Select the desired VOR course and set the HDG bug to the same heading. Select OMNI mode on the coupler and HDG Mode on the autopilot console.

(2) For ILS Front Course Intercepts and Tracking:

Tune the localizer frequency and place the HDG bug on the inbound, front course heading. Select LOC-NORM mode on the coupler and HDG mode on the autopilot console.

(3) For LOC Back Course Intercepts and Tracking:

Tune the localizer frequency and place the HDG bug on the inbound course heading to the airport. Select LOC-REV mode with coupler and HDG mode on the autopilot console.

SECTION 5 - PERFORMANCE

No changes to the basic performance provided by Section 5 of the Pilot's Operating Handbook are necessary for this supplement.

THIS PAGE INTENTIONALLY LEFT BLANK

SUPPLEMENT 4

ALTIMATIC IIC AUTOPILOT INSTALLATION

SECTION 1 - GENERAL

This supplement supplies information necessary for the operation of the airplane when the optional AltiMatic IIC Autopilot is installed. The information contained within this supplement is to be used "as described" in conjunction with the complete handbook.

This supplement has been "FAA Approved" as a permanent part of this handbook and must remain in this handbook at all times when the optional AltiMatic IIC Autopilot is installed.

SECTION 2 - LIMITATIONS

- (a) Autopilot operation prohibited above 174 KIAS. (Autopilot Vmo).
- (b) Autopilot must be "OFF" during takeoff and landing.
- (c) Required placard P/N 13A660-1 "Conduct Trim Check prior to flight (see P/O/H)" to be installed in clear view of pilot.

SECTION 3 - EMERGENCY PROCEDURES

This aircraft is equipped with a Master Disconnect/Interrupt Switch on the pilot's control wheel. When the switch button is depressed it will disconnect the autopilot. When depressed and held it will interrupt all Electric Elevator Trim Operations. Trim operations will be restored when the switch is released. If an autopilot or trim emergency is encountered, do not attempt to determine which system is at fault. Immediately depress and hold the Master Disconnect/Interrupt button. Turn off autopilot and trim master switch and retrim aircraft, then release the interrupt switch.

NOTE

During examination of this supplement, the pilot is advised to locate and identify the autopilot controls, the trim master switch and circuit breakers for both systems.

- (a) In the event of an autopilot malfunction the autopilot can be:
 - (1) Overpowered at either control wheel.

CAUTION

Do not overpower autopilot pitch axis for periods longer than 3 seconds because the autotrim system will operate in a direction to oppose the pilot and will, thereby, cause an increase in the pitch overpower forces.

- (2) Disconnected by depressing the Master Disconnect/Interrupt Switch.
 - (3) Disconnected by depressing the Trim Switch "AP OFF" bar.
 - (4) Disconnected by pushing the roll rocker switch "OFF."
- (b) In the event of a trim malfunction:
- (1) Depress and hold the Master Trim Interrupt Switch.
 - (2) Trim Master Switch - "OFF." Retrim aircraft as necessary using manual trim system.
 - (3) Release Master Interrupt Switch - be alert for possible trim action.
 - (4) Trim Circuit Breaker - Pull. Do not operate trim until problem is corrected.
 - (5) If the trim system operates only in one direction, pull the circuit breaker and do not operate the trim system until corrective action is taken. Monitor autopilot operation closely when operating without trim follow-up.
- (c) If a trim runaway occurs with the autopilot operating, the above procedure will disconnect the autopilot which will immediately result in higher control wheel forces. Be prepared to manually retrim, as necessary to eliminate undesirable forces.
- (d) Altitude Loss During Malfunction:
- (1) An autopilot malfunction during climb, cruise or descent with a 3 second delay in recovery initiation could result in as much as 50° of bank and 320' of altitude loss.
 - (2) An autopilot malfunction during an approach with a 1 second delay in recovery initiation could result in as much as 20° of bank and 60' altitude loss. Maximum altitude loss measured in approach configuration and operating either coupled or uncoupled.

EMERGENCY OPERATION WITH OPTIONAL NSD 360A (HSI)
(Slaved and/or Non-Slaved)

- (a) Appearance of HDG Flag:
- (1) Check air supply gauge (vac or pressure) for adequate air supply (4 in. Hg min.).
 - (2) Check NSD 360A circuit breaker.
 - (3) Observe display for proper operation.
- (b) To disable heading card - pull circuit breaker and use magnetic compass for directional data. (Factory installations may utilize a combined NSD and electric trim circuit breaker.)

NOTE

If heading card is not operational, autopilot should not be used.

- (c) With card disabled - VOR/Localizer and Glide Slope displays are still functional: use card set to rotate card to aircraft heading for correct picture.
- (d) Slaving Failure - (i.e. failure to self correct for gyro drift):
- (1) Check gyro slaving switch is set to No. 1 position (if equipped with Slave No. 1 - No. 2 switch) or "Slaved" position when equipped with Slaved and Free Gyro Mode Switch.
 - (2) Check for HDG Flag.
 - (3) Check NSD 360A circuit breaker.
 - (4) Reset heading card while observing slaving meter.

NOTE

Dead slaving meter needle or a needle displaced fully one direction indicates a slaving system failure.

- (5) Select slaving amplifier No. 2, if equipped. If not equipped, proceed with No. 7 below.
- (6) Reset heading card while checking slaving meter. If proper slaving indication is not obtained,
- (7) Switch to free gyro mode and periodically set card as an unslaved gyro.

NOTE

In the localizer mode, the "TO-FROM" arrows may remain out of view, depending upon the design of the NAV converter used in the installation.

SECTION 4 - NORMAL PROCEDURES

PREFLIGHT INSPECTION - AUTOPILOT

- (a) Roll Section
 - (1) Place Radio Coupler in "Heading" mode and place roll rocker switch "ON" to engage roll section. Rotate roll command knob left and right and observe that control wheel describes a corresponding left and right turn, then center knob.
 - (2) Set proper D.G. Heading on D.G. and turn Heading Bug to aircraft heading. Engage "Heading" mode rocker switch and rotate heading bug right and left. Aircraft control wheel should turn same direction as bug. Grasp control wheel and manually override servo, both directions.
 - (3) Disengage autopilot by depressing trim switch. Check aileron operation is free and autopilot is disconnected from controls.
- (b) Pitch Section
 - (1) Engage "Roll" rocker switch.
 - (2) Center pitch command disc and engage "Pitch" rocker switch.
 - (3) Rotate pitch command disc up and then down and check control yoke moves same direction. Check to see that servo can be overridden by hand at control wheel.

NOTE

Autopilot might not be able to raise elevators, on ground, without assistance from pilot.

- (4) Hold control yoke and disengage autopilot by pressing Master Autopilot Disconnect/Trim Interrupt Switch button. Check Roll and Pitch controls to assure autopilot has disconnected.

Trim System

General

This aircraft is equipped with a Command Trim System designed to withstand any type of single malfunction, either mechanical or electrical, without uncontrolled operation resulting. The preflight check procedure is designed to uncover hidden failures that might otherwise go undetected. Proper operation of the electric elevator trim system is predicated on conducting the following preflight check before each flight. If the trim system fails any portion of the procedure, pull the trim circuit breaker out until trim system is repaired. Substitution of any trim system component for another model is not authorized. For emergency interrupt information, refer to Section 3 of this Supplement.

Command Electric Trim Switch

The Command Electric Trim Switch on the left hand portion of the pilot's control wheel has two functions:

- (1) When the top bar (AP OFF) is pressed, it disconnects the Autopilot.
- (2) When the top bar is pressed AND the rocker is moved forward, nose down trim will occur, when moved aft, nose up trim will occur.

(c) Pre-Flight: Command Trim - Before Each Flight

- (1) Check trim circuit breaker - IN.
- (2) Trim Master Switch - ON.
- (3) AP OFF - Check normal trim operation - UP. Grasp trim wheel and check override capability. Check nose down operation. Recheck override.
- (4) With trim operating - depress interrupt switch - trim should stop - release interrupt switch - trim should operate.
- (5) Activate center bar only - Push rocker fore and aft - only. Trim should not operate with either separate action.

(d) Autotrim - Before Each Flight

- (1) AP ON - (Roll and Pitch Sections) Check automatic operation by activating autopilot pitch command UP then DN. Observe trim operation follows pitch command direction.

NOTE

In autopilot mode, there will be approximately a 3 second delay between operation of pitch command and operation of trim.

- (2) Press center bar (AP OFF) - release - check autopilot disengagement.
- (3) Rotate trim wheel to check manual trim operation. Reset to takeoff position prior to takeoff.

AUTOPILOT IN-FLIGHT PROCEDURE

- (a) Trim airplane (Ball Centered).
- (b) Check air pressure or vacuum to ascertain that the directional gyro and attitude gyro are receiving sufficient air.
- (c) Roll Section
 - (1) To engage. Center ROLL knob, push ROLL rocker to "ON" position. To turn, rotate console ROLL knob in desired direction.
 - (2) For heading mode, set directional gyro with magnetic compass. Push directional gyro HDG knob in, rotate to select desired heading. Push console heading rocker (HDG) to "ON" position. (Maximum angle to bank will be 20° with heading lock engaged.)
- (d) Pitch Section (Roll section must be engaged prior to pitch section engagement).
 - (1) Center pitch trim indicator with the pitch command disc.
 - (2) Engage pitch rocker switch. To change attitude, rotate pitch command disc in the desired direction.

(e) Altitude Hold

Upon reaching desired or cruising altitude, engage altitude hold mode rocker switch. As long as Altitude Hold mode rocker is engaged, aircraft will maintain selected altitude. For maximum passenger comfort, rate of climb or descent should be reduced to approximately 500 FPM prior to altitude hold engagement. For accurate Altitude Holding below 90 KIAS lower flaps one or two notches.

NOTE

Prior to disengaging Altitude Hold mode, rotate Pitch Command to center.

(f) Radio Coupling VOR-ILS with H.S.I. type instrument display. (Optional)

(1) VOR Navigation

- a. Tune and identify VOR Station. Select desired course by rotating CRS knob of H.S.I.
- b. Select OMNI mode on Radio Coupler.
- c. Select HDG mode on autopilot console to engage coupler. Aircraft will turn to a 45° intercept angle to intercept the selected VOR course. Intercept angle magnitude depends on radio needle off - course magnitude, 100% needle deflection will result in 45° intercept angle, diminishing as the needle off-set diminishes.
- d. NAV mode - NAV mode provides reduced VOR sensitivity for tracking weak, or noisy, VOR signals. NAV mode should be selected after the aircraft is established on course.

(2) ILS-LOC Front Course

- a. Set inbound, front, localizer course on H.S.I.
- b. Select LOC-Normal on Radio Coupler to intercept and track inbound on the localizer. Select LOC-REV to intercept and track the localizer course outbound to procedure turn area.
- c. Engage HDG mode on autopilot console to engage coupler.

(3) ILS - Back Course

- a. Set inbound, front, localizer course on H.S.I.
- b. Select LOC-REV, on radio coupler to intercept and track inbound on the back localizer course. Select LOC-NORM to intercept and track outbound on the back course to the procedure turn area.
- c. Engage HDG mode on autopilot console to engage coupler.

(g) Radio Coupling - VOR/ILS with standard directional gyro. (Optional)

Radio Coupler operation in conjunction with a standard directional gyro and VOR/LOC display differs from operation with an integrated display (H.S.I.) only in one respect. The HDG bug is used as the radio course datum and therefore must be set to match the desired VOR/ILS course as selected on the O.B.S.

(1) For VOR Intercepts and Tracking:

Select the desired VOR Course and set the HDG bug to the same heading. Select OMNI mode on the coupler and engage HDG mode on the autopilot console.

(2) For ILS Front Course Intercepts and Tracking:

Tune the localizer frequency and place the HDG bug on the inbound, front course heading. Select LOC-NORM mode on the coupler and engage HDG mode on the autopilot console.

(3) For LOC Back Course Intercepts and Tracking:

Tune the localizer frequency and place the HDG bug on the inbound course heading to the airport. Select LOC-REV mode on the coupler and engage HDG mode on the autopilot console.

(h) Coupled Approach Operations

(1) VOR or LOC

- a. After arrival at the VOR Station, track outbound to the procedure turn area as described in Section 4 (f) or (g) as appropriate. Slow to 90-95 KIAS, while inbound to F.A.F. and lower one or two notches of flaps (10° or 25°).
- b. Use HDG mode and Pitch or Altitude Hold modes as appropriate during procedure turn.
- c. At the F.A.F. inbound, return to pitch mode for control of descent and lower landing gear.
- d. At the M.D.A. Select Altitude Hold mode and add power for level flight. Monitor altimeter to assure accurate altitude control is being provided by the autopilot.
- e. Go Around. For missed approach select desired pitch attitude with pitch command disc and disengage altitude hold mode. This will initiate the pitch up attitude change. Immediately add takeoff power and monitor Altimeter and rate of climb for positive climb indication. After climb is established, retract flaps and gear. Adjust attitude as necessary for desired airspeed and select HDG mode for turn from the VOR final approach course.

(2) ILS - Front Course Approach With Glide Slope Capture. (Optional)

- a. Track inbound to L.O.M as described in Section 4 (f) or (g) above and in Altitude Hold mode.
- b. Inbound to L.O.M. slow to 90-95 KIAS and lower flaps one or two notches (10° or 25°).
- c. Automatic Glide Slope capture will occur at Glide Slope intercept if the following conditions are met:
 1. Coupler in LOC-Normal mode.
 2. Altitude Hold mode engaged (Altitude Rocker on Console).
 3. Under Glide Slope for more than 20 seconds.
 4. Localizer radio frequency selected on NAV Receiver.
- d. At Glide Slope Intercept immediately lower landing gear and reduce power to maintain 90-95 KIAS on final approach. Glide Slope capture is indicated by lighting of the green Glide Slope engage Annunciator Lamp and by a slight pitch down of the aircraft.
- e. Monitor localizer and Glide Slope raw data throughout approach. Adjust power as necessary to maintain correct final approach airspeed. All power changes should be of small magnitude and smoothly applied for best tracking performance. Do not change aircraft configuration during approach while autopilot is engaged.
- f. Conduct missed approach maneuver as described in (h) (1) e. above.

NOTE

Glide Slope Coupler will not automatically decouple from Glide Slope. Decoupling may be accomplished by any of the following means:

1. Disengage Altitude Mode.
2. Switch Radio Coupler to HDG Mode.
3. Disengage Autopilot.

SECTION 5 - PERFORMANCE

No changes to the basic performance provided by Section 5 of the Pilot's Operating Handbook are necessary for this supplement.

SUPPLEMENT 5

PIPER ELECTRIC PITCH TRIM

SECTION 1 - GENERAL

This supplement supplies information necessary for the operation of the airplane when the optional Piper Electric Pitch Trim is installed. The information contained within this supplement is to be used "as described" in conjunction with the complete handbook.

This supplement has been "FAA Approved" as a permanent part of this handbook and must remain in this handbook at all times when the optional Piper Electric Pitch Trim is installed.

SECTION 2 - LIMITATIONS

A Placard stating "Conduct trim check prior to flight - See POH" to be installed in clear view of the pilot.

SECTION 3 - EMERGENCY PROCEDURES

- (a) Overpower control wheel forces initially, and depress and hold the master interrupt switch on the control wheel. This will stop all trim action.
- (b) Retrim aircraft with manual trim system to alleviate control force.
- (c) Move the trim master switch to the OFF position.
- (d) Release interrupt switch while observing trim wheel to assure that the trim system is disabled.
- (e) Pull trim circuit breaker. Leave circuit breaker open until the trim system is corrected.

SECTION 4 - NORMAL PROCEDURES

(a) **PRE-FLIGHT INSPECTION - BEFORE EACH FLIGHT**

- (1) Circuit breaker - IN.
- (2) Trim Master Switch - ON.
- (3) Depress switch center bar and rock switch fore (down) and aft (up) - check trim operates in correct direction both Up and Down.
- (4) Release trim switch. Depress only the center bar - Trim should not operate.
- (5) Rock switch fore and aft only - (Do not depress center bar) Trim should not operate.
- (6) Operate trim normally - grasp trim wheel and check that trim may be overpowered by hand.
- (7) Operate trim Up or Down - Depress Interrupt Switch - check that trim action stops.

If the trim system fails any portion of the above check procedures, turn the trim master switch OFF and do not operate the trim system until the system is corrected. This trim system has been designed to require two separate failures before uncontrolled operation can occur. The pre-flight inspection procedure is established to identify a system failure that might otherwise go undetected.

(b) IN-FLIGHT PROCEDURES

Depress center bar and move switch rocker fore or aft to obtain electric trim nose down or up.
Release switch to stop trimming.

SECTION 5 - PERFORMANCE

No changes to the basic performance provided by Section 5 of this Pilot's Operating Handbook are necessary for this supplement.

TABLE OF CONTENTS

SECTION 10

OPERATING TIPS

Paragraph No.		Page No.
10.1	General	10-1
10.3	Operating Tips	10-1

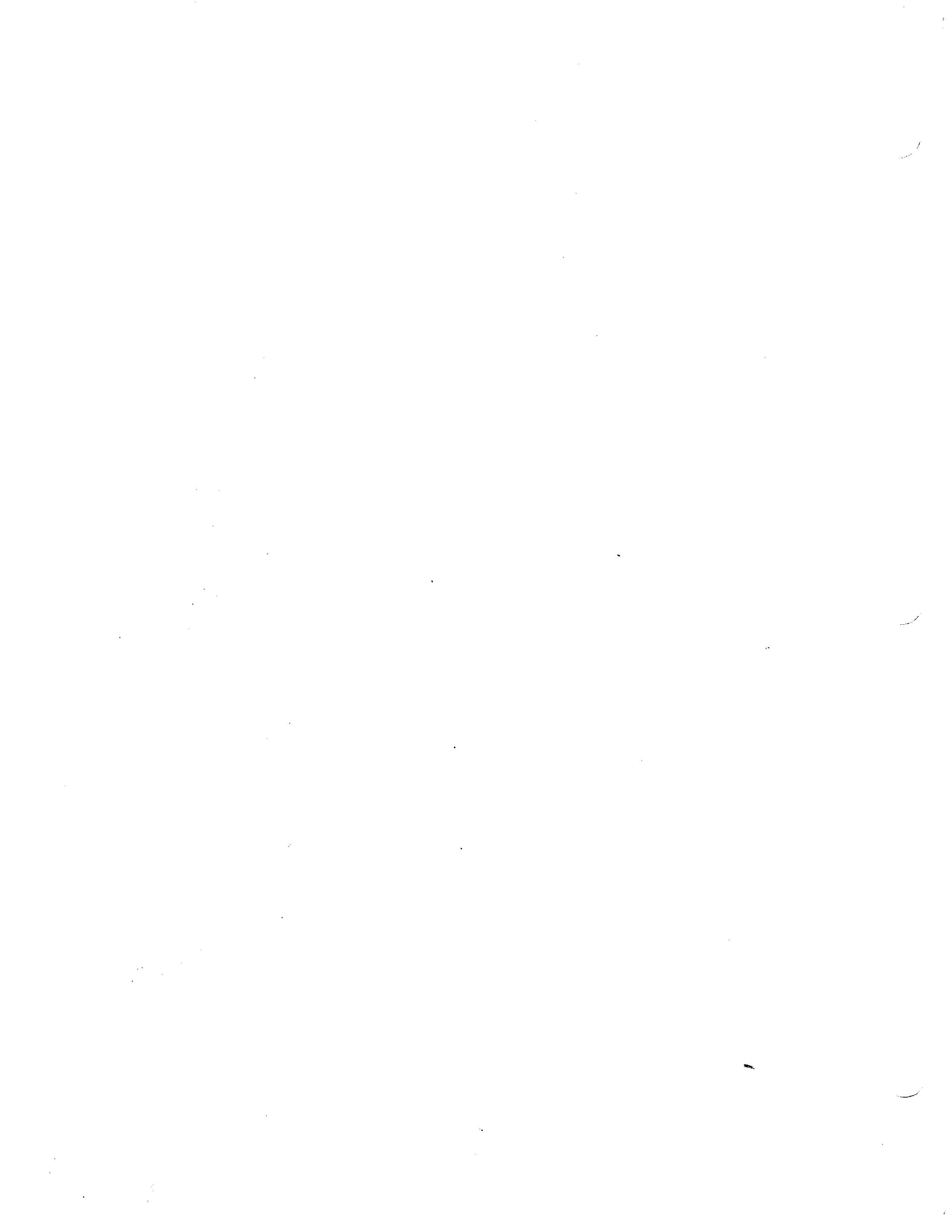

SECTION 10
OPERATING TIPS

10.1 GENERAL

This section provides operating tips of particular value in the operation of the Cherokee Lance.

10.3 OPERATING TIPS

- (a) Learn to trim for takeoff so that only a very light back pressure on the control wheel is required to lift the airplane off the ground.
- (b) The best speed for takeoff is about 70 MPH IAS (61 KTS IAS) under normal conditions. Trying to pull the airplane off the ground at too low an airspeed decreases the controllability of the airplane in the event of engine failure.
- (c) Flaps may be lowered at airspeeds up to 125 MPH CAS (109 KTS CAS). To reduce flap operating loads, it is desirable to have the airplane at a slower speed before extending the flaps.
- (d) Before attempting to reset any circuit breaker, allow a two to five minute cooling off period.
- (e) Before starting the engine, check that all radio switches, light switches and the pitot heat switch are in the off position so as not to create an overloaded condition when the starter is engaged.
- (f) Strobe lights should not be operating when flying through overcast and clouds, since reflected light can produce spacial disorientation. Do not operate strobe lights when taxiing in the vicinity of other aircraft.
- (g) The rudder pedals are suspended from a torque tube which extends across the fuselage. The pilot should become familiar with the proper positioning of his feet on the rudder pedals so as to avoid interference with the torque tube when moving the rudder pedals or operating the toe brakes.
- (h) In an effort to avoid accidents, pilots should obtain and study the safety related information made available in FAA publications such as regulations, advisory circulars, Aviation News, AIM and safety aids.
- (i) The shape of the wing fuel tanks is such that in certain maneuvers the fuel may move away from the tank outlet. If the outlet is uncovered, the fuel flow will be interrupted and a temporary loss of power may result. Pilots can prevent inadvertent uncovering of the outlet by avoiding maneuvers which could result in uncovering the outlet.

Extreme running turning takeoffs should be avoided as fuel flow interruption may occur.

Prolonged slips or skids which result in excess of 2000 ft. of altitude loss, or other radical or extreme maneuvers which could cause uncovering of the fuel outlet must be avoided as fuel flow interruption may occur when tank being used is not full.

THIS PAGE INTENTIONALLY LEFT BLANK